

LEGEND

- ← SURFACE DRAINAGE SWALE DIRECTION
- BUILDING SETBACK LINE
- W — WATER SERVICE (PROPOSED)
- SAN — SANITARY LATERAL (PROPOSED)
- — — 6' ELECTRIC AND GAS LINES BELOW GRADE EASEMENT
- 10' UTILITY EASEMENT
- ☼ STREET LIGHT



TRANSECT ZONE: T3
 LOT SQUARE FOOTAGE: 7,845
 BLDG. ENV. WIDTH AT SETBACK: 55.6'

NOTE:
 AREAS DELINEATED AS VISION TRIANGLE AREAS
 SHALL HAVE NO PLANTINGS OVER TWO (2) FEET
 IN HEIGHT.

TYPICAL VISION CORNER DETAIL

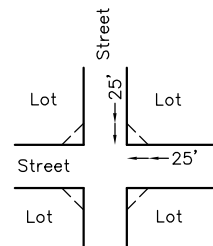

BSE1921\Final Plat\sales maps.dwg

LOT 1
 TERRAVESSA
 FITCHBURG LANDS, LLC

DATE: 08-05-2019 PROJECT NO.: BSE1921

SCALE
 1" = 40'

IF THIS BAR DOES NOT MEASURE 1"
 THEN DRAWING IS NOT TO SCALE

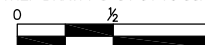

Burse
 surveying & engineering Inc.
 2801 International Lane, Suite 101
 Madison, WI 53704 608.250.9263
 Fax: 608.250.9266
 email: mburse@bse-inc.net
 www.bursesurveyengr.com

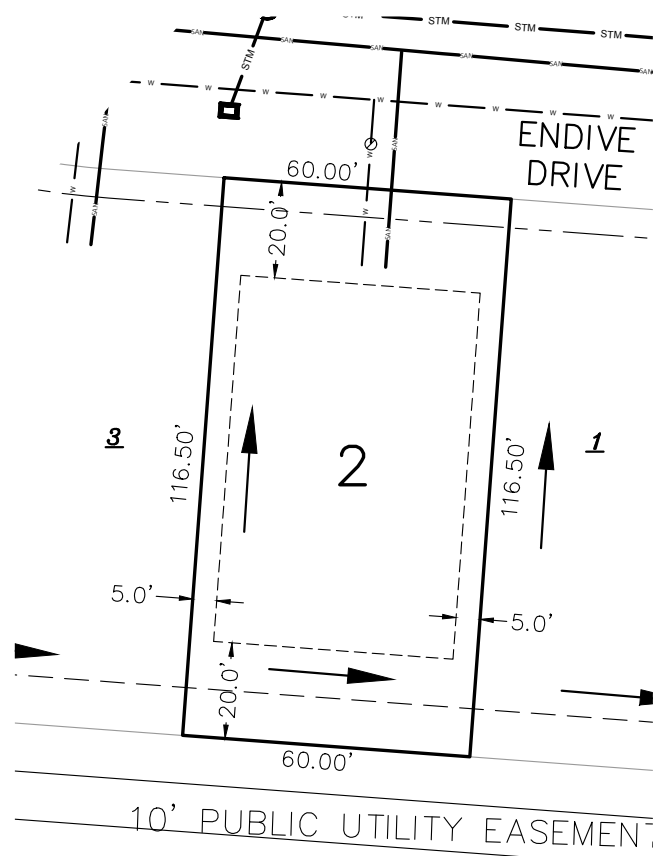

LEGEND

- SURFACE DRAINAGE SWALE DIRECTION
- BUILDING SETBACK LINE
- WATER SERVICE (PROPOSED)
- SANITARY LATERAL (PROPOSED)
- 6' ELECTRIC AND GAS LINES BELOW GRADE EASEMENT
- 10' UTILITY EASEMENT
- STREET LIGHT

TRANSECT ZONE: T3
 LOT SQUARE FOOTAGE: 6,990
 BLDG. ENV. WIDTH AT SETBACK: 50.0'

BSE1921\Final Plat\sales maps.dwg

LOT 2
 TERRAVESSA
 FITCHBURG LANDS, LLC

DATE 12-13-2018	PROJECT NO. BSE1921
SCALE 1" = 40'	
IF THIS BAR DOES NOT MEASURE 1" THEN DRAWING IS NOT TO SCALE	

Burse
 surveying & engineering LLC

2801 International Lane, Suite 101
 Madison, WI 53704 608.250.9263
 Fax: 608.250.9266
 email: mburse@bse-inc.net
 www.bursesurveyengr.com

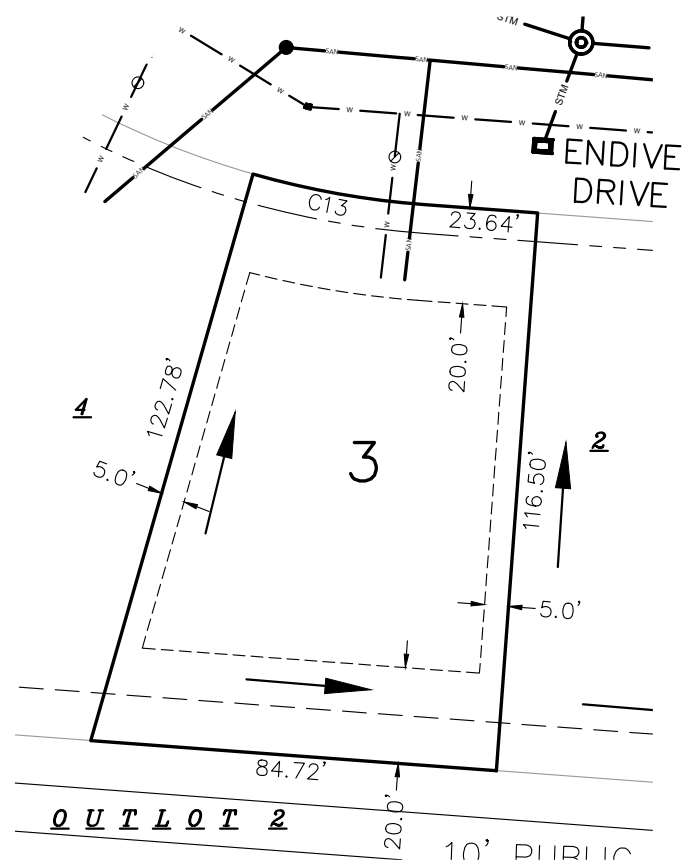

LEGEND

- SURFACE DRAINAGE SWALE DIRECTION
- BUILDING SETBACK LINE
- WATER SERVICE (PROPOSED)
- SANITARY LATERAL (PROPOSED)
- 6' ELECTRIC AND GAS LINES BELOW GRADE EASEMENT
- 10' UTILITY EASEMENT
- STREET LIGHT

TRANSECT ZONE: T3
 LOT SQUARE FOOTAGE: 8,506
 BLDG. ENV. WIDTH AT SETBACK: 54.0'

BSE1921\Final Plat\sales maps.dwg

LOT 3
 TERRAVESSA
 FITCHBURG LANDS, LLC

DATE 12-13-2018	PROJECT NO. BSE1921
SCALE 1" = 40'	
IF THIS BAR DOES NOT MEASURE 1" THEN DRAWING IS NOT TO SCALE	

Burse
 surveying & engineering LLC
 2801 International Lane, Suite 101
 Madison, WI 53704 608.250.9263
 Fax: 608.250.9266
 email: mburse@bse-inc.net
 www.bursesurveyengr.com

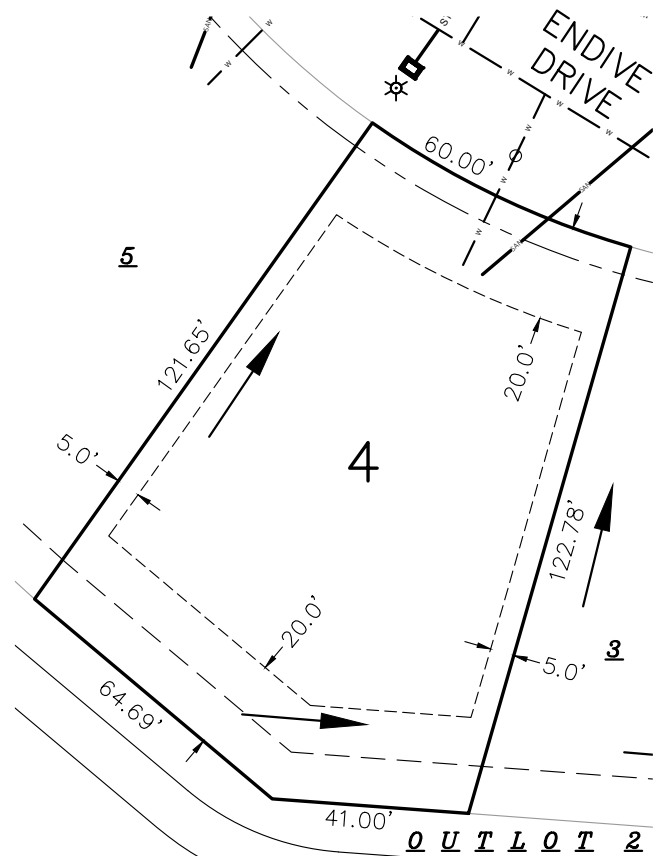

LEGEND

- SURFACE DRAINAGE SWALE DIRECTION
- BUILDING SETBACK LINE
- WATER SERVICE (PROPOSED)
- SANITARY LATERAL (PROPOSED)
- 6' ELECTRIC AND GAS LINES BELOW GRADE EASEMENT
- 10' UTILITY EASEMENT
- STREET LIGHT

TRANSECT ZONE: T3
 LOT SQUARE FOOTAGE: 10,346
 BLDG. ENV. WIDTH AT SETBACK: 55.0'

BSE1921\Final Plat\sales maps.dwg

LOT 4
 TERRAVESSA
 FITCHBURG LANDS, LLC

DATE 12-13-2018	PROJECT NO. BSE1921
SCALE 1" = 40'	
IF THIS BAR DOES NOT MEASURE 1" THEN DRAWING IS NOT TO SCALE	

Burse
 surveying & engineering LLC

2801 International Lane, Suite 101
 Madison, WI 53704 608.250.9263
 Fax: 608.250.9266
 email: mburse@bse-inc.net
 www.bursesurveyengr.com

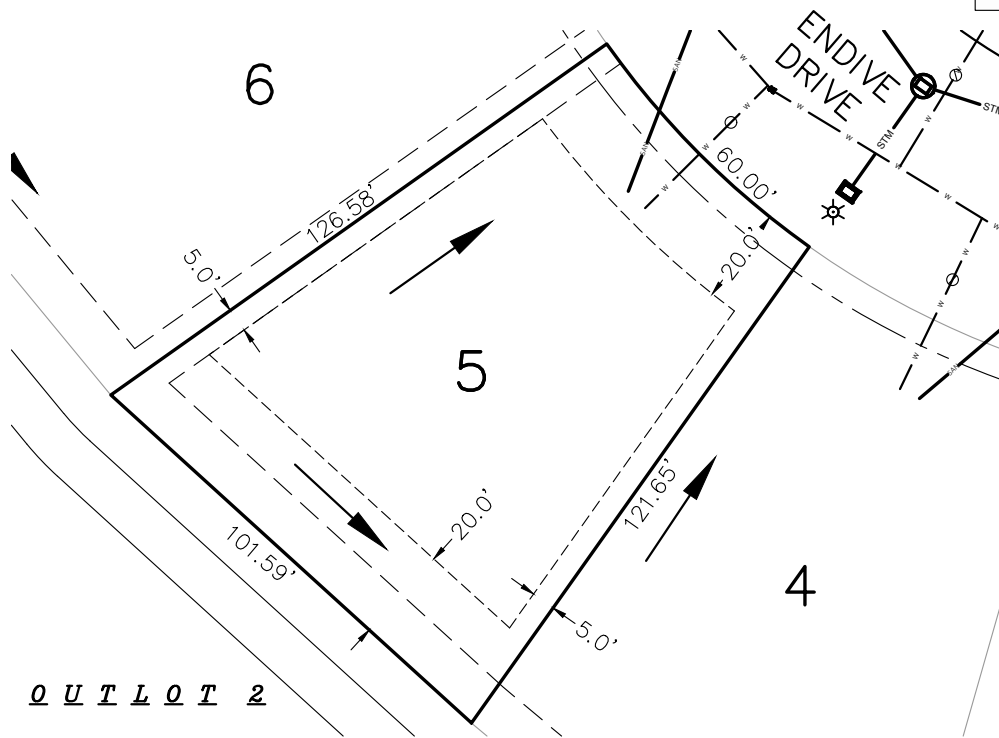

LEGEND

- SURFACE DRAINAGE SWALE DIRECTION
- BUILDING SETBACK LINE
- WATER SERVICE (PROPOSED)
- SANITARY LATERAL (PROPOSED)
- 6' ELECTRIC AND GAS LINES BELOW GRADE EASEMENT
- 10' UTILITY EASEMENT
- STREET LIGHT



TRANSECT ZONE: T3
 LOT SQUARE FOOTAGE: 9,758
 BLDG. ENV. WIDTH AT SETBACK: 50.0'

BSE1921\Final Plat\sales maps.dwg

LOT 5
 TERRAVESSA
 FITCHBURG LANDS, LLC

DATE 12-13-2018	PROJECT NO. BSE1921
SCALE 1"=40'	
IF THIS BAR DOES NOT MEASURE 1" THEN DRAWING IS NOT TO SCALE	

Burse
 surveying & engineering ^{LLC}
 2801 International Lane, Suite 101
 Madison, WI 53704 608.250.9263
 Fax: 608.250.9266
 email: mburse@bse-inc.net
 www.bursesurveyengr.com

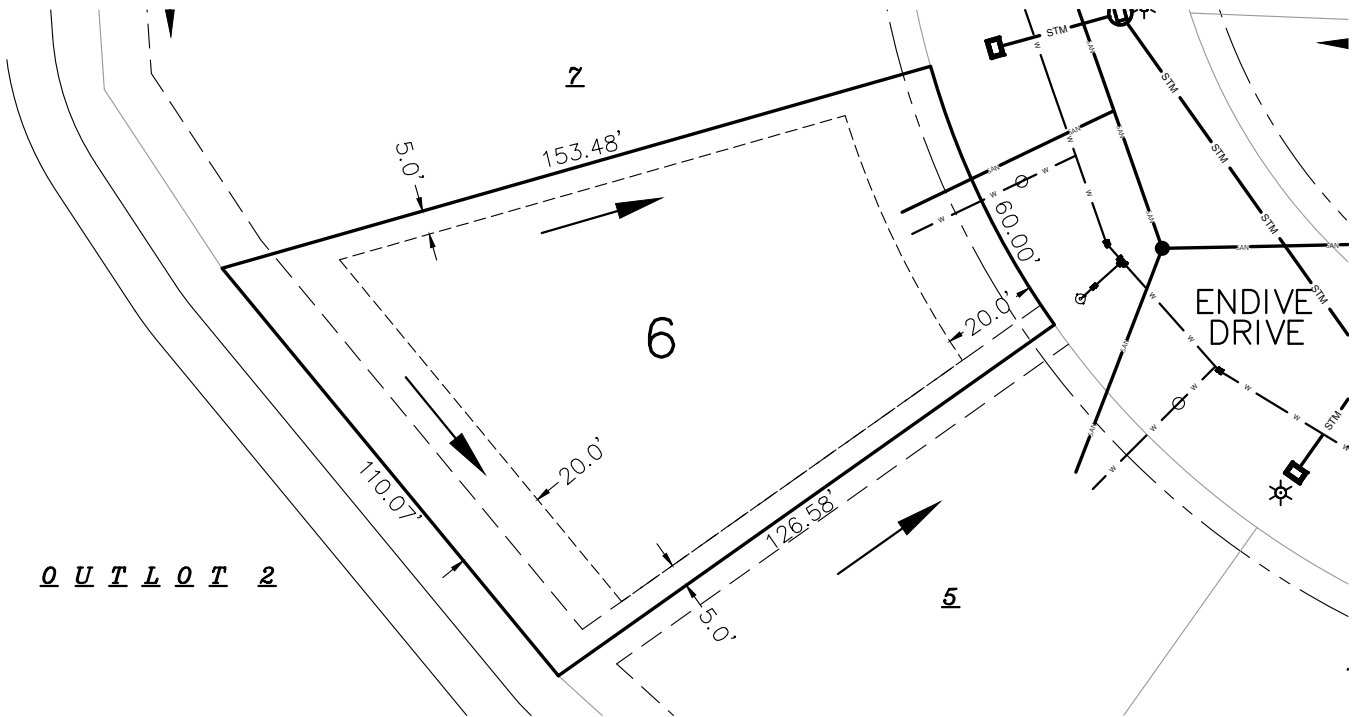

LEGEND

- SURFACE DRAINAGE SWALE DIRECTION
- BUILDING SETBACK LINE
- WATER SERVICE (PROPOSED)
- SANITARY LATERAL (PROPOSED)
- 6' ELECTRIC AND GAS LINES BELOW GRADE EASEMENT
- 10' UTILITY EASEMENT
- STREET LIGHT



TRANSECT ZONE: T3
 LOT SQUARE FOOTAGE: 11,363
 BLDG. ENV. WIDTH AT SETBACK: 50.0'

BSE1921\Final Plat\sales maps.dwg

LOT 6
 TERRAVESSA
 FITCHBURG LANDS, LLC

DATE 12-13-2018	PROJECT NO. BSE1921
SCALE 1" = 40'	
IF THIS BAR DOES NOT MEASURE 1" THEN DRAWING IS NOT TO SCALE	

Burse
 surveying & engineering LLC
 2801 International Lane, Suite 101
 Madison, WI 53704 G08.250.9263
 Fax: G08.250.9266
 email: mburse@bse-inc.net
 www.bursesurveyengr.com

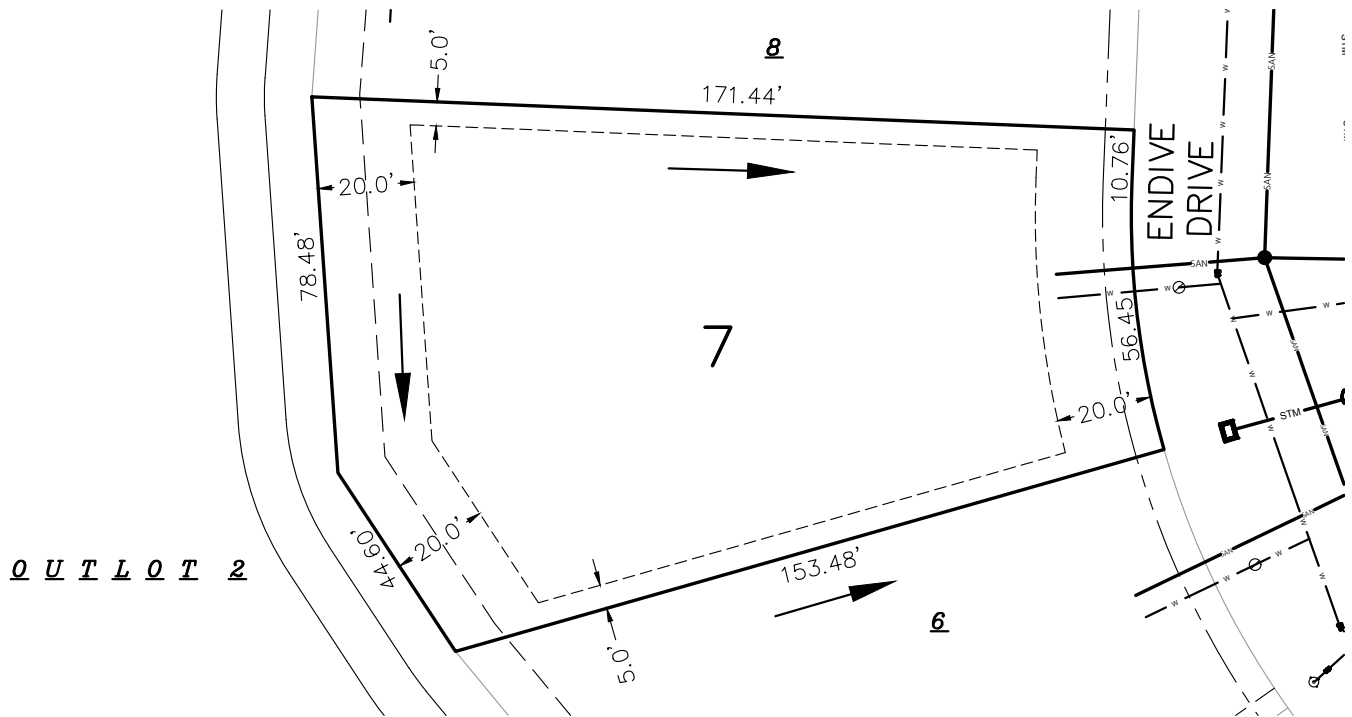

LEGEND

- SURFACE DRAINAGE SWALE DIRECTION
- BUILDING SETBACK LINE
- WATER SERVICE (PROPOSED)
- SANITARY LATERAL (PROPOSED)
- 6' ELECTRIC AND GAS LINES BELOW GRADE EASEMENT
- 10' UTILITY EASEMENT
- STREET LIGHT



TRANSECT ZONE: T3
 LOT SQUARE FOOTAGE: 15,564
 BLDG. ENV. WIDTH AT SETBACK: 63.3'

BSE1921\Final Plat\sales maps.dwg

LOT 7
 TERRAVESSA
 FITCHBURG LANDS, LLC

DATE 12-13-2018	PROJECT NO. BSE1921
SCALE 1" = 40'	
IF THIS BAR DOES NOT MEASURE 1" THEN DRAWING IS NOT TO SCALE	

Burse
 surveying & engineering LLC
 2801 International Lane, Suite 101
 Madison, WI 53704 608.250.9263
 Fax: 608.250.9266
 email: mburse@bse-inc.net
 www.bursesurveyengr.com

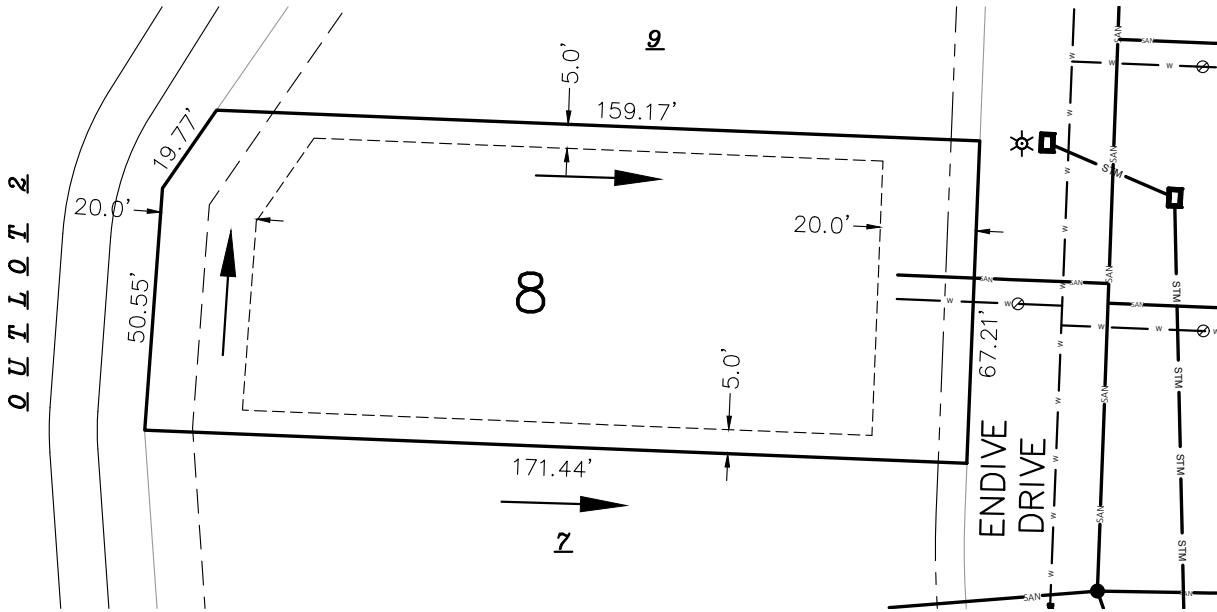

LEGEND

- SURFACE DRAINAGE SWALE DIRECTION
- BUILDING SETBACK LINE
- WATER SERVICE (PROPOSED)
- SANITARY LATERAL (PROPOSED)
- 6' ELECTRIC AND GAS LINES BELOW GRADE EASEMENT
- 10' UTILITY EASEMENT
- STREET LIGHT



TRANSECT ZONE: T3
 LOT SQUARE FOOTAGE: 11,364
 BLDG. ENV. WIDTH AT SETBACK: 57.2'

BSE1921\Final Plat\sales maps.dwg

LOT 8
 TERRAVESSA
 FITCHBURG LANDS, LLC

DATE 12-13-2018	PROJECT NO. BSE1921
SCALE 1" = 40'	
IF THIS BAR DOES NOT MEASURE 1" THEN DRAWING IS NOT TO SCALE	

Burse
 surveying & engineering INC.
 2801 International Lane, Suite 101
 Madison, WI 53704 608.250.9263
 Fax: 608.250.9266
 email: mburse@bse-inc.net
 www.bursesurveyengr.com

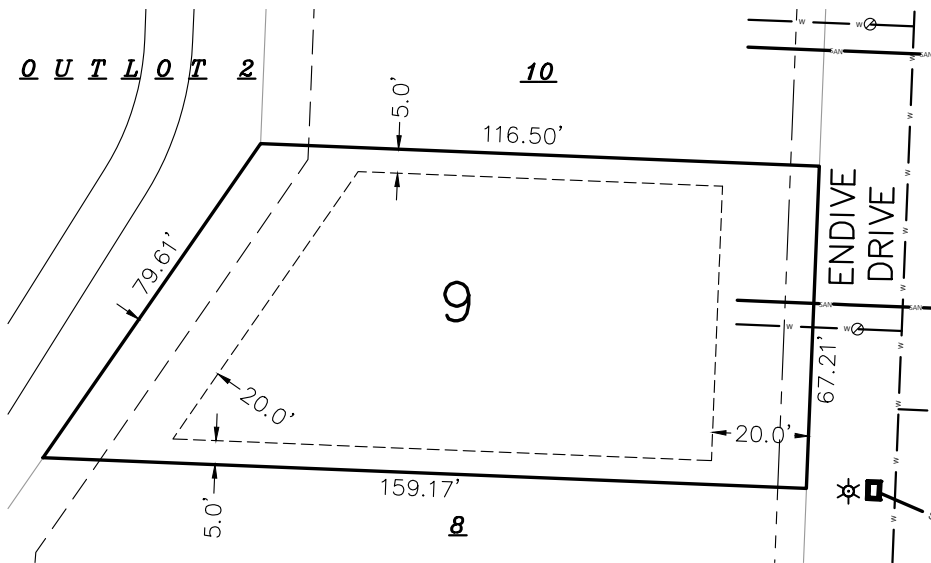

LEGEND

- SURFACE DRAINAGE SWALE DIRECTION
- BUILDING SETBACK LINE
- WATER SERVICE (PROPOSED)
- SANITARY LATERAL (PROPOSED)
- 6' ELECTRIC AND GAS LINES BELOW GRADE EASEMENT
- 10' UTILITY EASEMENT
- STREET LIGHT

TRANSECT ZONE: T3
 LOT SQUARE FOOTAGE: 9,264
 BLDG. ENV. WIDTH AT SETBACK: 57.2'

BSE1921\Final Plat\sales maps.dwg

LOT 9
 TERRAVESSA
 FITCHBURG LANDS, LLC

DATE 12-13-2018	PROJECT NO. BSE1921
SCALE 1" = 40'	
IF THIS BAR DOES NOT MEASURE 1" THEN DRAWING IS NOT TO SCALE	

Burse
 surveying & engineering LLC
 2801 International Lane, Suite 101
 Madison, WI 53704 G08.250.9263
 Fax: G08.250.9266
 email: mburse@bse-inc.net
 www.bursesurveyengr.com

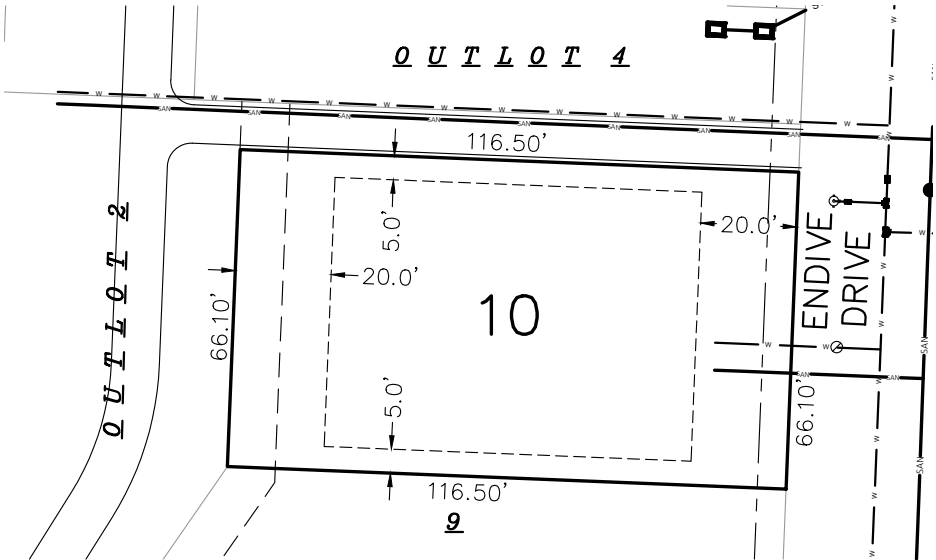

LEGEND

- SURFACE DRAINAGE SWALE DIRECTION
- BUILDING SETBACK LINE
- WATER SERVICE (PROPOSED)
- SANITARY LATERAL (PROPOSED)
- 6' ELECTRIC AND GAS LINES BELOW GRADE EASEMENT
- 10' UTILITY EASEMENT
- STREET LIGHT



TRANSECT ZONE: T3
 LOT SQUARE FOOTAGE: 7,701
 BLDG. ENV. WIDTH AT SETBACK: 56.1'

BSE1921\Final Plat\sales maps.dwg

LOT 10
 TERRAVESSA
 FITCHBURG LANDS, LLC

DATE 12-13-2018	PROJECT NO. BSE1921
SCALE 1" = 40'	
IF THIS BAR DOES NOT MEASURE 1" THEN DRAWING IS NOT TO SCALE	

Burse
 surveying & engineering LLC
 2801 International Lane, Suite 101
 Madison, WI 53704 608.250.9263
 Fax: 608.250.9266
 email: mburse@bse-inc.net
 www.bursesurveyengr.com

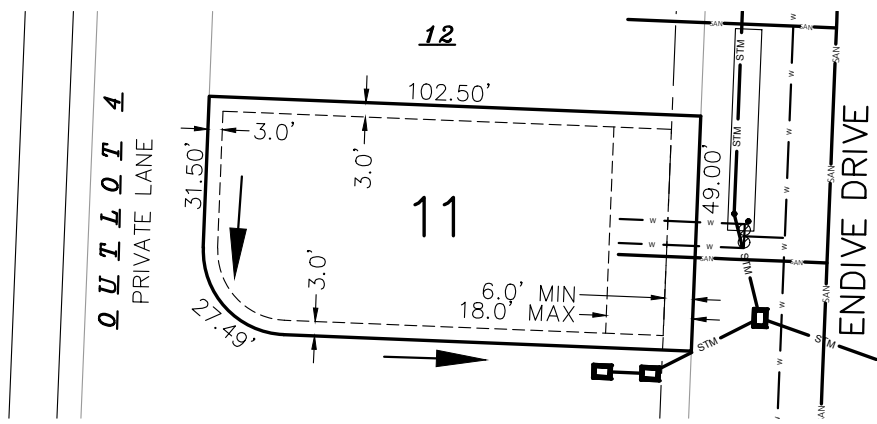

LEGEND

- SURFACE DRAINAGE SWALE DIRECTION
- BUILDING SETBACK LINE
- WATER SERVICE (PROPOSED)
- SANITARY LATERAL (PROPOSED)
- 6' ELECTRIC AND GAS LINES BELOW GRADE EASEMENT
- 10' UTILITY EASEMENT
- STREET LIGHT

TRANSECT ZONE: T4
 LOT SQUARE FOOTAGE: 4,957
 BLDG. ENV. WIDTH AT SETBACK: 43.0'

BSE1921\Final Plat\sales maps.dwg

LOT 11
 TERRAVESSA
 FITCHBURG LANDS, LLC

DATE 12-13-2018	PROJECT NO. BSE1921
SCALE 1" = 40'	
IF THIS BAR DOES NOT MEASURE 1" THEN DRAWING IS NOT TO SCALE	

Burse
 surveying & engineering LLC
 2801 International Lane, Suite 101
 Madison, WI 53704 608.250.9263
 Fax: 608.250.9266
 email: mburse@bse-inc.net
 www.bursesurveyengr.com

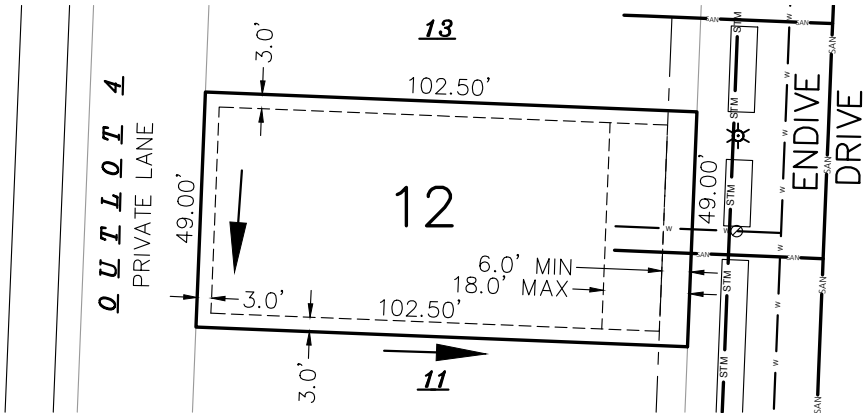

LEGEND

- SURFACE DRAINAGE SWALE DIRECTION
- BUILDING SETBACK LINE
- WATER SERVICE (PROPOSED)
- SANITARY LATERAL (PROPOSED)
- 6' ELECTRIC AND GAS LINES BELOW GRADE EASEMENT
- 10' UTILITY EASEMENT
- STREET LIGHT

TRANSECT ZONE: T4
 LOT SQUARE FOOTAGE: 5,023
 BLDG. ENV. WIDTH AT SETBACK: 43.0'

BSE1921\Final Plat\sales maps.dwg

LOT 12
 TERRAVESSA
 FITCHBURG LANDS, LLC

DATE 12-13-2018	PROJECT NO. BSE1921
SCALE 1" = 40'	
IF THIS BAR DOES NOT MEASURE 1" THEN DRAWING IS NOT TO SCALE	

Burse
 surveying & engineering LLC
 2801 International Lane, Suite 101
 Madison, WI 53704 608.250.9263
 Fax: 608.250.9266
 email: mburse@bse-inc.net
 www.bursesurveyengr.com

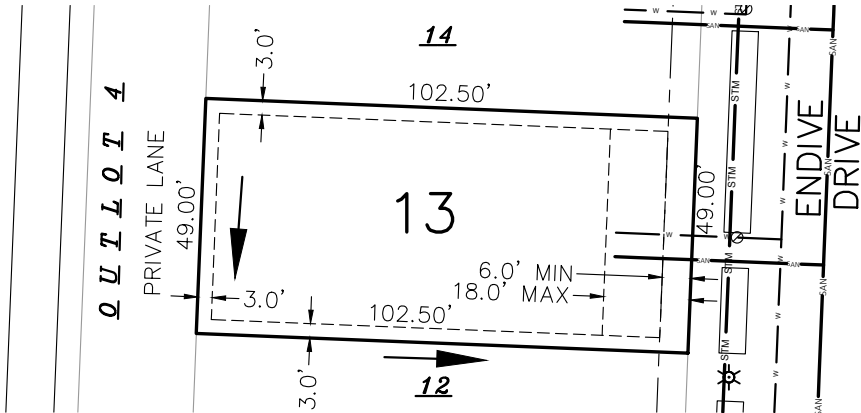

LEGEND

- SURFACE DRAINAGE SWALE DIRECTION
- BUILDING SETBACK LINE
- WATER SERVICE (PROPOSED)
- SANITARY LATERAL (PROPOSED)
- 6' ELECTRIC AND GAS LINES BELOW GRADE EASEMENT
- 10' UTILITY EASEMENT
- STREET LIGHT

TRANSECT ZONE: T4
 LOT SQUARE FOOTAGE: 5,023
 BLDG. ENV. WIDTH AT SETBACK: 43.0'

LOT 13
 TERRAVESSA
 FITCHBURG LANDS, LLC

DATE 12-13-2018	PROJECT NO. BSE1921
SCALE 1" = 40'	
IF THIS BAR DOES NOT MEASURE 1" THEN DRAWING IS NOT TO SCALE	

Burse
 surveying & engineering LLC
 2801 International Lane, Suite 101
 Madison, WI 53704 608.250.9263
 Fax: 608.250.9266
 email: mburse@bse-inc.net
 www.bursesurveyengr.com

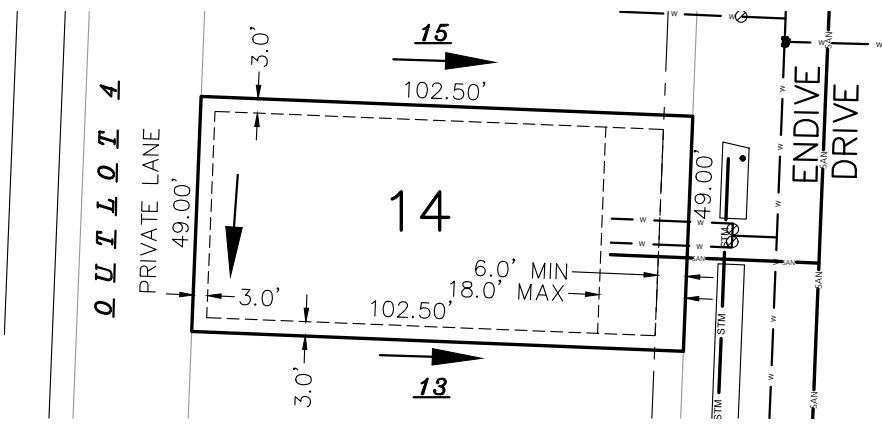

LEGEND

- SURFACE DRAINAGE SWALE DIRECTION
- BUILDING SETBACK LINE
- WATER SERVICE (PROPOSED)
- SANITARY LATERAL (PROPOSED)
- 6' ELECTRIC AND GAS LINES BELOW GRADE EASEMENT
- 10' UTILITY EASEMENT
- STREET LIGHT

TRANSECT ZONE: T4
 LOT SQUARE FOOTAGE: 5,023
 BLDG. ENV. WIDTH AT SETBACK: 43.0'

BSE1921\Final Plat\sales maps.dwg

LOT 14
 TERRAVESSA
 FITCHBURG LANDS, LLC

DATE 12-13-2018	PROJECT NO. BSE1921
SCALE 1" = 40'	
IF THIS BAR DOES NOT MEASURE 1" THEN DRAWING IS NOT TO SCALE	

Burse
 surveying & engineering LLC
 2801 International Lane, Suite 101
 Madison, WI 53704 608.250.9263
 Fax: 608.250.9266
 email: mburse@bse-inc.net
 www.bursesurveyengr.com

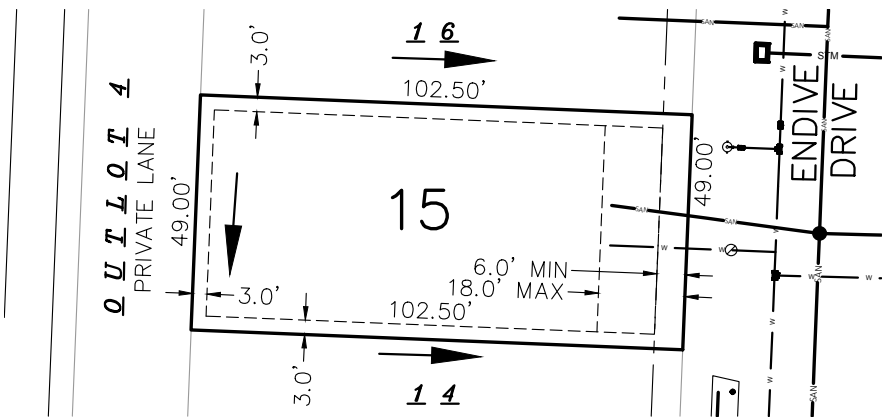

LEGEND

- SURFACE DRAINAGE SWALE DIRECTION
- BUILDING SETBACK LINE
- WATER SERVICE (PROPOSED)
- SANITARY LATERAL (PROPOSED)
- 6' ELECTRIC AND GAS LINES BELOW GRADE EASEMENT
- 10' UTILITY EASEMENT
- STREET LIGHT

TRANSECT ZONE: T4
 LOT SQUARE FOOTAGE: 5,023
 BLDG. ENV. WIDTH AT SETBACK: 43.0'

BSE1921\Final Plat\sales maps.dwg

LOT 15
 TERRAVESSA
 FITCHBURG LANDS, LLC

DATE 12-13-2018	PROJECT NO. BSE1921
SCALE 1" = 40'	
IF THIS BAR DOES NOT MEASURE 1" THEN DRAWING IS NOT TO SCALE	

Burse
 surveying & engineering LLC
 2801 International Lane, Suite 101
 Madison, WI 53704 608.250.9263
 Fax: 608.250.9266
 email: mburse@bse-inc.net
 www.bursesurveyengr.com

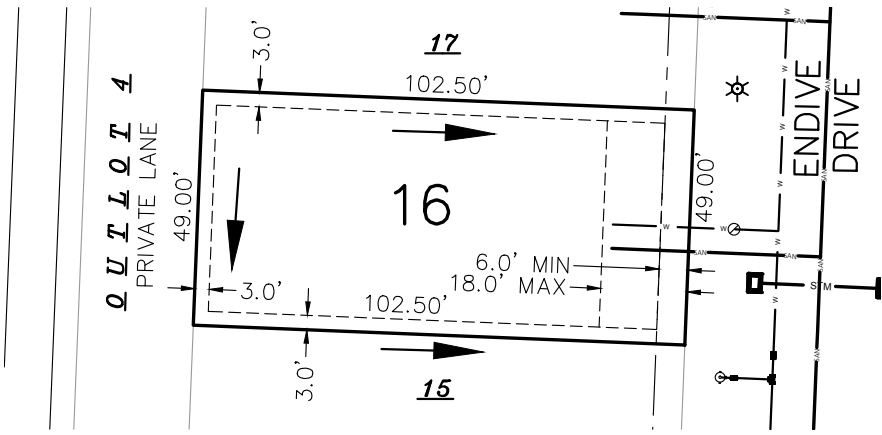

LEGEND

- SURFACE DRAINAGE SWALE DIRECTION
- BUILDING SETBACK LINE
- WATER SERVICE (PROPOSED)
- SANITARY LATERAL (PROPOSED)
- 6' ELECTRIC AND GAS LINES BELOW GRADE EASEMENT
- 10' UTILITY EASEMENT
- STREET LIGHT

TRANSECT ZONE: T4
 LOT SQUARE FOOTAGE: 5,023
 BLDG. ENV. WIDTH AT SETBACK: 43.0'

BSE1921\Final Plat\sales maps.dwg

LOT 16
 TERRAVESSA
 FITCHBURG LANDS, LLC

DATE 12-13-2018	PROJECT NO. BSE1921
SCALE 1" = 40'	
IF THIS BAR DOES NOT MEASURE 1" THEN DRAWING IS NOT TO SCALE	

Burse
 surveying & engineering ^{LLC}
 2801 International Lane, Suite 101
 Madison, WI 53704 608.250.9263
 Fax: 608.250.9266
 email: mburse@bse-inc.net
 www.bursesurveyengr.com

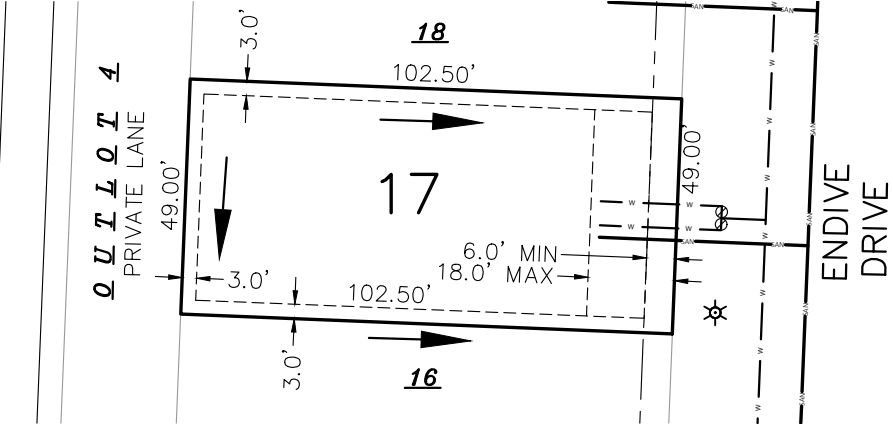

LEGEND

- SURFACE DRAINAGE SWALE DIRECTION
- BUILDING SETBACK LINE
- WATER SERVICE (PROPOSED)
- SANITARY LATERAL (PROPOSED)
- 6' ELECTRIC AND GAS LINES BELOW GRADE EASEMENT
- 10' UTILITY EASEMENT
- STREET LIGHT

TRANSECT ZONE: T4
 LOT SQUARE FOOTAGE: 5,023
 BLDG. ENV. WIDTH AT SETBACK: 43.0'

BSE1921\Final Plat\sales maps.dwg

LOT 17
 TERRAVESSA
 FITCHBURG LANDS, LLC

DATE 12-13-2018	PROJECT NO. BSE1921
SCALE 1" = 40'	
IF THIS BAR DOES NOT MEASURE 1" THEN DRAWING IS NOT TO SCALE	

Burse
 surveying & engineering LLC
 2801 International Lane, Suite 101
 Madison, WI 53704 608.250.9263
 Fax: 608.250.9266
 email: mburse@bse-inc.net
 www.bursesurveyengr.com

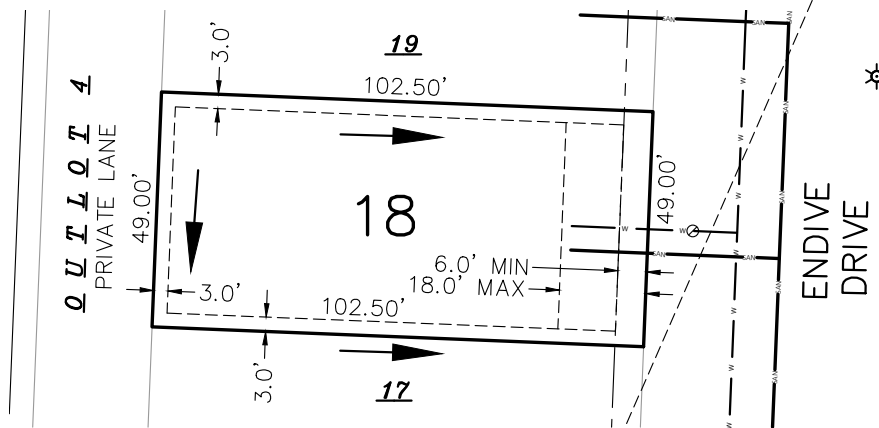

LEGEND

- SURFACE DRAINAGE SWALE DIRECTION
- BUILDING SETBACK LINE
- WATER SERVICE (PROPOSED)
- SANITARY LATERAL (PROPOSED)
- 6' ELECTRIC AND GAS LINES BELOW GRADE EASEMENT
- 10' UTILITY EASEMENT
- STREET LIGHT

TRANSECT ZONE: T4
 LOT SQUARE FOOTAGE: 5,023
 BLDG. ENV. WIDTH AT SETBACK: 43.0'

BSE1921\Final Plat\sales maps.dwg

LOT 18
 TERRAVESSA
 FITCHBURG LANDS, LLC

DATE 12-13-2018	PROJECT NO. BSE1921
SCALE 1" = 40'	
IF THIS BAR DOES NOT MEASURE 1" THEN DRAWING IS NOT TO SCALE	

Burse
 surveying & engineering LLC
 2801 International Lane, Suite 101
 Madison, WI 53704 608.250.9263
 Fax: 608.250.9266
 email: mburse@bse-inc.net
 www.bursesurveyengr.com

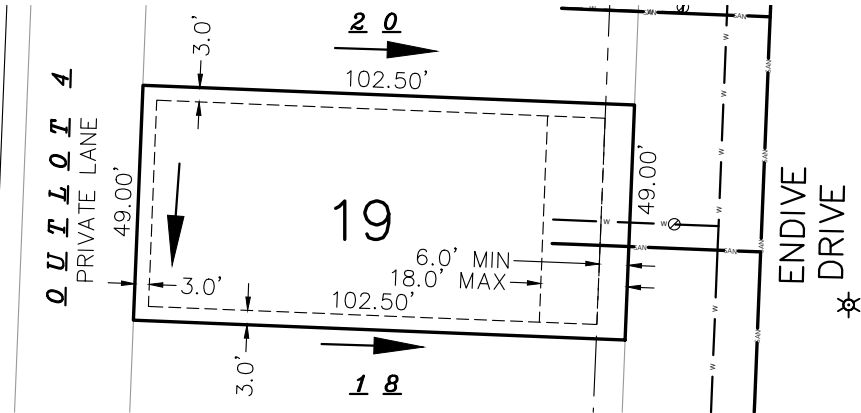

LEGEND

- SURFACE DRAINAGE SWALE DIRECTION
- BUILDING SETBACK LINE
- WATER SERVICE (PROPOSED)
- SANITARY LATERAL (PROPOSED)
- 6' ELECTRIC AND GAS LINES BELOW GRADE EASEMENT
- 10' UTILITY EASEMENT
- STREET LIGHT

TRANSECT ZONE: T4
 LOT SQUARE FOOTAGE: 5,023
 BLDG. ENV. WIDTH AT SETBACK: 43.0'

BSE1921\Final Plat\sales maps.dwg

LOT 19
 TERRAVESSA
 FITCHBURG LANDS, LLC

DATE 12-13-2018	PROJECT NO. BSE1921
SCALE 1" = 40'	
IF THIS BAR DOES NOT MEASURE 1" THEN DRAWING IS NOT TO SCALE	

Burse
 surveying & engineering LLC
 2801 International Lane, Suite 101
 Madison, WI 53704 608.250.9263
 Fax: 608.250.9266
 email: mburse@bse-inc.net
 www.bursesurveyengr.com

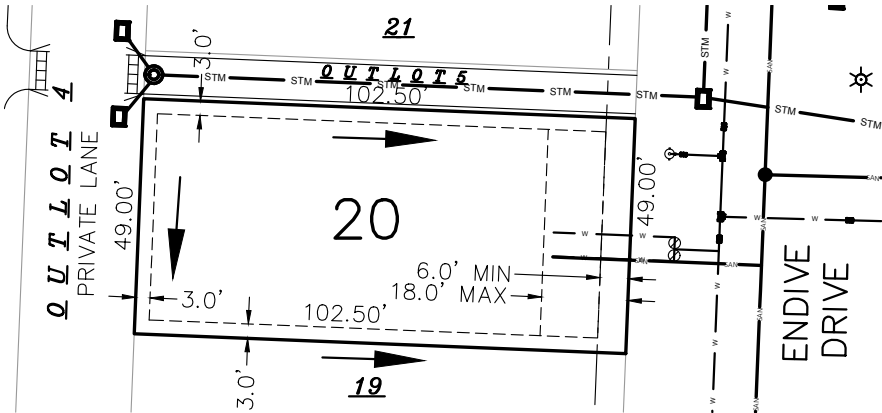

LEGEND

- SURFACE DRAINAGE SWALE DIRECTION
- BUILDING SETBACK LINE
- WATER SERVICE (PROPOSED)
- SANITARY LATERAL (PROPOSED)
- 6' ELECTRIC AND GAS LINES BELOW GRADE EASEMENT
- 10' UTILITY EASEMENT
- STREET LIGHT

TRANSECT ZONE: T4
 LOT SQUARE FOOTAGE: 5,023
 BLDG. ENV. WIDTH AT SETBACK: 43.0'

BSE1921\Final Plat\sales maps.dwg

LOT 20
 TERRAVESSA
 FITCHBURG LANDS, LLC

DATE 12-13-2018	PROJECT NO. BSE1921
SCALE 1" = 40'	
IF THIS BAR DOES NOT MEASURE 1" THEN DRAWING IS NOT TO SCALE	

Burse
 surveying & engineering LLC
 2801 International Lane, Suite 101
 Madison, WI 53704 G08.250.9263
 Fax: G08.250.9266
 email: mburse@bse-inc.net
 www.bursesurveyengr.com

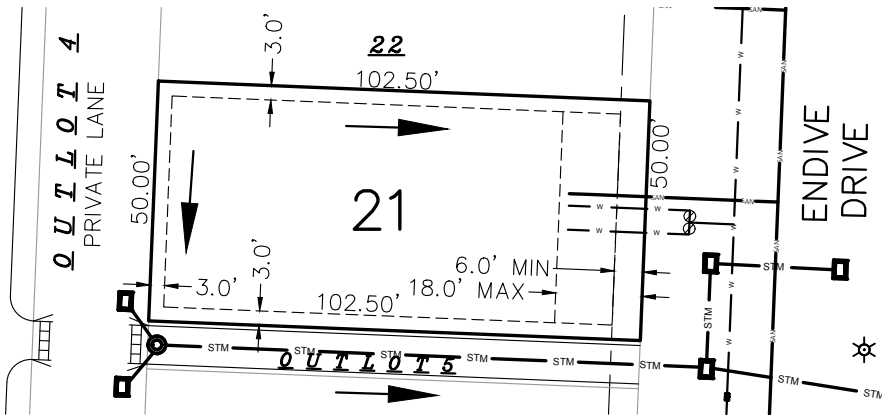

LEGEND

- SURFACE DRAINAGE SWALE DIRECTION
- BUILDING SETBACK LINE
- WATER SERVICE (PROPOSED)
- SANITARY LATERAL (PROPOSED)
- 6' ELECTRIC AND GAS LINES BELOW GRADE EASEMENT
- 10' UTILITY EASEMENT
- STREET LIGHT

TRANSECT ZONE: T4
 LOT SQUARE FOOTAGE: 5,125
 BLDG. ENV. WIDTH AT SETBACK: 44.0'

BSE1921\Final Plat\sales maps.dwg

LOT 21
 TERRAVESSA
 FITCHBURG LANDS, LLC

DATE 12-13-2018	PROJECT NO. BSE1921
SCALE 1" = 40'	
IF THIS BAR DOES NOT MEASURE 1" THEN DRAWING IS NOT TO SCALE	

Burse
 surveying & engineering LLC
 2801 International Lane, Suite 101
 Madison, WI 53704 608.250.9263
 Fax: 608.250.9266
 email: mburse@bse-inc.net
 www.bursesurveyengr.com

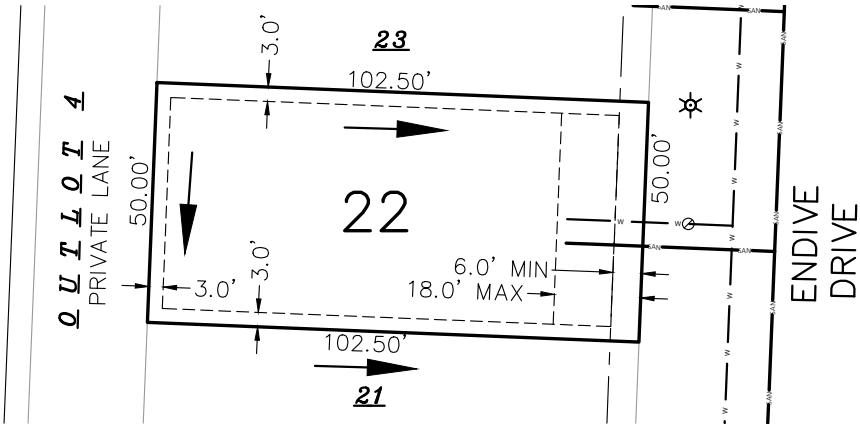

LEGEND

- SURFACE DRAINAGE SWALE DIRECTION
- BUILDING SETBACK LINE
- WATER SERVICE (PROPOSED)
- SANITARY LATERAL (PROPOSED)
- 6' ELECTRIC AND GAS LINES BELOW GRADE EASEMENT
- 10' UTILITY EASEMENT
- STREET LIGHT

TRANSECT ZONE: T4
 LOT SQUARE FOOTAGE: 5,125
 BLDG. ENV. WIDTH AT SETBACK: 44.0'

LOT 22
 TERRAVESSA
 FITCHBURG LANDS, LLC

DATE 01-31-2017	PROJECT NO. BSE1921
SCALE 1" = 40'	
IF THIS BAR DOES NOT MEASURE 1" THEN DRAWING IS NOT TO SCALE	

Burse
 surveying & engineering LLC
 2801 International Lane, Suite 101
 Madison, WI 53704 608.250.9263
 Fax: 608.250.9266
 email: mburse@bse-inc.net
 www.bursesurveyengr.com

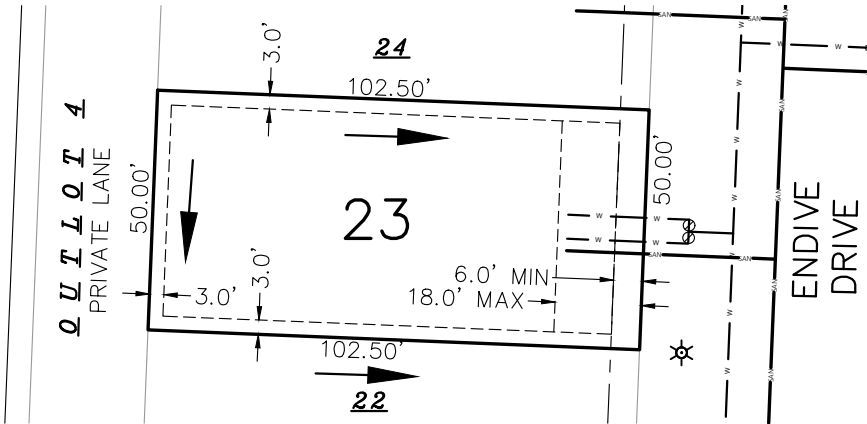

LEGEND

- SURFACE DRAINAGE SWALE DIRECTION
- BUILDING SETBACK LINE
- WATER SERVICE (PROPOSED)
- SANITARY LATERAL (PROPOSED)
- 6' ELECTRIC AND GAS LINES BELOW GRADE EASEMENT
- 10' UTILITY EASEMENT
- STREET LIGHT

TRANSECT ZONE: T4
 LOT SQUARE FOOTAGE: 5,125
 BLDG. ENV. WIDTH AT SETBACK: 44.0'

BSE1921\Final Plat\sales maps.dwg

LOT 23
 TERRAVESSA
 FITCHBURG LANDS, LLC

DATE 12-13-2018	PROJECT NO. BSE1921
SCALE 1" = 40'	
IF THIS BAR DOES NOT MEASURE 1" THEN DRAWING IS NOT TO SCALE	

Burse
 surveying & engineering LLC
 2801 International Lane, Suite 101
 Madison, WI 53704 608.250.9263
 Fax: 608.250.9266
 email: mburse@bse-inc.net
 www.bursesurveyengr.com

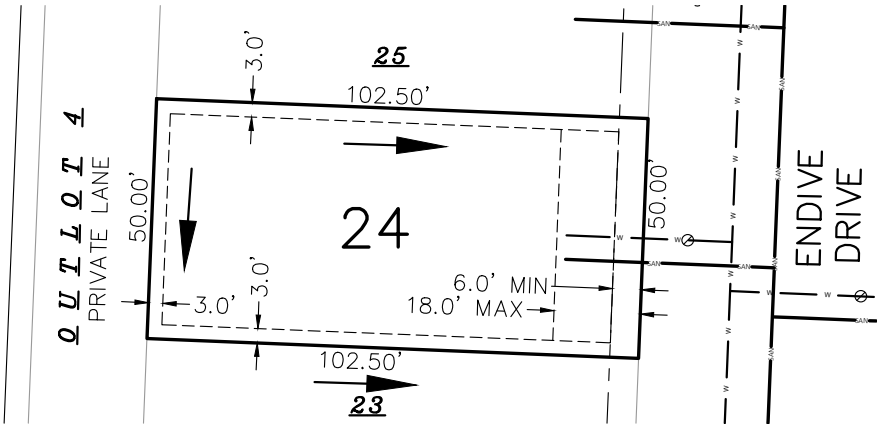

LEGEND

- SURFACE DRAINAGE SWALE DIRECTION
- BUILDING SETBACK LINE
- WATER SERVICE (PROPOSED)
- SANITARY LATERAL (PROPOSED)
- 6' ELECTRIC AND GAS LINES BELOW GRADE EASEMENT
- 10' UTILITY EASEMENT
- STREET LIGHT

TRANSECT ZONE: T4
 LOT SQUARE FOOTAGE: 5,125
 BLDG. ENV. WIDTH AT SETBACK: 43.0'

BSE1921\Final Plat\sales maps.dwg

LOT 24
 TERRAVESSA
 FITCHBURG LANDS, LLC

DATE 12-13-2018	PROJECT NO. BSE1921
SCALE 1" = 40'	
IF THIS BAR DOES NOT MEASURE 1" THEN DRAWING IS NOT TO SCALE	

Burse
 surveying & engineering LLC
 2801 International Lane, Suite 101
 Madison, WI 53704 608.250.9263
 Fax: 608.250.9266
 email: mburse@bse-inc.net
 www.bursesurveyengr.com

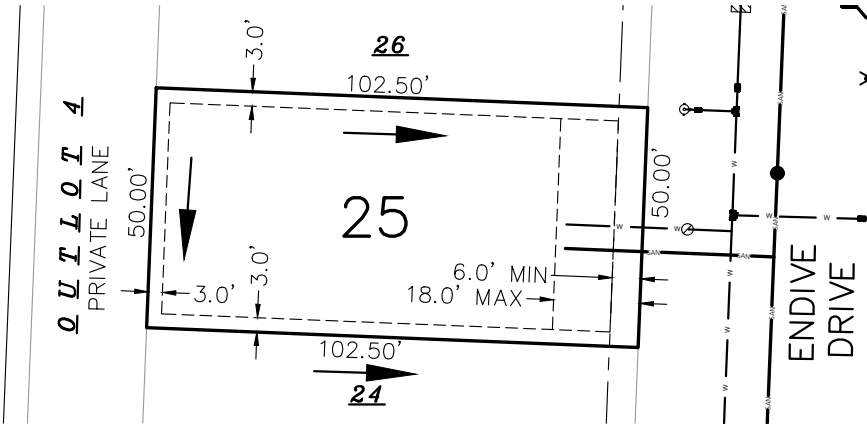

LEGEND

- SURFACE DRAINAGE SWALE DIRECTION
- BUILDING SETBACK LINE
- WATER SERVICE (PROPOSED)
- SANITARY LATERAL (PROPOSED)
- 6' ELECTRIC AND GAS LINES BELOW GRADE EASEMENT
- 10' UTILITY EASEMENT
- STREET LIGHT

TRANSECT ZONE: T4
 LOT SQUARE FOOTAGE: 5,125
 BLDG. ENV. WIDTH AT SETBACK: 44.0'

BSE1921\Final Plat\sales maps.dwg

LOT 25
 TERRAVESSA
 FITCHBURG LANDS, LLC

DATE 12-13-2018	PROJECT NO. BSE1921
SCALE 1" = 40'	
IF THIS BAR DOES NOT MEASURE 1" THEN DRAWING IS NOT TO SCALE	

Burse
 surveying & engineering LLC
 2801 International Lane, Suite 101
 Madison, WI 53704 608.250.9263
 Fax: 608.250.9266
 email: mburse@bse-inc.net
 www.bursesurveyengr.com

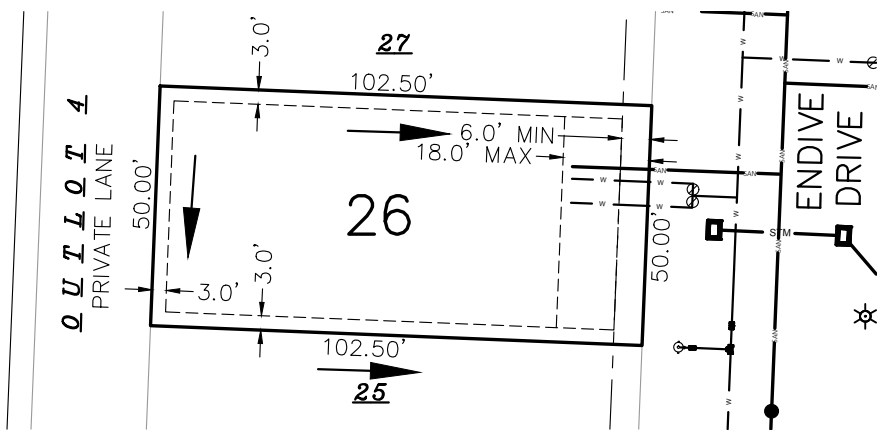

LEGEND

- SURFACE DRAINAGE SWALE DIRECTION
- BUILDING SETBACK LINE
- WATER SERVICE (PROPOSED)
- SANITARY LATERAL (PROPOSED)
- 6' ELECTRIC AND GAS LINES BELOW GRADE EASEMENT
- 10' UTILITY EASEMENT
- STREET LIGHT

TRANSECT ZONE: T4
 LOT SQUARE FOOTAGE: 5,125
 BLDG. ENV. WIDTH AT SETBACK: 44.0'

BSE1921\Final Plat\sales maps.dwg

LOT 26
 TERRAVESSA
 FITCHBURG LANDS, LLC

DATE 12-13-2018	PROJECT NO. BSE1921
SCALE 1" = 40'	
IF THIS BAR DOES NOT MEASURE 1" THEN DRAWING IS NOT TO SCALE	

Burse
 surveying & engineering LLC
 2801 International Lane, Suite 101
 Madison, WI 53704 608.250.9263
 Fax: 608.250.9266
 email: mburse@bse-inc.net
 www.bursesurveyengr.com

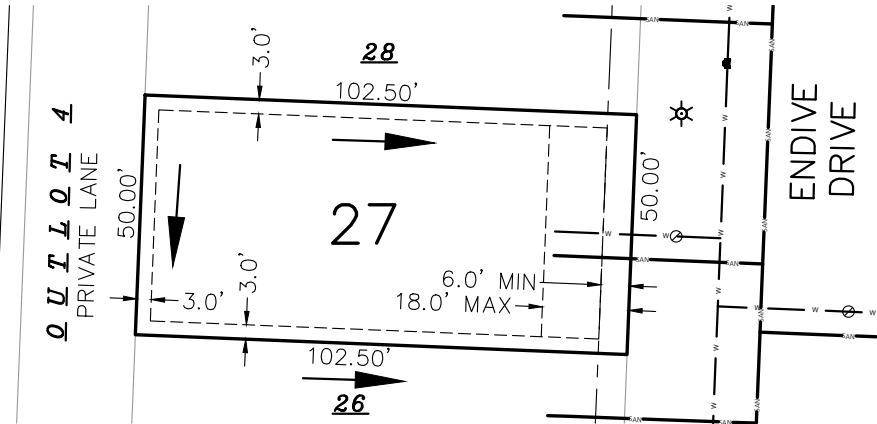

LEGEND

- SURFACE DRAINAGE SWALE DIRECTION
- BUILDING SETBACK LINE
- WATER SERVICE (PROPOSED)
- SANITARY LATERAL (PROPOSED)
- 6' ELECTRIC AND GAS LINES BELOW GRADE EASEMENT
- 10' UTILITY EASEMENT
- STREET LIGHT

TRANSECT ZONE: T4
 LOT SQUARE FOOTAGE: 5,125
 BLDG. ENV. WIDTH AT SETBACK: 44.0'

BSE1921\Final Plat\sales maps.dwg

LOT 27
 TERRAVESSA
 FITCHBURG LANDS, LLC

DATE 12-13-2018	PROJECT NO. BSE1921
SCALE 1" = 40'	
IF THIS BAR DOES NOT MEASURE 1" THEN DRAWING IS NOT TO SCALE	

Burse
 surveying & engineering LLC
 2801 International Lane, Suite 101
 Madison, WI 53704 608.250.9263
 Fax: 608.250.9266
 email: mburse@bse-inc.net
 www.bursesurveyengr.com

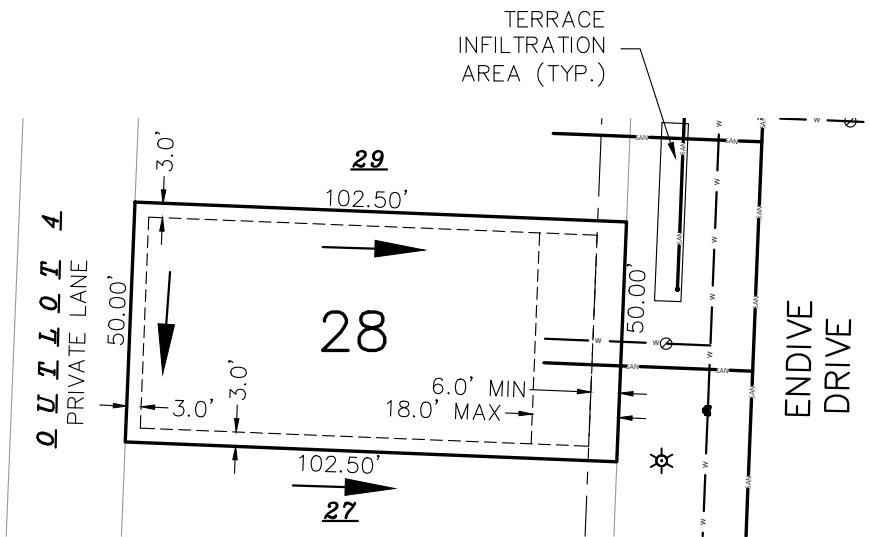

LEGEND

- SURFACE DRAINAGE SWALE DIRECTION
- BUILDING SETBACK LINE
- WATER SERVICE (PROPOSED)
- SANITARY LATERAL (PROPOSED)
- 6' ELECTRIC AND GAS LINES BELOW GRADE EASEMENT
- 10' UTILITY EASEMENT
- STREET LIGHT

TRANSECT ZONE: T4
 LOT SQUARE FOOTAGE: 5,125
 BLDG. ENV. WIDTH AT SETBACK: 44.0'

BSE1921\Final Plat\sales maps.dwg

LOT 28
 TERRAVESSA
 FITCHBURG LANDS, LLC

DATE 12-13-2018	PROJECT NO. BSE1921
SCALE 1" = 40'	
IF THIS BAR DOES NOT MEASURE 1" THEN DRAWING IS NOT TO SCALE	

Burse
 surveying & engineering LLC
 2801 International Lane, Suite 101
 Madison, WI 53704 608.250.9263
 Fax: 608.250.9266
 email: mburse@bse-inc.net
 www.bursesurveyengr.com

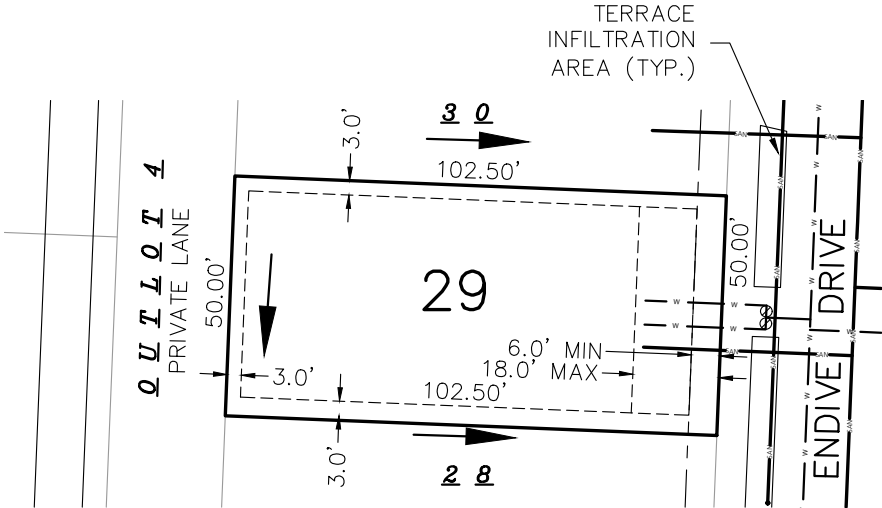

LEGEND

- SURFACE DRAINAGE SWALE DIRECTION
- BUILDING SETBACK LINE
- WATER SERVICE (PROPOSED)
- SANITARY LATERAL (PROPOSED)
- 6' ELECTRIC AND GAS LINES BELOW GRADE EASEMENT
- 10' UTILITY EASEMENT
- STREET LIGHT



TRANSECT ZONE: T4
 LOT SQUARE FOOTAGE: 5,125
 BLDG. ENV. WIDTH AT SETBACK: 44.0'

BSE1921\Final Plat\sales maps.dwg

LOT 29
 TERRAVESSA
 FITCHBURG LANDS, LLC

DATE 12-13-2018	PROJECT NO. BSE1921
SCALE 1" = 40'	
IF THIS BAR DOES NOT MEASURE 1" THEN DRAWING IS NOT TO SCALE	

Burse
 surveying & engineering LLC
 2801 International Lane, Suite 101
 Madison, WI 53704 608.250.9263
 Fax: 608.250.9266
 email: mburse@bse-inc.net
 www.bursesurveyengr.com

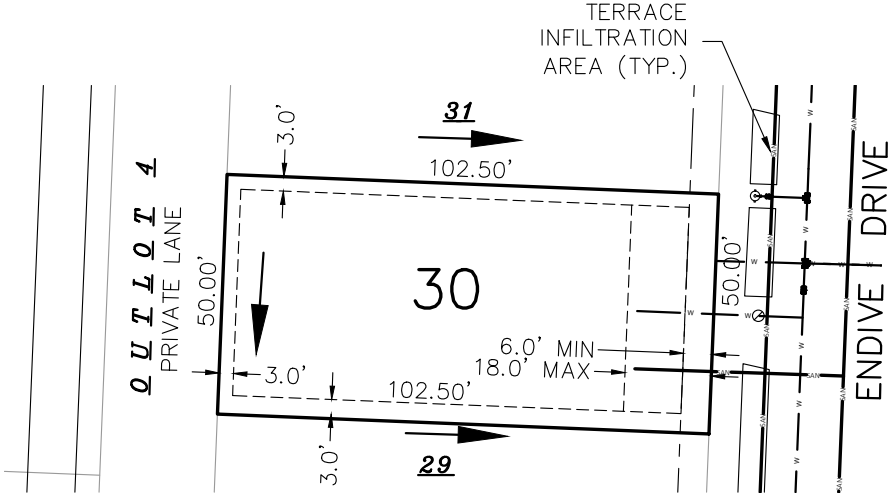

LEGEND

- SURFACE DRAINAGE SWALE DIRECTION
- BUILDING SETBACK LINE
- WATER SERVICE (PROPOSED)
- SANITARY LATERAL (PROPOSED)
- 6' ELECTRIC AND GAS LINES BELOW GRADE EASEMENT
- 10' UTILITY EASEMENT
- STREET LIGHT

TRANSECT ZONE: T4
 LOT SQUARE FOOTAGE: 5,125
 BLDG. ENV. WIDTH AT SETBACK: 44.0'

BSE1921\Final Plat\sales maps.dwg

LOT 30
 TERRAVESSA
 FITCHBURG LANDS, LLC

DATE 12-13-2018	PROJECT NO. BSE1921
SCALE 1" = 40'	
IF THIS BAR DOES NOT MEASURE 1" THEN DRAWING IS NOT TO SCALE	

Burse
 surveying & engineering LLC
 2801 International Lane, Suite 101
 Madison, WI 53704 608.250.9263
 Fax: 608.250.9266
 email: mburse@bse-inc.net
 www.bursesurveyengr.com

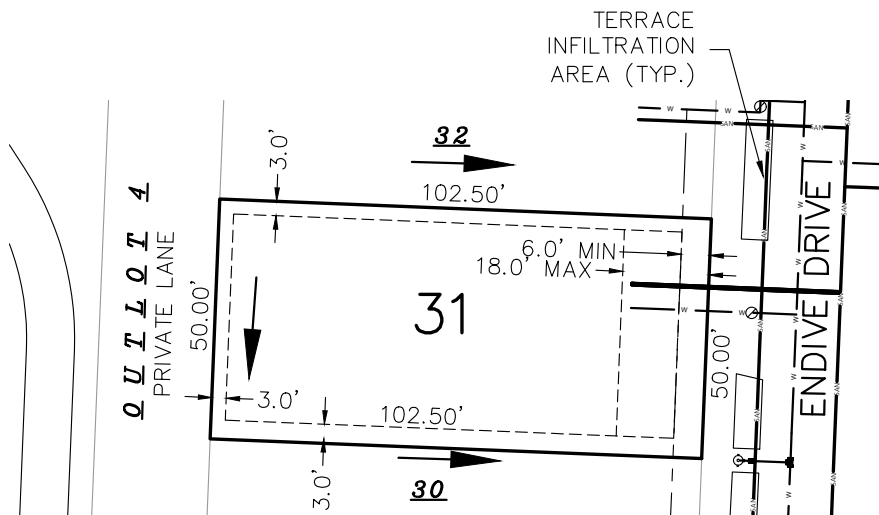

LEGEND

- SURFACE DRAINAGE SWALE DIRECTION
- BUILDING SETBACK LINE
- WATER SERVICE (PROPOSED)
- SANITARY LATERAL (PROPOSED)
- 6' ELECTRIC AND GAS LINES BELOW GRADE EASEMENT
- 10' UTILITY EASEMENT
- STREET LIGHT



TRANSECT ZONE: T4
 LOT SQUARE FOOTAGE: 5,125
 BLDG. ENV. WIDTH AT SETBACK: 44.0'

BSE1921\Final Plat\sales maps.dwg

LOT 31
 TERRAVESSA
 FITCHBURG LANDS, LLC

DATE 12-13-2018	PROJECT NO. BSE1921
SCALE 1" = 40'	
IF THIS BAR DOES NOT MEASURE 1" THEN DRAWING IS NOT TO SCALE	

Burse
 surveying & engineering LLC
 2801 International Lane, Suite 101
 Madison, WI 53704 608.250.9263
 Fax: 608.250.9266
 email: mburse@bse-inc.net
 www.bursesurveyengr.com

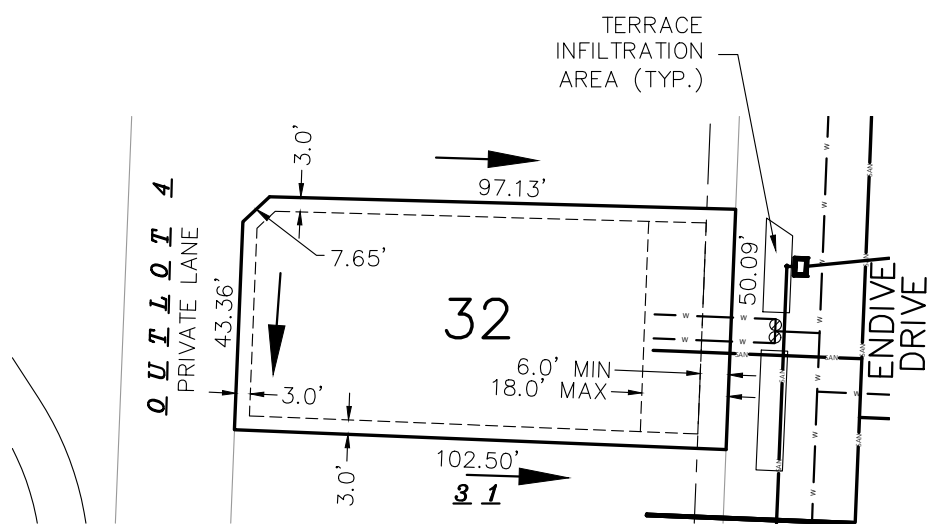

LEGEND

- SURFACE DRAINAGE SWALE DIRECTION
- BUILDING SETBACK LINE
- WATER SERVICE (PROPOSED)
- SANITARY LATERAL (PROPOSED)
- 6' ELECTRIC AND GAS LINES BELOW GRADE EASEMENT
- 10' UTILITY EASEMENT
- STREET LIGHT

TRANSECT ZONE: T4
 LOT SQUARE FOOTAGE: 5,050
 BLDG. ENV. WIDTH AT SETBACK: 44.1'

BSE1921\Final Plat\sales maps.dwg

LOT 32
 TERRAVESSA
 FITCHBURG LANDS, LLC

DATE 12-13-2018	PROJECT NO. BSE1921
SCALE 1" = 40'	
IF THIS BAR DOES NOT MEASURE 1" THEN DRAWING IS NOT TO SCALE	

Burse
 surveying & engineering LLC
 2801 International Lane, Suite 101
 Madison, WI 53704 608.250.9263
 Fax: 608.250.9266
 email: mburse@bse-inc.net
 www.bursesurveyengr.com

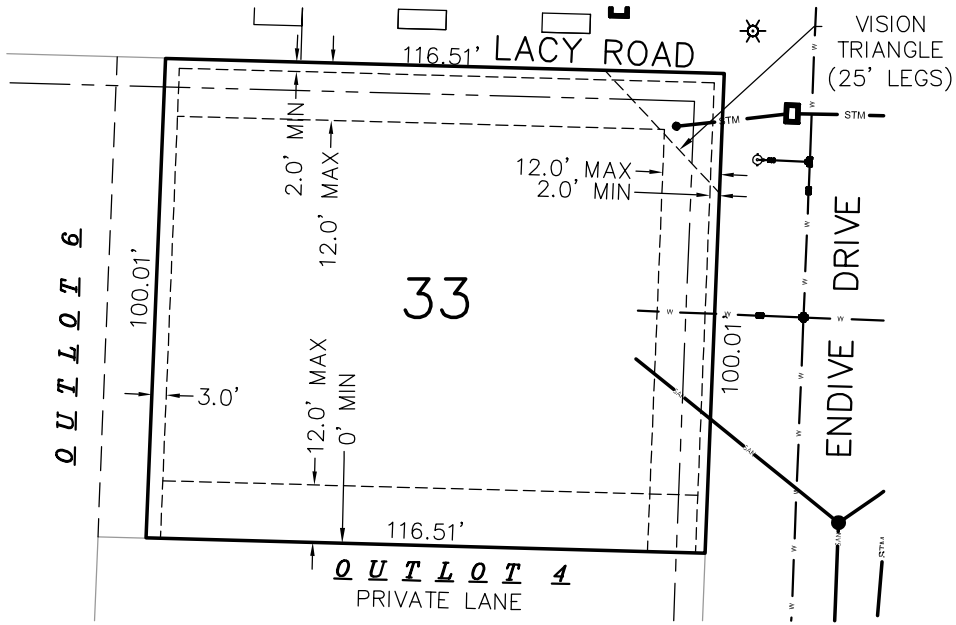

LEGEND

- SURFACE DRAINAGE SWALE DIRECTION
- BUILDING SETBACK LINE
- WATER SERVICE (PROPOSED)
- SANITARY LATERAL (PROPOSED)
- 6' ELECTRIC AND GAS LINES BELOW GRADE EASEMENT
- 10' UTILITY EASEMENT
- STREET LIGHT



TRANSECT ZONE: 5
 LOT SQUARE FOOTAGE: 11,651
 BLDG. ENV. WIDTH AT SETBACK: 98.0'

NOTE:
 AREAS DELINEATED AS VISION TRIANGLE AREAS
 SHALL HAVE NO PLANTINGS OVER TWO (2) FEET
 IN HEIGHT.

TYPICAL VISION CORNER DETAIL

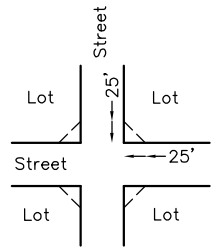

BSE1921\Final Plat\sales maps.dwg

LOT 33
 TERRAVESSA
 FITCHBURG LANDS, LLC

DATE 08-05-2019	PROJECT NO. BSE1921
SCALE 1"=40'	
IF THIS BAR DOES NOT MEASURE 1" THEN DRAWING IS NOT TO SCALE	

Burse
 surveying & engineering Inc.
 2801 International Lane, Suite 101
 Madison, WI 53704 608.250.9263
 Fax: 608.250.9266
 email: mburse@bse-inc.net
 www.bursesurveyengr.com

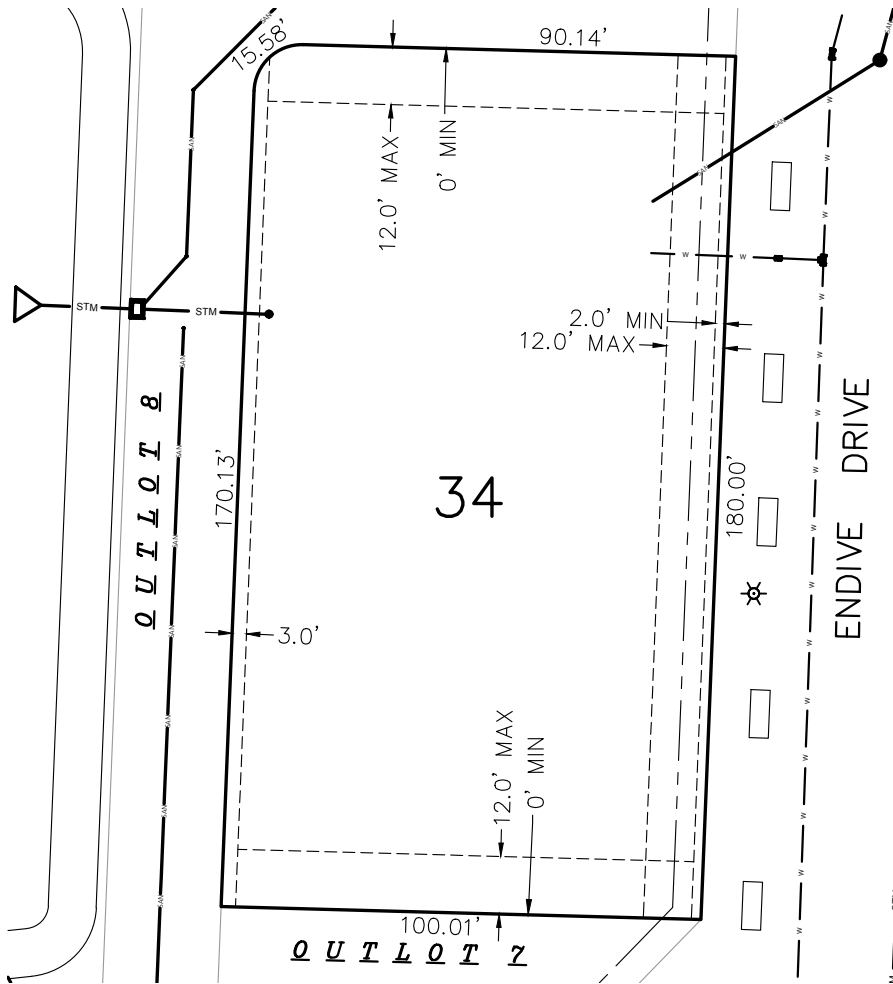

LEGEND

- SURFACE DRAINAGE SWALE DIRECTION
- BUILDING SETBACK LINE
- WATER SERVICE (PROPOSED)
- SANITARY LATERAL (PROPOSED)
- 6' ELECTRIC AND GAS LINES BELOW GRADE EASEMENT
- 10' UTILITY EASEMENT
- STREET LIGHT

TRANSECT ZONE: 5
 LOT SQUARE FOOTAGE: 17,979
 BLDG. ENV. WIDTH AT SETBACK: 180.0'

LOT 34
 TERRAVESSA
 FITCHBURG LANDS, LLC

DATE 12-13-2018	PROJECT NO. BSE1921
SCALE 1" = 40'	
IF THIS BAR DOES NOT MEASURE 1" THEN DRAWING IS NOT TO SCALE	

Burse
 surveying & engineering LLC
 2801 International Lane, Suite 101
 Madison, WI 53704 608.250.9263
 Fax: 608.250.9266
 email: mburse@bse-inc.net
 www.bursesurveyengr.com

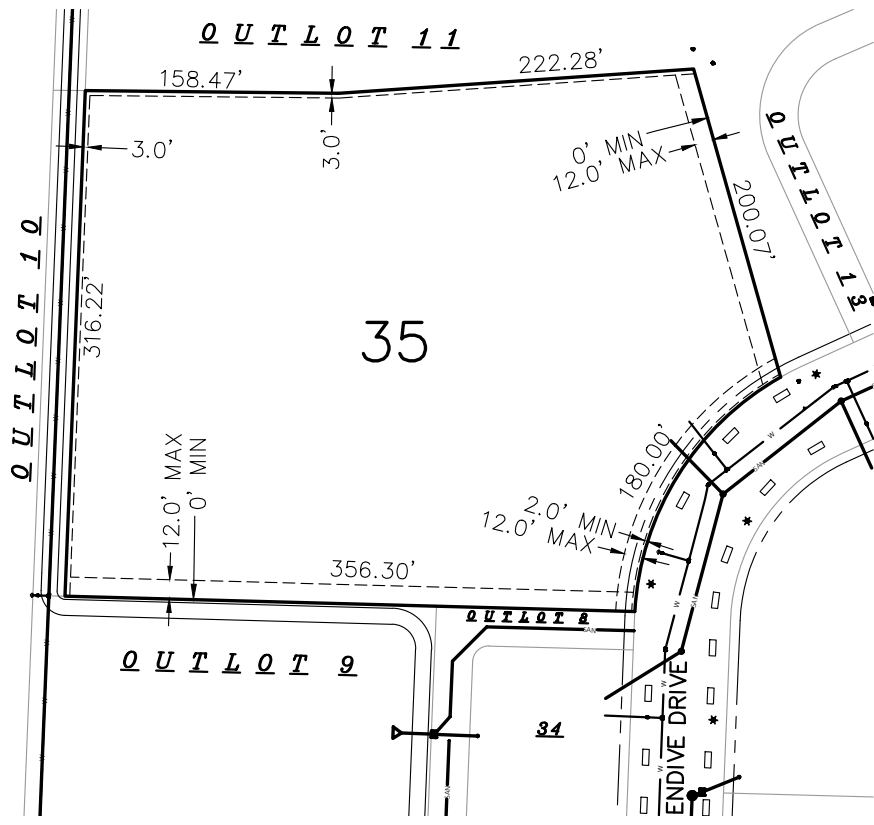

LEGEND

- SURFACE DRAINAGE SWALE DIRECTION
- BUILDING SETBACK LINE
- WATER SERVICE (PROPOSED)
- SANITARY LATERAL (PROPOSED)
- 6' ELECTRIC AND GAS LINES BELOW GRADE EASEMENT
- 10' UTILITY EASEMENT
- STREET LIGHT

TRANSECT ZONE: 5
 LOT SQUARE FOOTAGE: 129,360
 BLDG. ENV. WIDTH AT SETBACK:

BSE1921\Final Plat\sales maps.dwg

LOT 35
 TERRAVESSA
 FITCHBURG LANDS, LLC

DATE 12-13-2018	PROJECT NO. BSE1921
SCALE 1"=120'	
IF THIS BAR DOES NOT MEASURE 1" THEN DRAWING IS NOT TO SCALE	

Burse
 surveying & engineering LLC
 2801 International Lane, Suite 101
 Madison, WI 53704 608.250.9263
 Fax: 608.250.9266
 email: mburse@bse-inc.net
 www.bursesurveyengr.com

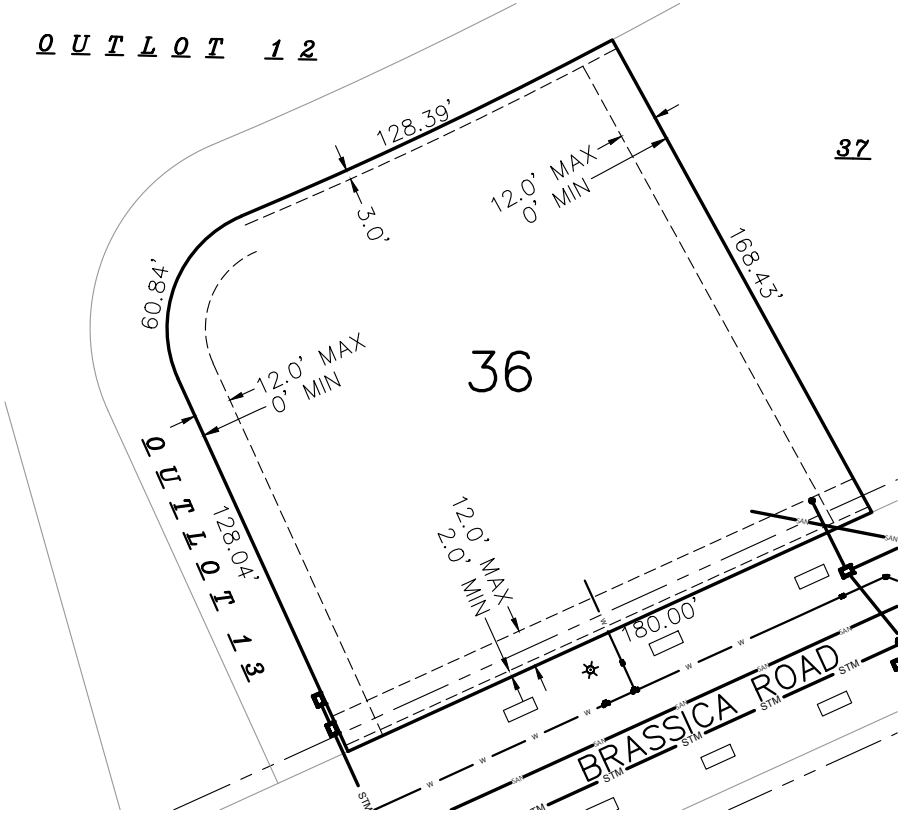

LEGEND	
	SURFACE DRAINAGE SWALE DIRECTION
	BUILDING SETBACK LINE
	WATER SERVICE (PROPOSED)
	SANITARY LATERAL (PROPOSED)
	6' ELECTRIC AND GAS LINES BELOW GRADE EASEMENT
	10' UTILITY EASEMENT
	STREET LIGHT

TRANSECT ZONE: T5
 LOT SQUARE FOOTAGE: 28,547
 BLDG. ENV. WIDTH AT SETBACK:



BSE1921\Final Plat\sales maps.dwg

LOT 36
 TERRAVESSA
 FITCHBURG LANDS, LLC

DATE 12-13-2018	PROJECT NO. BSE1921
SCALE 1"=60'	
IF THIS BAR DOES NOT MEASURE 1" THEN DRAWING IS NOT TO SCALE	

Burse
 surveying & engineering LLC
 2801 International Lane, Suite 101
 Madison, WI 53704 608.250.9263
 Fax: 608.250.9266
 email: mburse@bse-inc.net
 www.bursesurveyengr.com

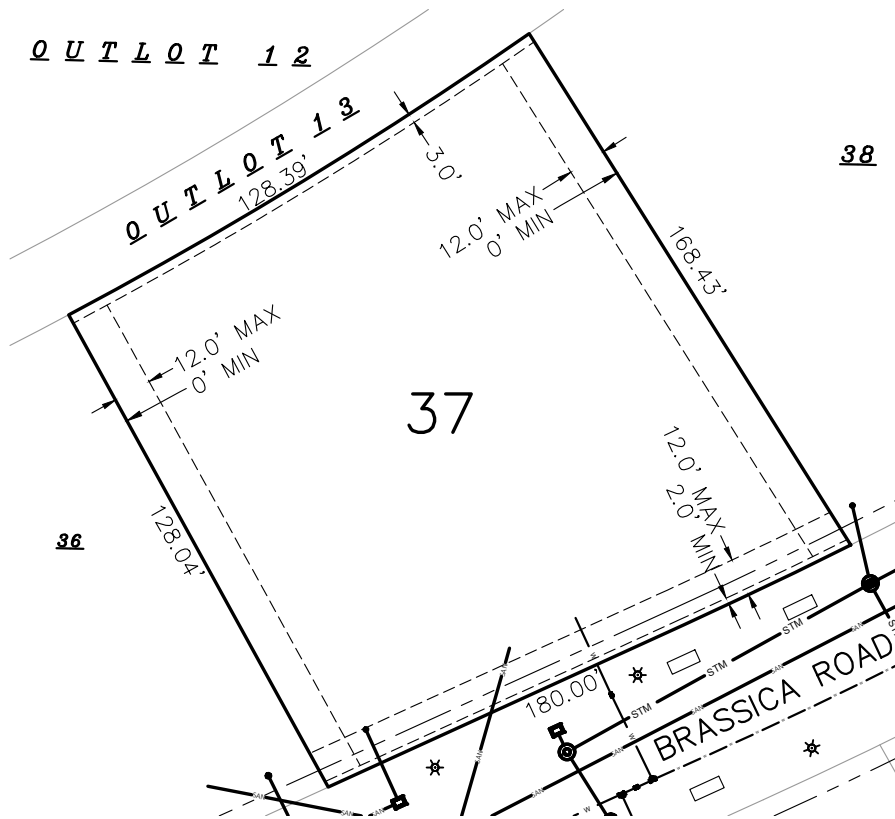

LEGEND	
	SURFACE DRAINAGE SWALE DIRECTION
	BUILDING SETBACK LINE
	WATER SERVICE (PROPOSED)
	SANITARY LATERAL (PROPOSED)
	6' ELECTRIC AND GAS LINES BELOW GRADE EASEMENT
	10' UTILITY EASEMENT
	STREET LIGHT

TRANSECT ZONE: T5
 LOT SQUARE FOOTAGE: 30,829
 BLDG. ENV. WIDTH AT SETBACK: 180.0'

BSE1921\Final Plat\sales maps.dwg

LOT 37
 TERRAVESSA
 FITCHBURG LANDS, LLC

DATE 12-13-2018	PROJECT NO. BSE1921
SCALE 1"=60'	
IF THIS BAR DOES NOT MEASURE 1" THEN DRAWING IS NOT TO SCALE	

Burse
 surveying & engineering LLC
 2801 International Lane, Suite 101
 Madison, WI 53704 608.250.9263
 Fax: 608.250.9266
 email: mburse@bse-inc.net
 www.bursesurveyengr.com

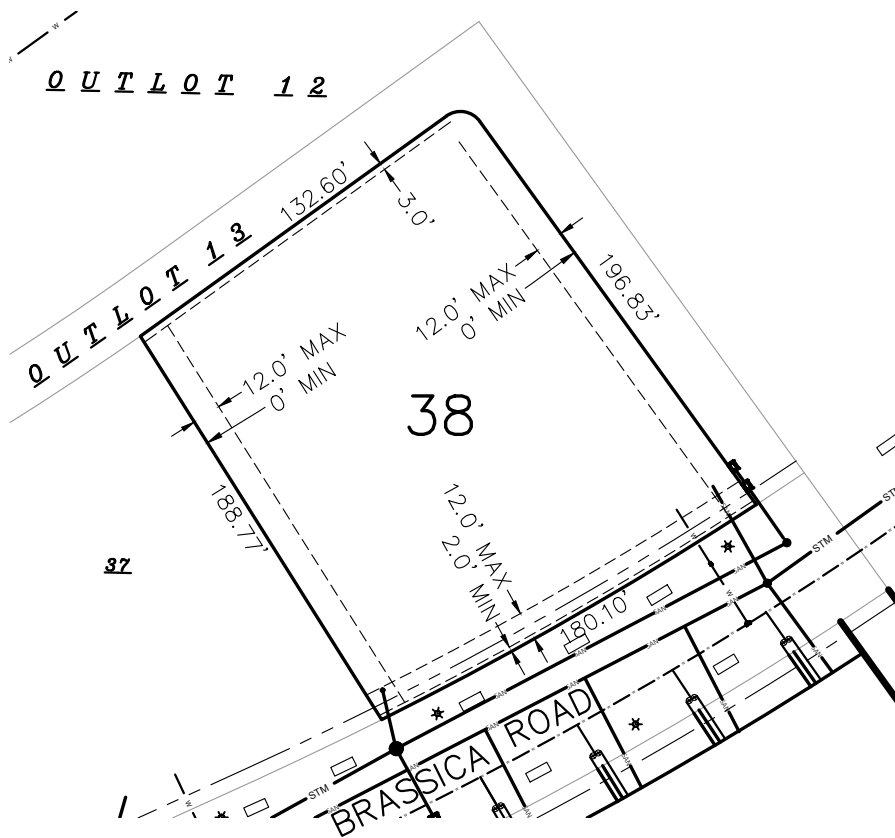

LEGEND	
	SURFACE DRAINAGE SWALE DIRECTION
	BUILDING SETBACK LINE
	WATER SERVICE (PROPOSED)
	SANITARY LATERAL (PROPOSED)
	6' ELECTRIC AND GAS LINES BELOW GRADE EASEMENT
	10' UTILITY EASEMENT
	STREET LIGHT

TRANSECT ZONE: T5
 LOT SQUARE FOOTAGE: 34,527
 BLDG. ENV. WIDTH AT SETBACK: 180.10'

BSE1921\Final Plat\sales maps.dwg

LOT 38
 TERRAVESSA
 FITCHBURG LANDS, LLC

DATE 12-13-2018	PROJECT NO. BSE1921
SCALE 1"=80'	
IF THIS BAR DOES NOT MEASURE 1" THEN DRAWING IS NOT TO SCALE	

Burse
 surveying & engineering LLC
 2801 International Lane, Suite 101
 Madison, WI 53704 G08.250.9263
 Fax: G08.250.9266
 email: mburse@bse-inc.net
 www.bursesurveyengr.com

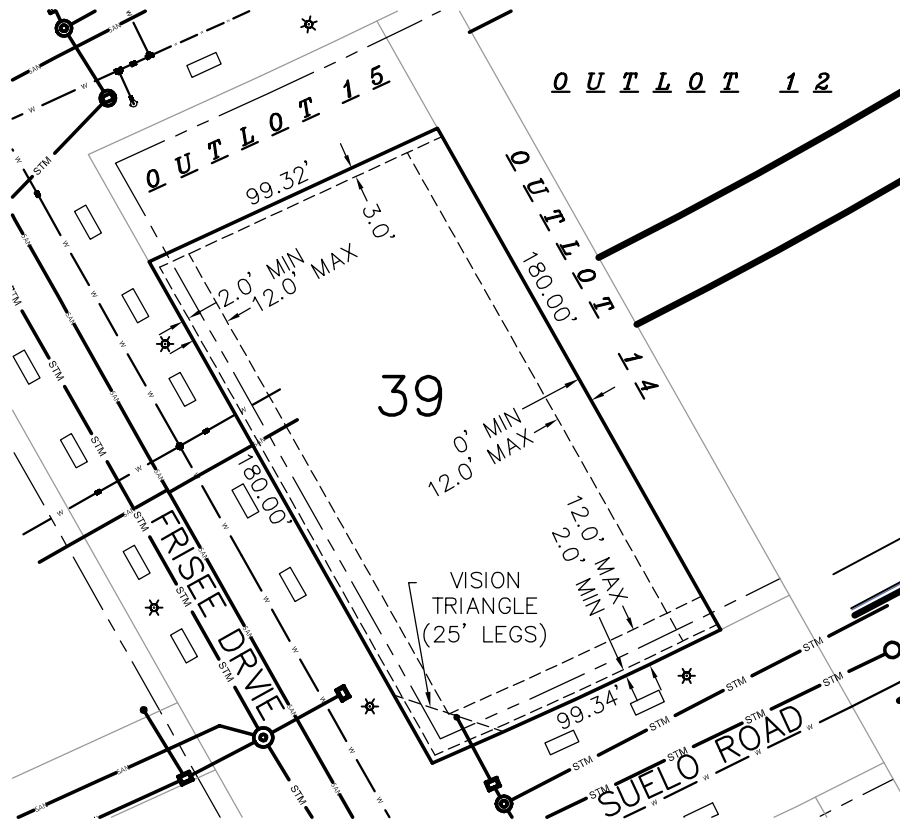

LEGEND

- SURFACE DRAINAGE SWALE DIRECTION
- BUILDING SETBACK LINE
- WATER SERVICE (PROPOSED)
- SANITARY LATERAL (PROPOSED)
- 6' ELECTRIC AND GAS LINES BELOW GRADE EASEMENT
- 10' UTILITY EASEMENT
- STREET LIGHT



TRANSECT ZONE: T5
 LOT SQUARE FOOTAGE: 17,864
 BLDG. ENV. WIDTH AT SETBACK: 97.3'

NOTE:
 AREAS DELINEATED AS VISION TRIANGLE AREAS
 SHALL HAVE NO PLANTINGS OVER TWO (2) FEET
 IN HEIGHT.

TYPICAL VISION CORNER DETAIL

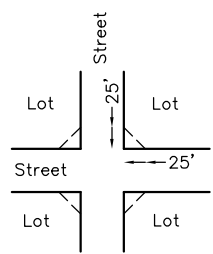

BSE1921\Final Plat\sales maps.dwg

LOT 39
 TERRAVESSA
 FITCHBURG LANDS, LLC

DATE 08-05-2019	PROJECT NO. BSE1921
SCALE 1"=60'	
IF THIS BAR DOES NOT MEASURE 1" THEN DRAWING IS NOT TO SCALE	

Burse
 surveying & engineering Inc.

2801 International Lane, Suite 101
 Madison, WI 53704 608.250.9263
 Fax: 608.250.9266
 email: mburse@bse-inc.net
 www.bursesurveyengr.com

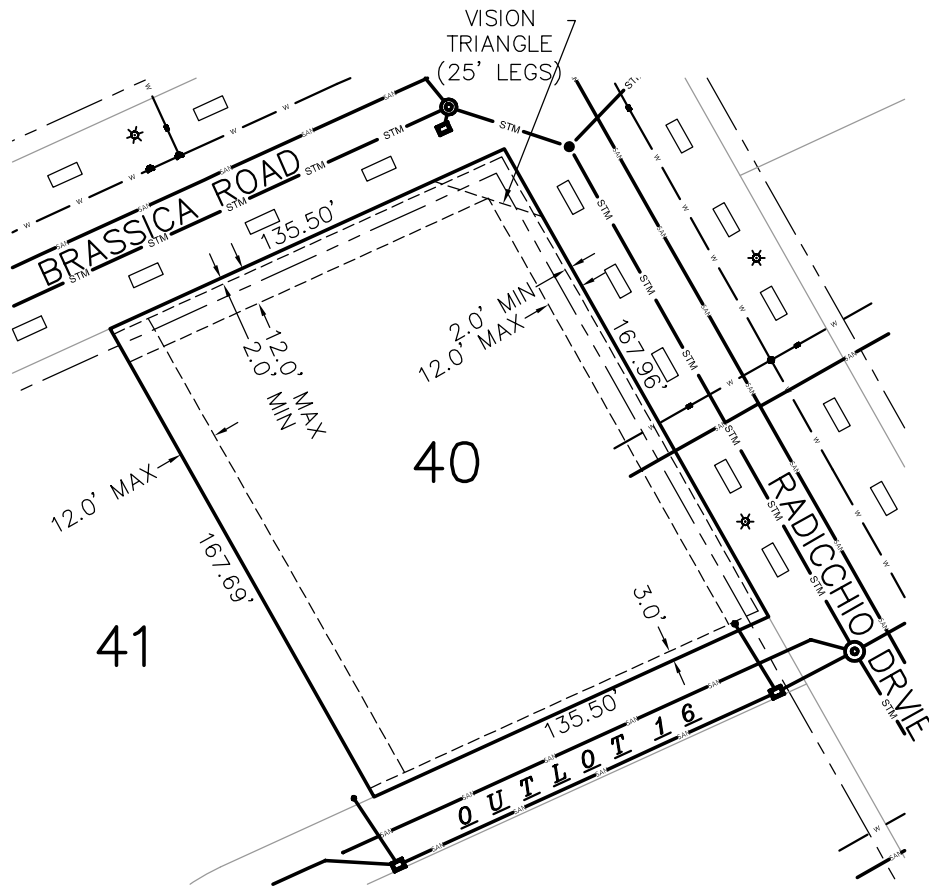

LEGEND

- SURFACE DRAINAGE SWALE DIRECTION
- BUILDING SETBACK LINE
- WATER SERVICE (PROPOSED)
- SANITARY LATERAL (PROPOSED)
- 6' ELECTRIC AND GAS LINES BELOW GRADE EASEMENT
- 10' UTILITY EASEMENT
- STREET LIGHT



TRANSECT ZONE: T5
 LOT SQUARE FOOTAGE: 22,674
 BLDG. ENV. WIDTH AT SETBACK: 132.5'

NOTE:
 AREAS DELINEATED AS VISION TRIANGLE AREAS
 SHALL HAVE NO PLANTINGS OVER TWO (2) FEET
 IN HEIGHT.

TYPICAL VISION CORNER DETAIL

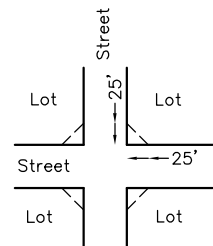

BSE1921\Final Plat\sales maps.dwg

LOT 40
 TERRAVESSA
 FITCHBURG LANDS, LLC

DATE: 08-05-2019 PROJECT NO.: BSE1921

SCALE: 1"=60'

IF THIS BAR DOES NOT MEASURE 1" THEN DRAWING IS NOT TO SCALE

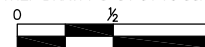

Burse
 surveying & engineering Inc.
 2801 International Lane, Suite 101
 Madison, WI 53704 608.250.9263
 Fax: 608.250.9266
 email: mburse@bse-inc.net
 www.bursesurveyengr.com

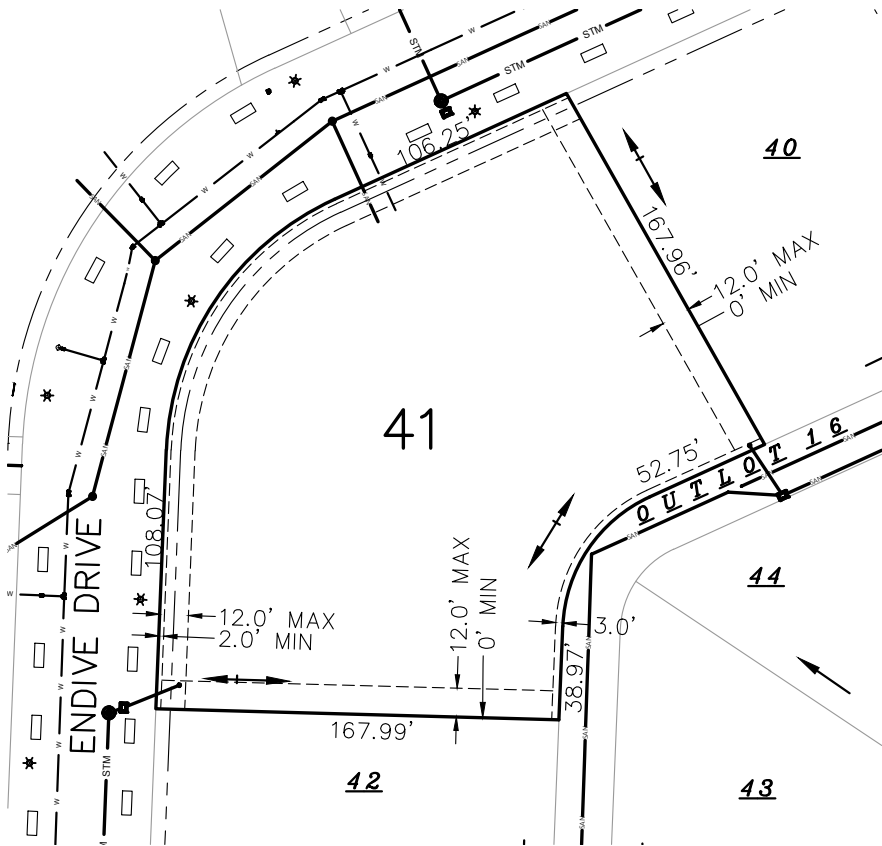

LEGEND

- SURFACE DRAINAGE SWALE DIRECTION
- BUILDING SETBACK LINE
- WATER SERVICE (PROPOSED)
- SANITARY LATERAL (PROPOSED)
- 6' ELECTRIC AND GAS LINES BELOW GRADE EASEMENT
- 10' UTILITY EASEMENT
- STREET LIGHT



TRANSECT ZONE: T5
 LOT SQUARE FOOTAGE: 43,737
 BLDG. ENV. WIDTH AT SETBACK:

BSE1921\Final Plat\sales maps.dwg

LOT 41
 TERRAVESSA
 FITCHBURG LANDS, LLC

DATE 12-13-2018	PROJECT NO. BSE1921
SCALE 1"=80'	
IF THIS BAR DOES NOT MEASURE 1" THEN DRAWING IS NOT TO SCALE	

Burse
 surveying & engineering LLC
 2801 International Lane, Suite 101
 Madison, WI 53704 608.250.9263
 Fax: 608.250.9266
 email: mburse@bse-inc.net
 www.bursesurveyengr.com

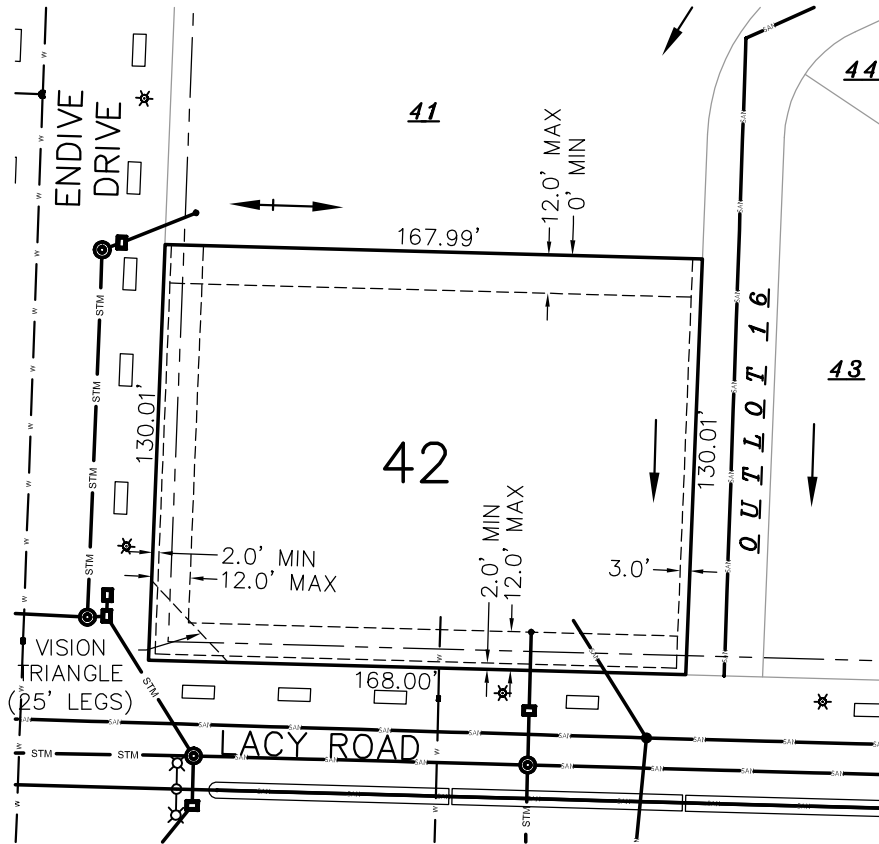

LEGEND

- SURFACE DRAINAGE SWALE DIRECTION
- BUILDING SETBACK LINE
- WATER SERVICE (PROPOSED)
- SANITARY LATERAL (PROPOSED)
- 6' ELECTRIC AND GAS LINES BELOW GRADE EASEMENT
- 10' UTILITY EASEMENT
- STREET LIGHT

TRANSECT ZONE: T5
 LOT SQUARE FOOTAGE: 21,839
 BLDG. ENV. WIDTH AT SETBACK: 128.0'

NOTE:
 AREAS DELINEATED AS VISION TRIANGLE AREAS
 SHALL HAVE NO PLANTINGS OVER TWO (2) FEET
 IN HEIGHT.

TYPICAL VISION CORNER DETAIL

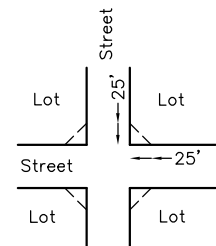

BSE1921\Final Plat\sales maps.dwg

LOT 42
 TERRAVESSA
 FITCHBURG LANDS, LLC

DATE: 08-05-2019
 PROJECT NO.: BSE1921

SCALE
 1"=60'

IF THIS BAR DOES NOT MEASURE 1"
 THEN DRAWING IS NOT TO SCALE

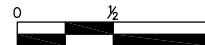

Burse
 surveying & engineering Inc.
 2801 International Lane, Suite 101
 Madison, WI 53704 608.250.9263
 Fax: 608.250.9266
 email: mburse@bse-inc.net
 www.bursesurveyengr.com

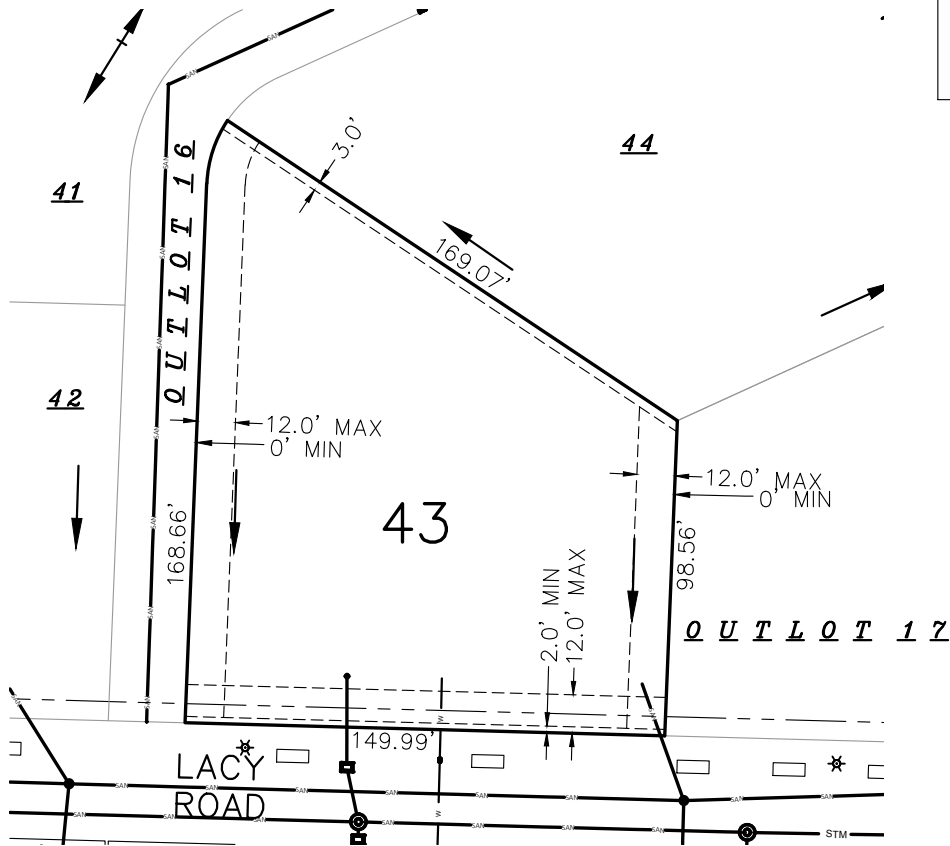

LEGEND	
	SURFACE DRAINAGE SWALE DIRECTION
	BUILDING SETBACK LINE
	WATER SERVICE (PROPOSED)
	SANITARY LATERAL (PROPOSED)
	6' ELECTRIC AND GAS LINES BELOW GRADE EASEMENT
	10' UTILITY EASEMENT
	STREET LIGHT

TRANSECT ZONE: T5
 LOT SQUARE FOOTAGE: 21,749
 BLDG. ENV. WIDTH AT SETBACK: 150.0'

BSE1921\Final Plat\sales maps.dwg

LOT 43
 TERRAVESSA
 FITCHBURG LANDS, LLC

DATE 12-13-2018	PROJECT NO. BSE1921
SCALE 1"=60'	
IF THIS BAR DOES NOT MEASURE 1" THEN DRAWING IS NOT TO SCALE	

Burse
 surveying & engineering LLC
 2801 International Lane, Suite 101
 Madison, WI 53704 G08.250.9263
 Fax: G08.250.9266
 email: mburse@bse-inc.net
 www.bursesurveyengr.com

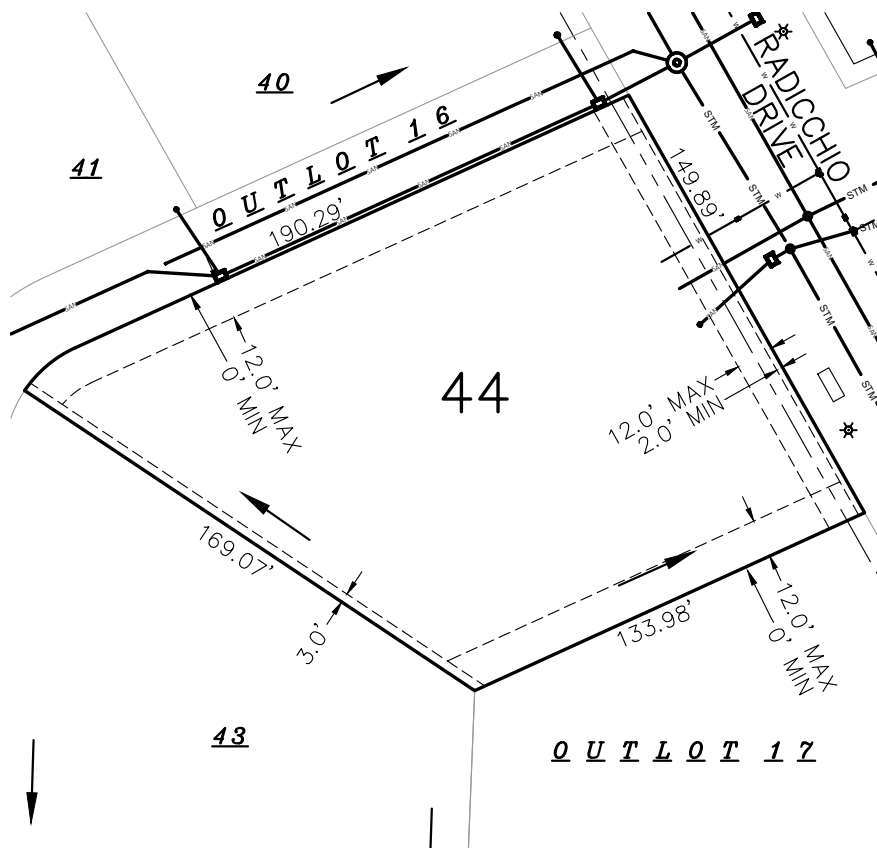

LEGEND

- SURFACE DRAINAGE SWALE DIRECTION
- BUILDING SETBACK LINE
- WATER SERVICE (PROPOSED)
- SANITARY LATERAL (PROPOSED)
- 6' ELECTRIC AND GAS LINES BELOW GRADE EASEMENT
- 10' UTILITY EASEMENT
- STREET LIGHT

TRANSECT ZONE: T5 LOT
 SQUARE FOOTAGE: 25,907 BLDG.
 ENV. WIDTH AT SETBACK:

BSE1921\Final Plat\sales maps.dwg

LOT 44
 TERRAVESSA
 FITCHBURG LANDS, LLC

DATE 02-20-2018	PROJECT NO. BSE1921
SCALE 1"=60'	
IF THIS BAR DOES NOT MEASURE 1" THEN DRAWING IS NOT TO SCALE	

Burse
 surveying & engineering LLC
 2801 International Lane, Suite 101
 Madison, WI 53704 608.250.9263
 Fax: 608.250.9266
 email: mburse@bse-inc.net
 www.bursesurveyengr.com

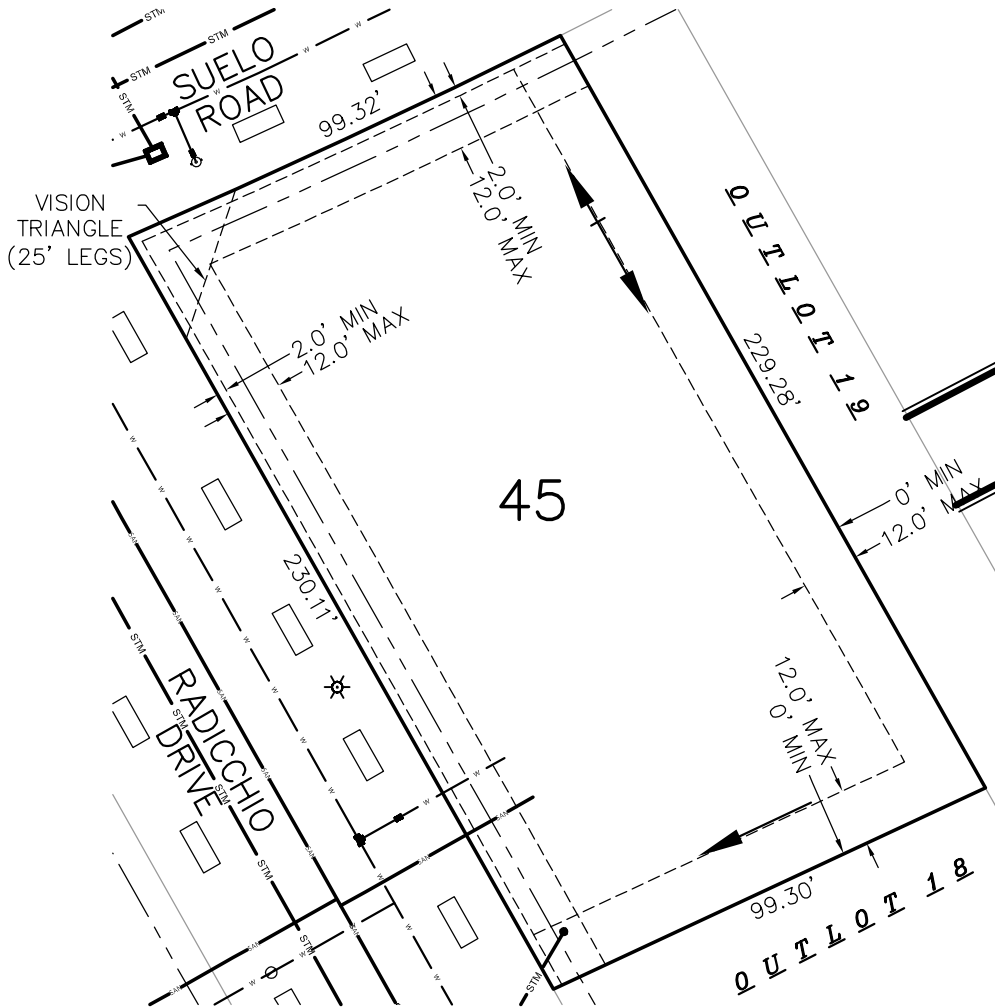

LEGEND

- SURFACE DRAINAGE SWALE DIRECTION
- BUILDING SETBACK LINE
- WATER SERVICE (PROPOSED)
- SANITARY LATERAL (PROPOSED)
- 6' ELECTRIC AND GAS LINES BELOW GRADE EASEMENT
- 10' UTILITY EASEMENT
- STREET LIGHT



TRANSECT ZONE: T5
 LOT SQUARE FOOTAGE: 17,778
 BLDG. ENV. WIDTH AT SETBACK: 97.3'

NOTE:
 AREAS DELINEATED AS VISION TRIANGLE AREAS
 SHALL HAVE NO PLANTINGS OVER TWO (2) FEET
 IN HEIGHT.

TYPICAL VISION CORNER DETAIL

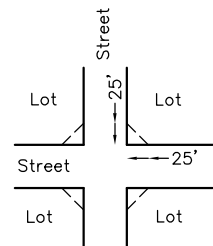

BSE1921\Final Plat\sales maps.dwg

LOT 45
 TERRAVESSA
 FITCHBURG LANDS, LLC

DATE: 12-13-2018 PROJECT NO.: BSE1921

SCALE
 1"=40'

IF THIS BAR DOES NOT MEASURE 1"
 THEN DRAWING IS NOT TO SCALE

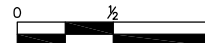

Burse
 surveying & engineering Inc.
 2801 International Lane, Suite 101
 Madison, WI 53704 608.250.9263
 Fax: 608.250.9266
 email: mburse@bse-inc.net
 www.bursesurveyengr.com

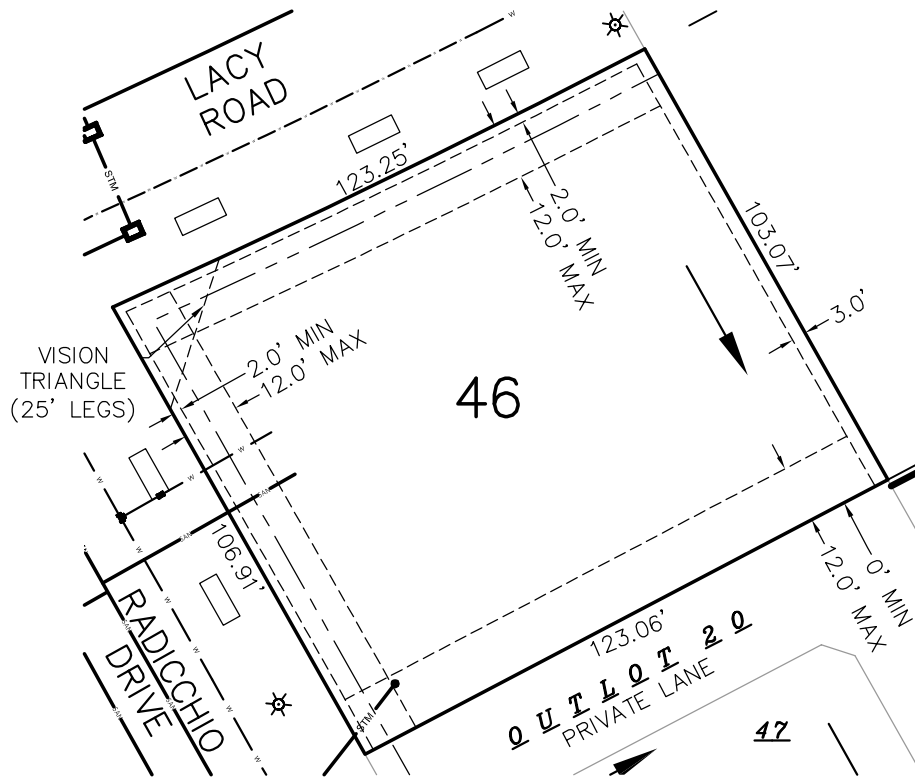

LEGEND

- SURFACE DRAINAGE SWALE DIRECTION
- BUILDING SETBACK LINE
- WATER SERVICE (PROPOSED)
- SANITARY LATERAL (PROPOSED)
- 6' ELECTRIC AND GAS LINES BELOW GRADE EASEMENT
- 10' UTILITY EASEMENT
- STREET LIGHT

TRANSECT ZONE: T5
 LOT SQUARE FOOTAGE: 12,843
 BLDG. ENV. WIDTH AT SETBACK: 104.9'

NOTE:
 AREAS DELINEATED AS VISION TRIANGLE AREAS
 SHALL HAVE NO PLANTINGS OVER TWO (2) FEET
 IN HEIGHT.

TYPICAL VISION CORNER DETAIL

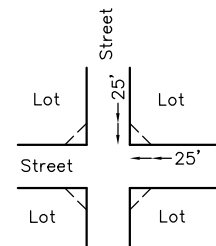

BSE1921\Final Plat\sales maps.dwg

LOT 46
 TERRAVESSA
 FITCHBURG LANDS, LLC

DATE: 08-05-2019
 PROJECT NO.: BSE1921

SCALE
 1"=40'

IF THIS BAR DOES NOT MEASURE 1"
 THEN DRAWING IS NOT TO SCALE

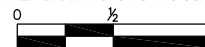

Burse
 surveying & engineering Inc.
 2801 International Lane, Suite 101
 Madison, WI 53704 608.250.9263
 Fax: 608.250.9266
 email: mburse@bse-inc.net
 www.bursesurveyengr.com

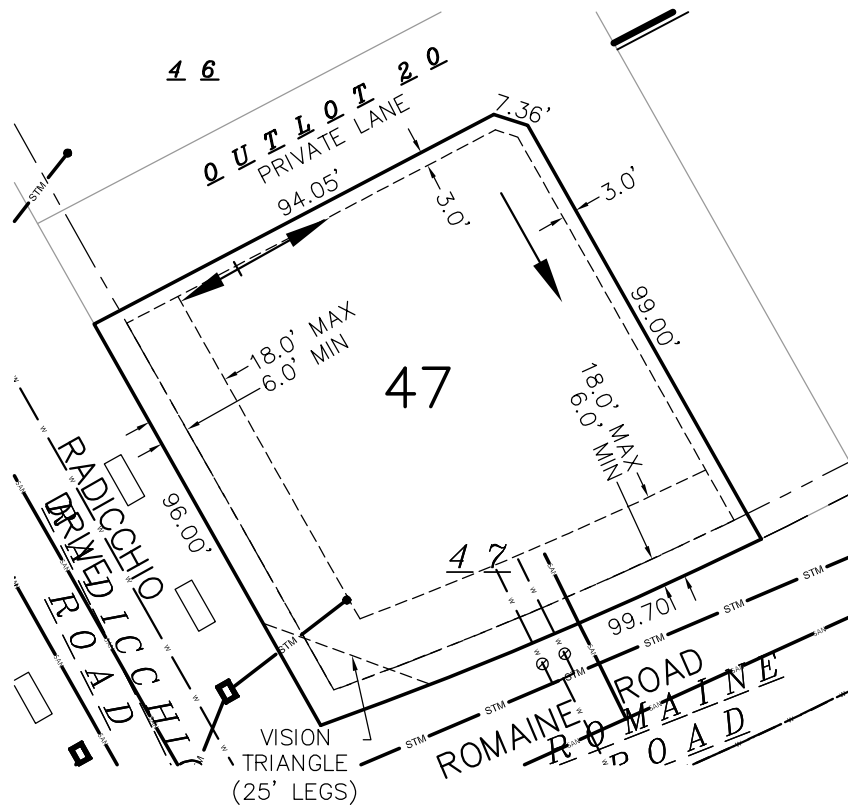

LEGEND

- SURFACE DRAINAGE SWALE DIRECTION
- BUILDING SETBACK LINE
- WATER SERVICE (PROPOSED)
- SANITARY LATERAL (PROPOSED)
- 6' ELECTRIC AND GAS LINES BELOW GRADE EASEMENT
- 10' UTILITY EASEMENT
- STREET LIGHT



TRANSECT ZONE: T4
 LOT SQUARE FOOTAGE: 9,994
 BLDG. ENV. WIDTH AT SETBACK: 90.7'

NOTE:
 AREAS DELINEATED AS VISION TRIANGLE AREAS
 SHALL HAVE NO PLANTINGS OVER TWO (2) FEET
 IN HEIGHT.

TYPICAL VISION CORNER DETAIL

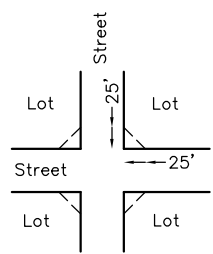

BSE1921\Final Plat\sales maps.dwg

LOT 47
 TERRAVESSA
 FITCHBURG LANDS, LLC

DATE 08-05-2019	PROJECT NO. BSE1921
SCALE 1"=40'	
IF THIS BAR DOES NOT MEASURE 1" THEN DRAWING IS NOT TO SCALE	

Burse
 surveying & engineering Inc.
 2801 International Lane, Suite 101
 Madison, WI 53704 608.250.9263
 Fax: 608.250.9266
 email: mburse@bse-inc.net
 www.bursesurveyengr.com

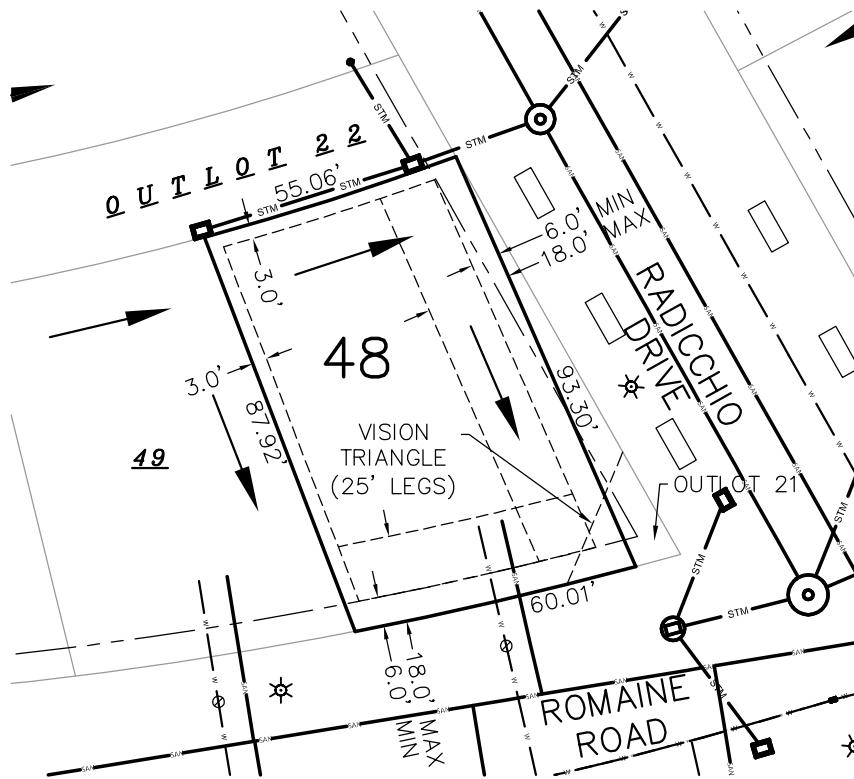

LEGEND

- SURFACE DRAINAGE SWALE DIRECTION
- BUILDING SETBACK LINE
- WATER SERVICE (PROPOSED)
- SANITARY LATERAL (PROPOSED)
- 6' ELECTRIC AND GAS LINES BELOW GRADE EASEMENT
- 10' UTILITY EASEMENT
- STREET LIGHT

TRANSECT ZONE: T4
 LOT SQUARE FOOTAGE: 5,164
 BLDG. ENV. WIDTH AT SETBACK: 51.0'

NOTE:
 AREAS DELINEATED AS VISION TRIANGLE AREAS
 SHALL HAVE NO PLANTINGS OVER TWO (2) FEET
 IN HEIGHT.

TYPICAL VISION CORNER DETAIL

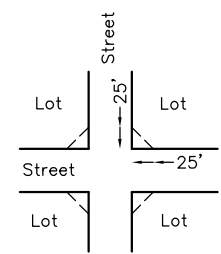

BSE1921\Final Plat\sales maps.dwg

LOT 48
 TERRAVESSA
 FITCHBURG LANDS, LLC

DATE 08-05-2019	PROJECT NO. BSE1921
SCALE 1"=40'	
IF THIS BAR DOES NOT MEASURE 1" THEN DRAWING IS NOT TO SCALE	

Burse
 surveying & engineering Inc.
 2801 International Lane, Suite 101
 Madison, WI 53704 608.250.9263
 Fax: 608.250.9266
 email: mburse@bse-inc.net
 www.bursesurveyengr.com

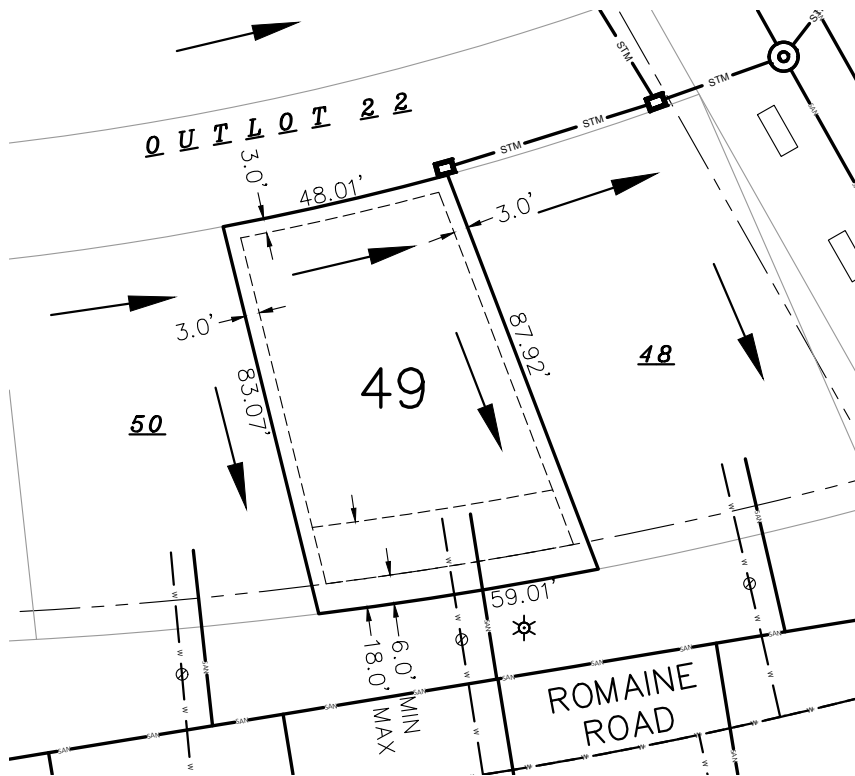

LEGEND

- SURFACE DRAINAGE SWALE DIRECTION
- BUILDING SETBACK LINE
- WATER SERVICE (PROPOSED)
- SANITARY LATERAL (PROPOSED)
- 6' ELECTRIC AND GAS LINES BELOW GRADE EASEMENT
- 10' UTILITY EASEMENT
- STREET LIGHT

TRANSECT ZONE: T4
 LOT SQUARE FOOTAGE: 4,536
 BLDG. ENV. WIDTH AT SETBACK: 53.0'

BSE1921\Final Plat\sales maps.dwg

LOT 49
 TERRAVESSA
 FITCHBURG LANDS, LLC

DATE 12-13-2018	PROJECT NO. BSE1921
SCALE 1" = 40'	
IF THIS BAR DOES NOT MEASURE 1" THEN DRAWING IS NOT TO SCALE	

Burse
 surveying & engineering LLC
 2801 International Lane, Suite 101
 Madison, WI 53704 608.250.9263
 Fax: 608.250.9266
 email: mburse@bse-inc.net
 www.bursesurveyengr.com

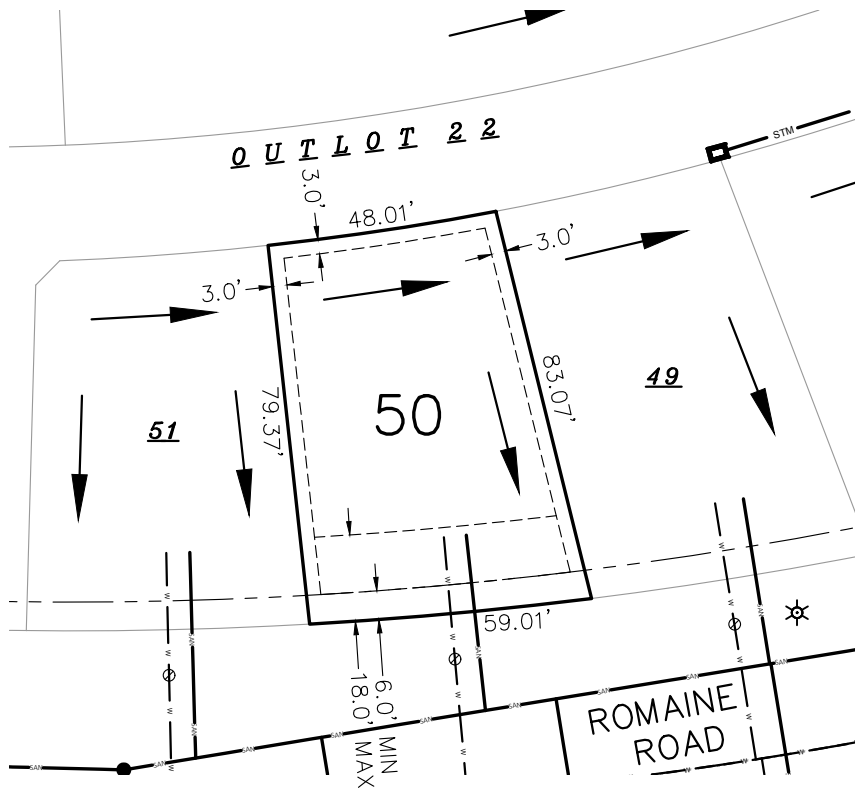

LEGEND

- SURFACE DRAINAGE SWALE DIRECTION
- BUILDING SETBACK LINE
- WATER SERVICE (PROPOSED)
- SANITARY LATERAL (PROPOSED)
- 6' ELECTRIC AND GAS LINES BELOW GRADE EASEMENT
- 10' UTILITY EASEMENT
- STREET LIGHT

TRANSECT ZONE: T4
 LOT SQUARE FOOTAGE: 4,330
 BLDG. ENV. WIDTH AT SETBACK: 53.0'

BSE1921\Final Plat\sales maps.dwg

LOT 50
 TERRAVESSA
 FITCHBURG LANDS, LLC

DATE 12-13-2018	PROJECT NO. BSE1921
SCALE 1" = 40'	
IF THIS BAR DOES NOT MEASURE 1" THEN DRAWING IS NOT TO SCALE	

Burse
 surveying & engineering LLC
 2801 International Lane, Suite 101
 Madison, WI 53704 608.250.9263
 Fax: 608.250.9266
 email: mburse@bse-inc.net
 www.bursesurveyengr.com

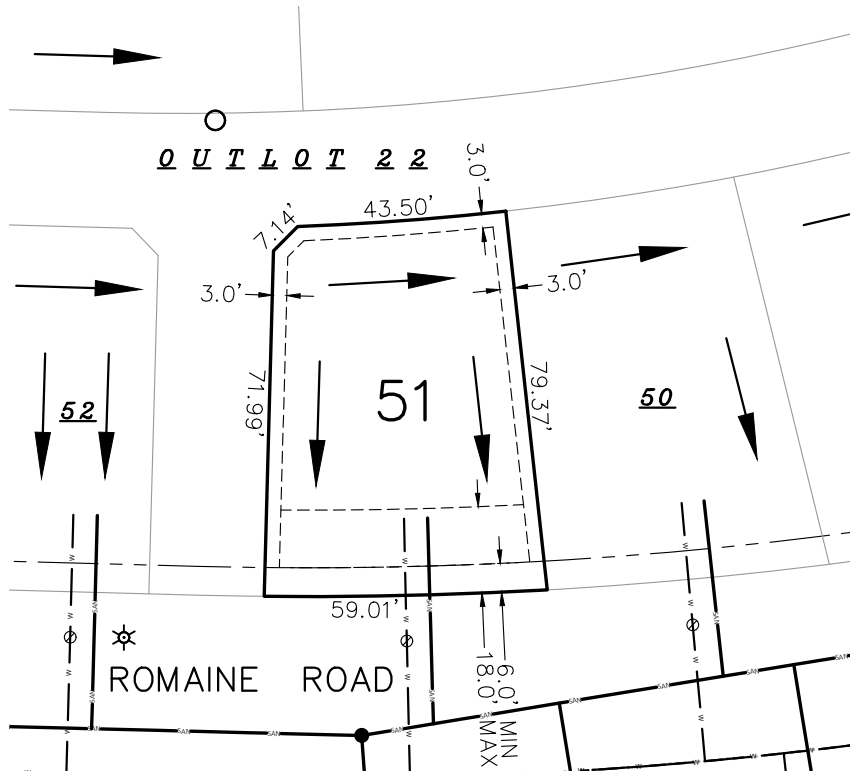

LEGEND

- SURFACE DRAINAGE SWALE DIRECTION
- BUILDING SETBACK LINE
- WATER SERVICE (PROPOSED)
- SANITARY LATERAL (PROPOSED)
- 6' ELECTRIC AND GAS LINES BELOW GRADE EASEMENT
- 10' UTILITY EASEMENT
- STREET LIGHT

TRANSECT ZONE: T4
 LOT SQUARE FOOTAGE: 4,176
 BLDG. ENV. WIDTH AT SETBACK: 53.0'



LOT 51
 TERRAVESSA
 FITCHBURG LANDS, LLC

DATE 12-13-2018	PROJECT NO. BSE1921
SCALE 1" = 40'	
IF THIS BAR DOES NOT MEASURE 1" THEN DRAWING IS NOT TO SCALE	

Burse
 surveying & engineering LLC
 2801 International Lane, Suite 101
 Madison, WI 53704 608.250.9263
 Fax: 608.250.9266
 email: mburse@bse-inc.net
 www.bursesurveyengr.com

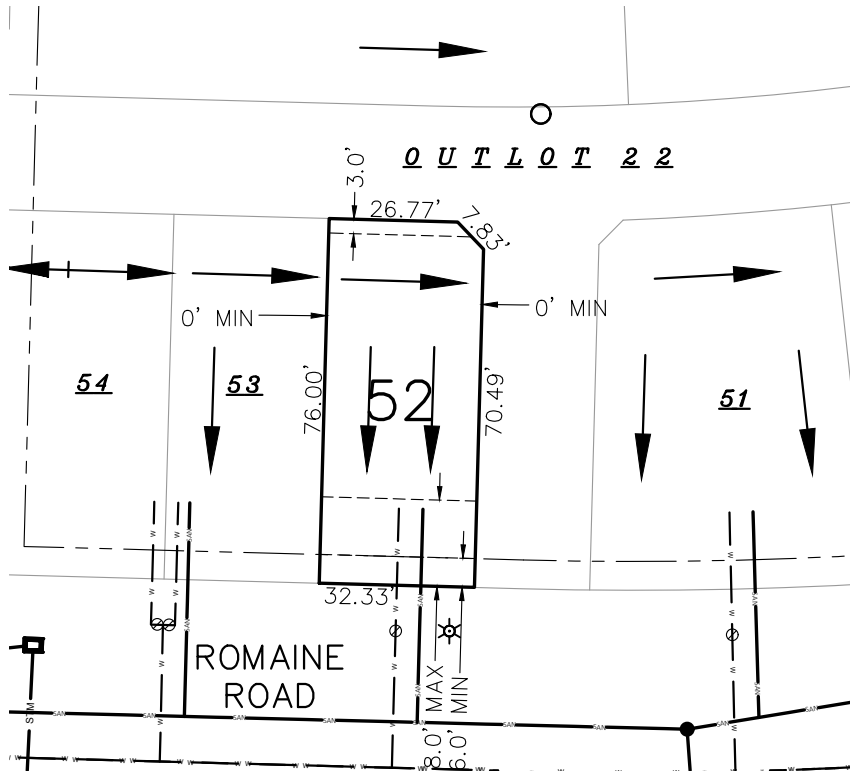

LEGEND

- SURFACE DRAINAGE SWALE DIRECTION
- BUILDING SETBACK LINE
- WATER SERVICE (PROPOSED)
- SANITARY LATERAL (PROPOSED)
- 6' ELECTRIC AND GAS LINES BELOW GRADE EASEMENT
- 10' UTILITY EASEMENT
- STREET LIGHT

TRANSECT ZONE: T4
 LOT SQUARE FOOTAGE: 2,442
 BLDG. ENV. WIDTH AT SETBACK: 32.3'

BSE1921\Final Plat\sales maps.dwg

LOT 52
 TERRAVESSA
 FITCHBURG LANDS, LLC

DATE 12-13-2018	PROJECT NO. BSE1921
SCALE 1" = 40'	
IF THIS BAR DOES NOT MEASURE 1" THEN DRAWING IS NOT TO SCALE	

Burse
 surveying & engineering LLC
 2801 International Lane, Suite 101
 Madison, WI 53704 608.250.9263
 Fax: 608.250.9266
 email: mburse@bse-inc.net
 www.bursesurveyengr.com

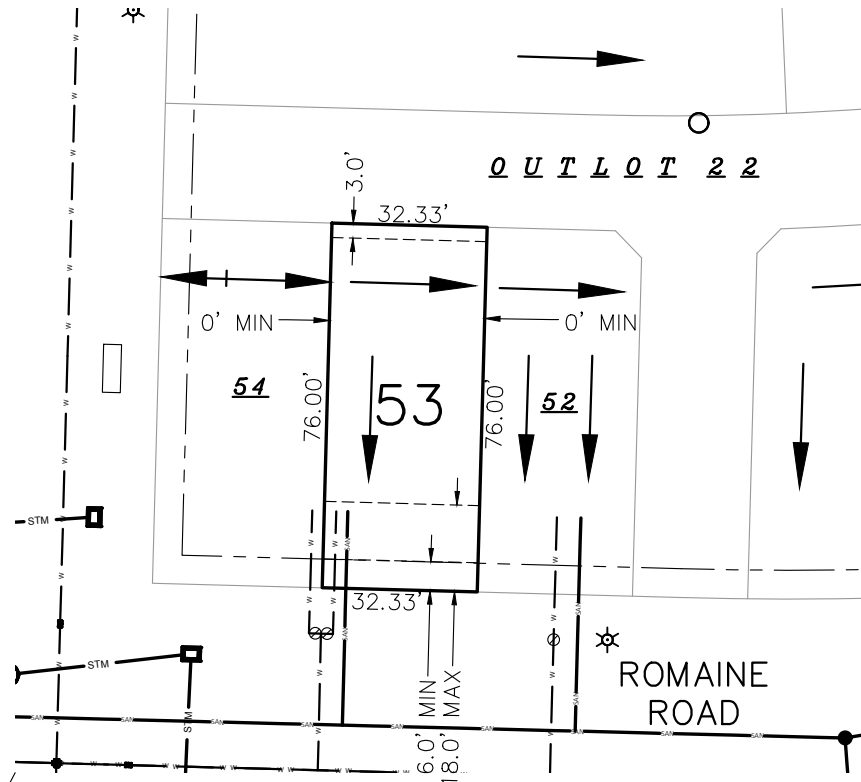

LEGEND

- SURFACE DRAINAGE SWALE DIRECTION
- BUILDING SETBACK LINE
- WATER SERVICE (PROPOSED)
- SANITARY LATERAL (PROPOSED)
- 6' ELECTRIC AND GAS LINES BELOW GRADE EASEMENT
- 10' UTILITY EASEMENT
- STREET LIGHT

TRANSECT ZONE: T4
 LOT SQUARE FOOTAGE: 2,457
 BLDG. ENV. WIDTH AT SETBACK: 32.3'

BSE1921\Final Plat\sales maps.dwg

LOT 53
 TERRAVESSA
 FITCHBURG LANDS, LLC

DATE 12-13-2018	PROJECT NO. BSE1921
SCALE 1" = 40'	
IF THIS BAR DOES NOT MEASURE 1" THEN DRAWING IS NOT TO SCALE	

Burse
 surveying & engineering LLC
 2801 International Lane, Suite 101
 Madison, WI 53704 G08.250.9263
 Fax: G08.250.9266
 email: mburse@bse-inc.net
 www.bursesurveyengr.com

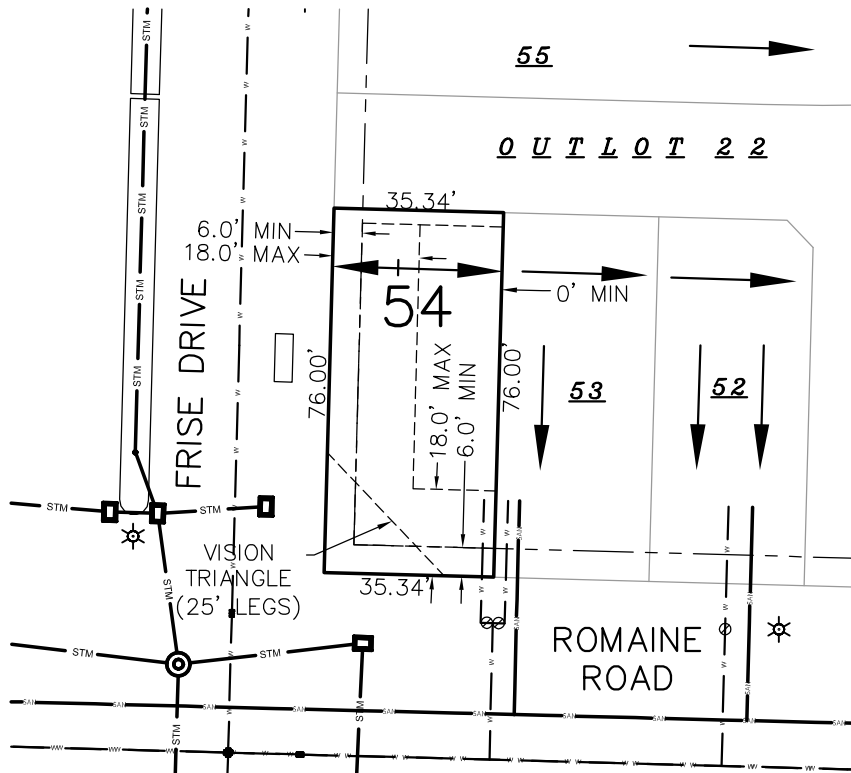

LEGEND

- SURFACE DRAINAGE SWALE DIRECTION
- BUILDING SETBACK LINE
- WATER SERVICE (PROPOSED)
- SANITARY LATERAL (PROPOSED)
- 6' ELECTRIC AND GAS LINES BELOW GRADE EASEMENT
- 10' UTILITY EASEMENT
- STREET LIGHT



TRANSECT ZONE: T4
 LOT SQUARE FOOTAGE: 2,685
 BLDG. ENV. WIDTH AT SETBACK: 35.3'

NOTE:
 AREAS DELINEATED AS VISION TRIANGLE AREAS
 SHALL HAVE NO PLANTINGS OVER TWO (2) FEET
 IN HEIGHT.

TYPICAL VISION CORNER DETAIL

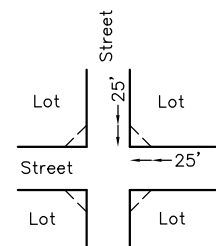

BSE1921\Final Plat\sales maps.dwg

LOT 54
 TERRAVESSA
 FITCHBURG LANDS, LLC

DATE: 08-05-2019 PROJECT NO.: BSE1921

SCALE: 1"=40'

IF THIS BAR DOES NOT MEASURE 1" THEN DRAWING IS NOT TO SCALE

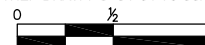

Burse
 surveying & engineering Inc.
 2801 International Lane, Suite 101
 Madison, WI 53704 608.250.9263
 Fax: 608.250.9266
 email: mburse@bse-inc.net
 www.bursesurveyengr.com

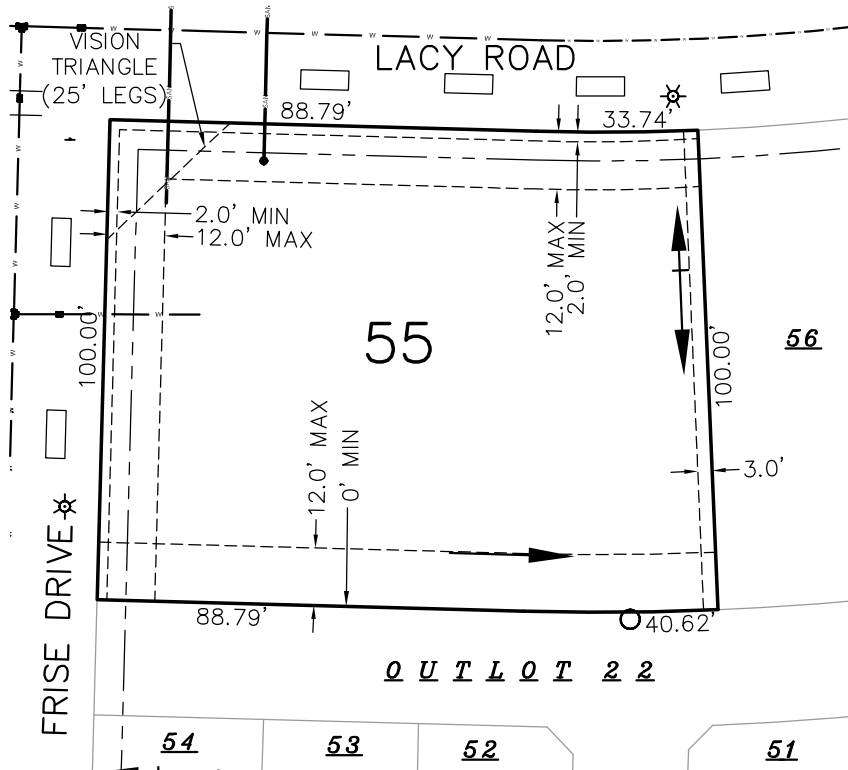

LEGEND

- SURFACE DRAINAGE SWALE DIRECTION
- BUILDING SETBACK LINE
- WATER SERVICE (PROPOSED)
- SANITARY LATERAL (PROPOSED)
- 6' ELECTRIC AND GAS LINES BELOW GRADE EASEMENT
- 10' UTILITY EASEMENT
- STREET LIGHT



TRANSECT ZONE: T5
 LOT SQUARE FOOTAGE: 12,596
 BLDG. ENV. WIDTH AT SETBACK: 98.0'

NOTE:
 AREAS DELINEATED AS VISION TRIANGLE AREAS
 SHALL HAVE NO PLANTINGS OVER TWO (2) FEET
 IN HEIGHT.

TYPICAL VISION CORNER DETAIL

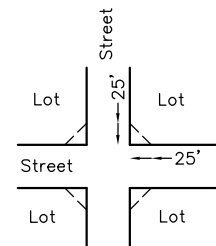

BSE1921\Final Plat\sales maps.dwg

LOT 55
 TERRAVESSA
 FITCHBURG LANDS, LLC

DATE 08-05-2019	PROJECT NO. BSE1921
SCALE 1"=40'	
IF THIS BAR DOES NOT MEASURE 1" THEN DRAWING IS NOT TO SCALE	

Burse
 surveying & engineering Inc.
 2801 International Lane, Suite 101
 Madison, WI 53704 608.250.9263
 Fax: 608.250.9266
 email: mburse@bse-inc.net
 www.bursesurveyengr.com

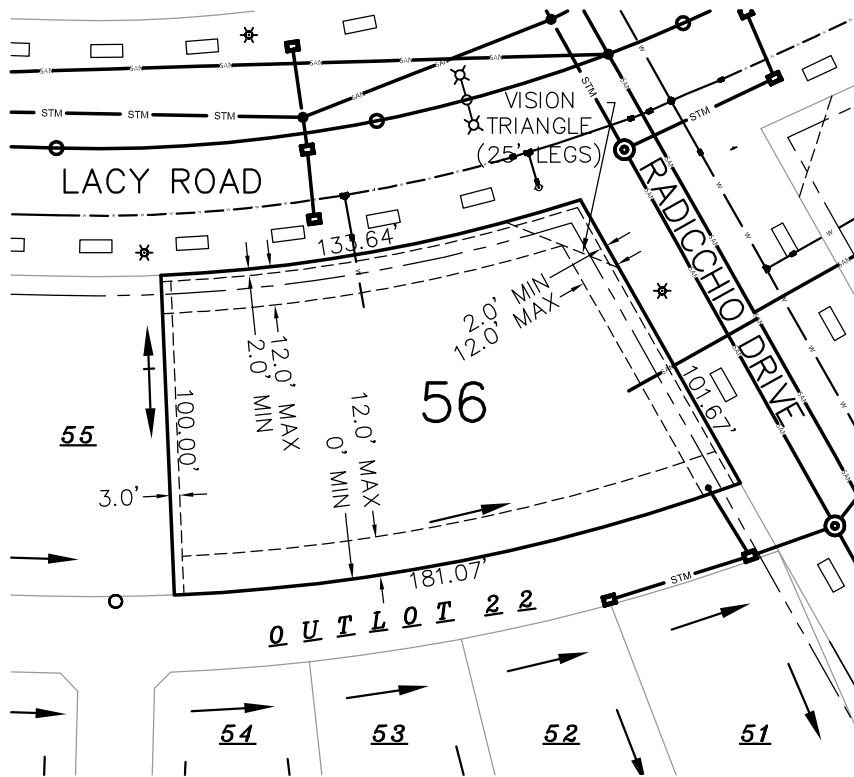

LEGEND

- SURFACE DRAINAGE SWALE DIRECTION
- BUILDING SETBACK LINE
- WATER SERVICE (PROPOSED)
- SANITARY LATERAL (PROPOSED)
- 6' ELECTRIC AND GAS LINES BELOW GRADE EASEMENT
- 10' UTILITY EASEMENT
- STREET LIGHT



TRANSECT ZONE: T5
 LOT SQUARE FOOTAGE: 15,736
 BLDG. ENV. WIDTH AT SETBACK: 99.7'

NOTE:
 AREAS DELINEATED AS VISION TRIANGLE AREAS
 SHALL HAVE NO PLANTINGS OVER TWO (2) FEET
 IN HEIGHT.

TYPICAL VISION CORNER DETAIL

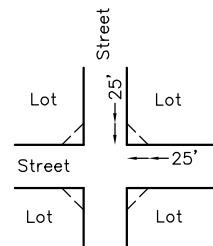

BSE1921\Final Plat\sales maps.dwg

LOT 56
 TERRAVESSA
 FITCHBURG LANDS, LLC

DATE 08-05-2019	PROJECT NO. BSE1921
SCALE 1"=60'	
IF THIS BAR DOES NOT MEASURE 1" THEN DRAWING IS NOT TO SCALE	

Burse
 surveying & engineering Inc.
 2801 International Lane, Suite 101
 Madison, WI 53704 608.250.9263
 Fax: 608.250.9266
 email: mburse@bse-inc.net
 www.bursesurveyengr.com

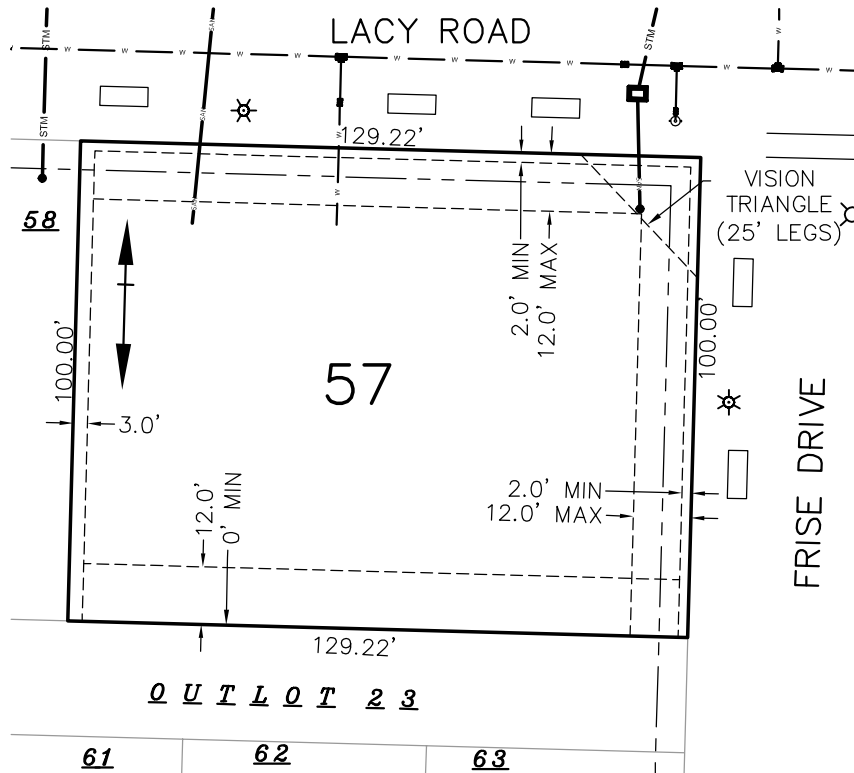

LEGEND

- SURFACE DRAINAGE SWALE DIRECTION
- BUILDING SETBACK LINE
- WATER SERVICE (PROPOSED)
- SANITARY LATERAL (PROPOSED)
- 6' ELECTRIC AND GAS LINES BELOW GRADE EASEMENT
- 10' UTILITY EASEMENT
- STREET LIGHT

TRANSECT ZONE: T5
 LOT SQUARE FOOTAGE: 12,922
 BLDG. ENV. WIDTH AT SETBACK: 98.0'

NOTE:
 AREAS DELINEATED AS VISION TRIANGLE AREAS
 SHALL HAVE NO PLANTINGS OVER TWO (2) FEET
 IN HEIGHT.

TYPICAL VISION CORNER DETAIL

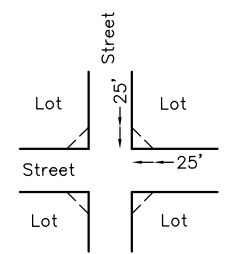

BSE1921\Final Plat\sales maps.dwg

LOT 57
 TERRAVESSA
 FITCHBURG LANDS, LLC

DATE 12-13-2018	PROJECT NO. BSE1921
SCALE 1"=40'	
IF THIS BAR DOES NOT MEASURE 1" THEN DRAWING IS NOT TO SCALE	

Burse
 surveying & engineering Inc.

2801 International Lane, Suite 101
 Madison, WI 53704 608.250.9263
 Fax: 608.250.9266
 email: mburse@bse-inc.net
 www.bursesurveyengr.com

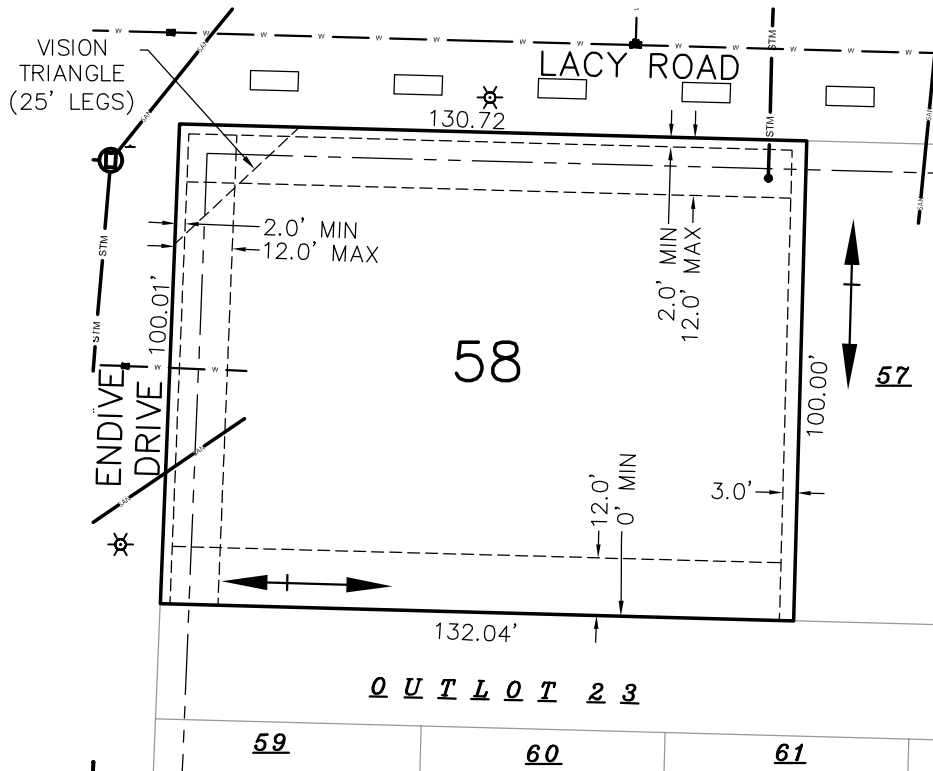

LEGEND

- SURFACE DRAINAGE SWALE DIRECTION
- BUILDING SETBACK LINE
- WATER SERVICE (PROPOSED)
- SANITARY LATERAL (PROPOSED)
- 6' ELECTRIC AND GAS LINES BELOW GRADE EASEMENT
- 10' UTILITY EASEMENT
- STREET LIGHT

TRANSECT ZONE: T5
 LOT SQUARE FOOTAGE: 13,138
 BLDG. ENV. WIDTH AT SETBACK: 98.0'

NOTE:
 AREAS DELINEATED AS VISION TRIANGLE AREAS
 SHALL HAVE NO PLANTINGS OVER TWO (2) FEET
 IN HEIGHT.

TYPICAL VISION CORNER DETAIL

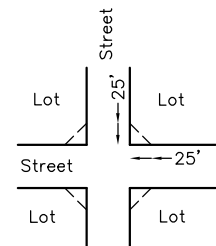

BSE1921\Final Plat\sales maps.dwg

LOT 58
 TERRAVESSA
 FITCHBURG LANDS, LLC

DATE 08-05-2019	PROJECT NO. BSE1921
SCALE 1"=40'	
IF THIS BAR DOES NOT MEASURE 1" THEN DRAWING IS NOT TO SCALE	

Burse
 surveying & engineering Inc.
 2801 International Lane, Suite 101
 Madison, WI 53704 608.250.9263
 Fax: 608.250.9266
 email: mburse@bse-inc.net
 www.bursesurveyengr.com

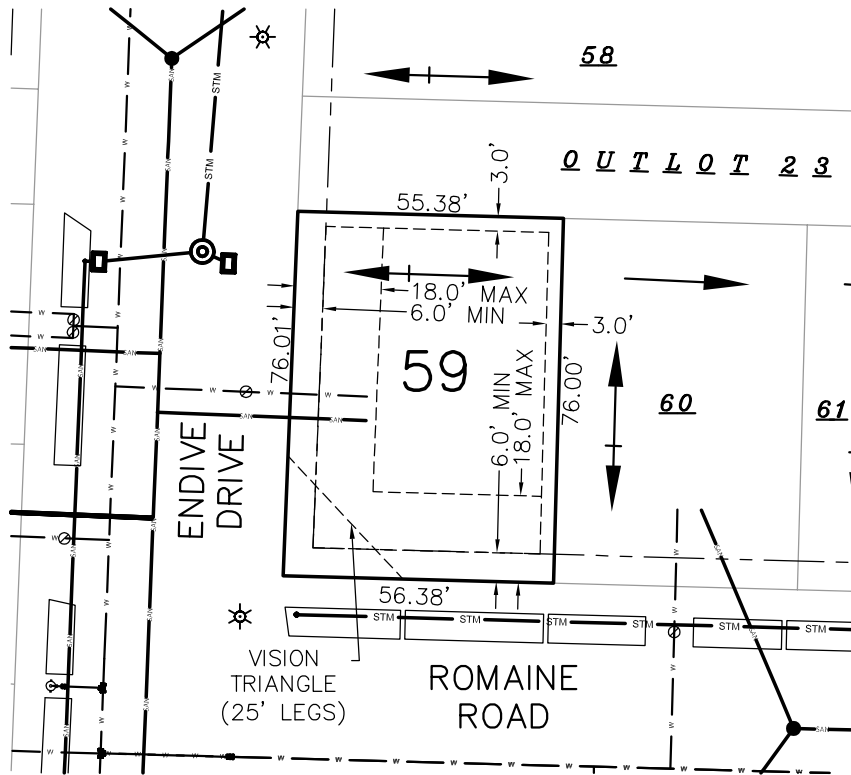

LEGEND

- SURFACE DRAINAGE SWALE DIRECTION
- BUILDING SETBACK LINE
- WATER SERVICE (PROPOSED)
- SANITARY LATERAL (PROPOSED)
- 6' ELECTRIC AND GAS LINES BELOW GRADE EASEMENT
- 10' UTILITY EASEMENT
- STREET LIGHT

TRANSECT ZONE: T4
 LOT SQUARE FOOTAGE: 4,247
 BLDG. ENV. WIDTH AT SETBACK: 47.4'

NOTE:
 AREAS DELINEATED AS VISION TRIANGLE AREAS
 SHALL HAVE NO PLANTINGS OVER TWO (2) FEET
 IN HEIGHT.

TYPICAL VISION CORNER DETAIL

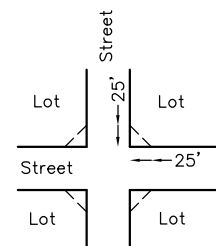

BSE1921\Final Plat\sales maps.dwg

LOT 59
 TERRAVESSA
 FITCHBURG LANDS, LLC

DATE: 08-05-2019
 PROJECT NO.: BSE1921

SCALE
 1"=40'

IF THIS BAR DOES NOT MEASURE 1"
 THEN DRAWING IS NOT TO SCALE

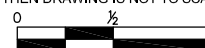

Burse
 surveying & engineering Inc.
 2801 International Lane, Suite 101
 Madison, WI 53704 608.250.9263
 Fax: 608.250.9266
 email: mburse@bse-inc.net
 www.bursesurveyengr.com

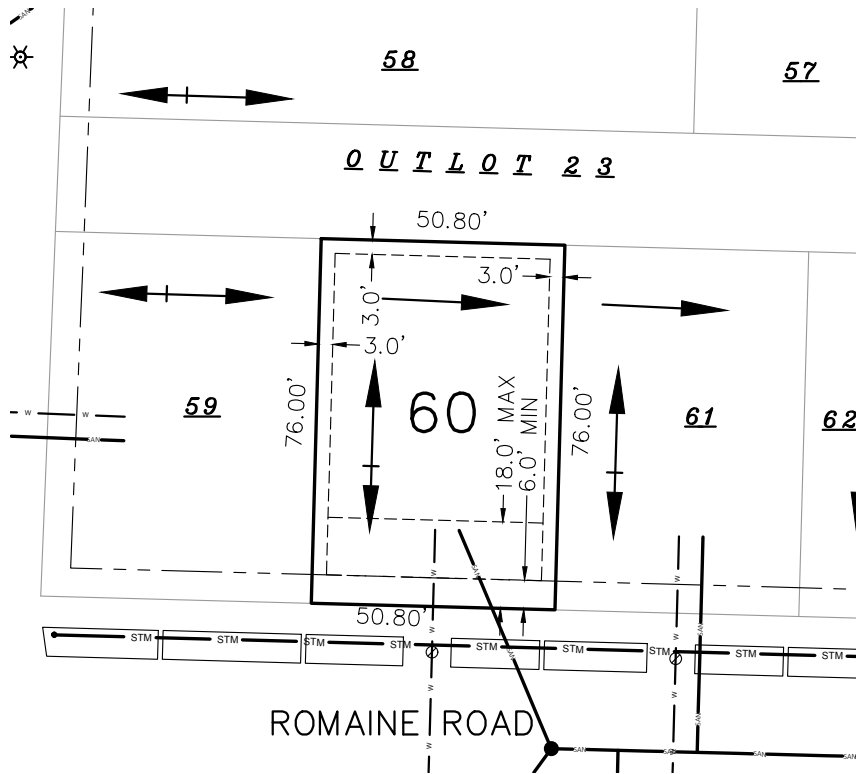

LEGEND

- SURFACE DRAINAGE SWALE DIRECTION
- BUILDING SETBACK LINE
- WATER SERVICE (PROPOSED)
- SANITARY LATERAL (PROPOSED)
- 6' ELECTRIC AND GAS LINES BELOW GRADE EASEMENT
- 10' UTILITY EASEMENT
- STREET LIGHT

TRANSECT ZONE: T4
 LOT SQUARE FOOTAGE: 3,861
 BLDG. ENV. WIDTH AT SETBACK: 44.8'

BSE1921\Final Plat\sales maps.dwg

LOT 60
 TERRAVESSA
 FITCHBURG LANDS, LLC

DATE 12-13-2018	PROJECT NO. BSE1921
SCALE 1" = 40'	
IF THIS BAR DOES NOT MEASURE 1" THEN DRAWING IS NOT TO SCALE	

Burse
 surveying & engineering LLC
 2801 International Lane, Suite 101
 Madison, WI 53704 608.250.9263
 Fax: 608.250.9266
 email: mburse@bse-inc.net
 www.bursesurveyengr.com

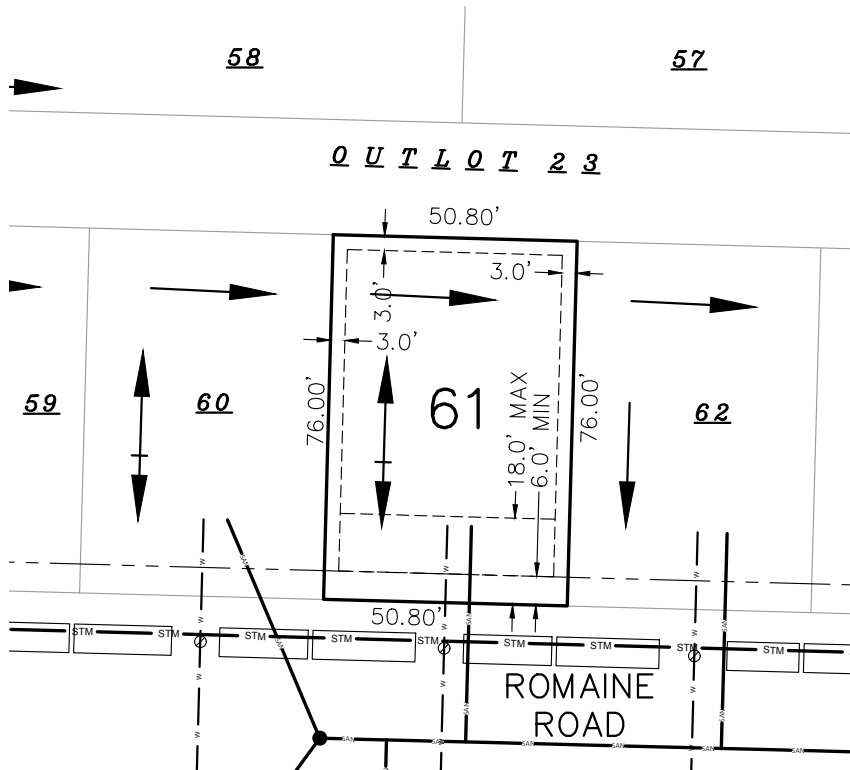

LEGEND

- SURFACE DRAINAGE SWALE DIRECTION
- BUILDING SETBACK LINE
- WATER SERVICE (PROPOSED)
- SANITARY LATERAL (PROPOSED)
- 6' ELECTRIC AND GAS LINES BELOW GRADE EASEMENT
- 10' UTILITY EASEMENT
- STREET LIGHT

TRANSECT ZONE: T4
 LOT SQUARE FOOTAGE: 3,861
 BLDG. ENV. WIDTH AT SETBACK: 44.8'

BSE1921\Final Plat\sales maps.dwg

LOT 61
 TERRAVESSA
 FITCHBURG LANDS, LLC

DATE 12-13-2018	PROJECT NO. BSE1921
SCALE 1" = 40'	
IF THIS BAR DOES NOT MEASURE 1" THEN DRAWING IS NOT TO SCALE	

Burse
 surveying & engineering LLC
 2801 International Lane, Suite 101
 Madison, WI 53704 608.250.9263
 Fax: 608.250.9266
 email: mburse@bse-inc.net
 www.bursesurveyengr.com

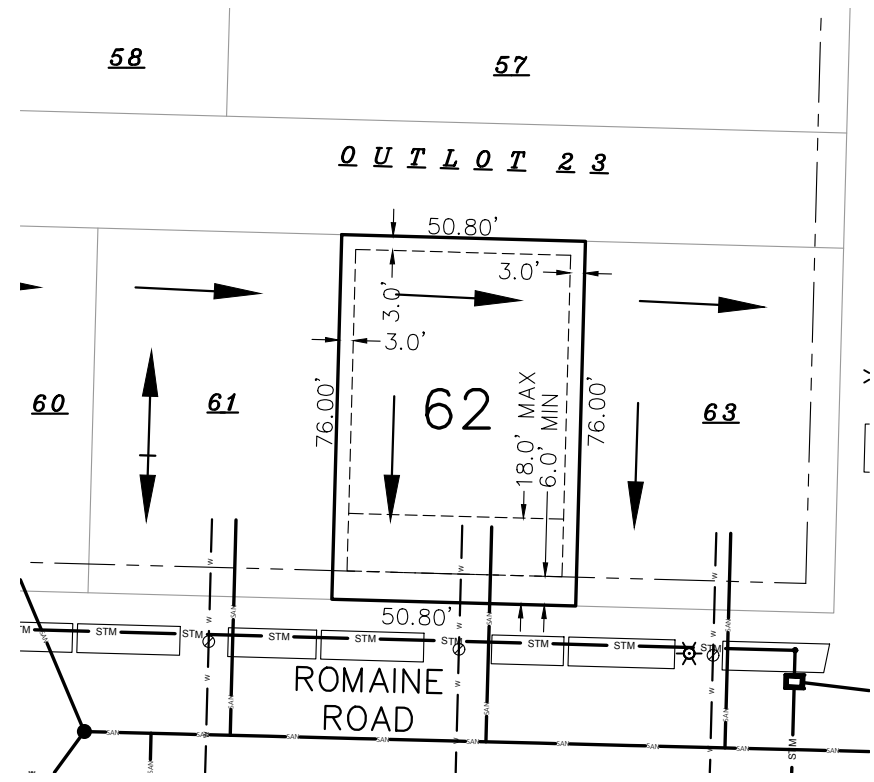

LEGEND

- SURFACE DRAINAGE SWALE DIRECTION
- BUILDING SETBACK LINE
- WATER SERVICE (PROPOSED)
- SANITARY LATERAL (PROPOSED)
- 6' ELECTRIC AND GAS LINES BELOW GRADE EASEMENT
- 10' UTILITY EASEMENT
- STREET LIGHT

TRANSECT ZONE: T4
 LOT SQUARE FOOTAGE: 3,861
 BLDG. ENV. WIDTH AT SETBACK: 44.8'

BSE1921\Final Plat\sales maps.dwg

LOT 62
 TERRAVESSA
 FITCHBURG LANDS, LLC

DATE 12-13-2018	PROJECT NO. BSE1921
SCALE 1" = 40'	
IF THIS BAR DOES NOT MEASURE 1" THEN DRAWING IS NOT TO SCALE	

Burse
 surveying & engineering LLC

2801 International Lane, Suite 101
 Madison, WI 53704 608.250.9263
 Fax: 608.250.9266
 email: mburse@bse-inc.net
 www.bursesurveyengr.com

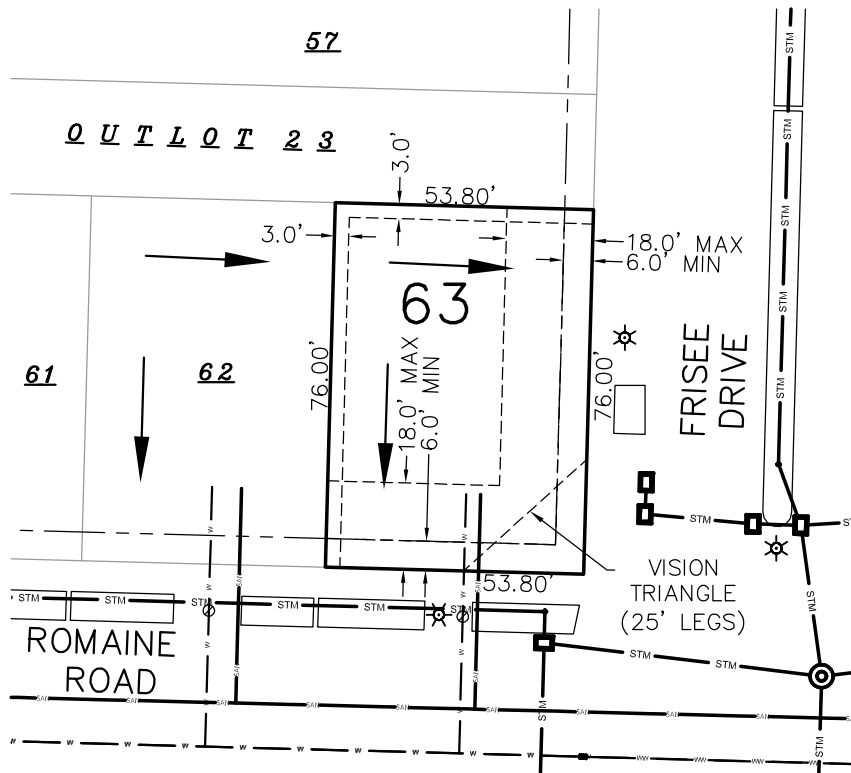

LEGEND

- SURFACE DRAINAGE SWALE DIRECTION
- BUILDING SETBACK LINE
- WATER SERVICE (PROPOSED)
- SANITARY LATERAL (PROPOSED)
- 6' ELECTRIC AND GAS LINES BELOW GRADE EASEMENT
- 10' UTILITY EASEMENT
- STREET LIGHT



TRANSECT ZONE: T4
 LOT SQUARE FOOTAGE: 4,089
 BLDG. ENV. WIDTH AT SETBACK: 44.8'

NOTE:
 AREAS DELINEATED AS VISION TRIANGLE AREAS
 SHALL HAVE NO PLANTINGS OVER TWO (2) FEET
 IN HEIGHT.

TYPICAL VISION CORNER DETAIL

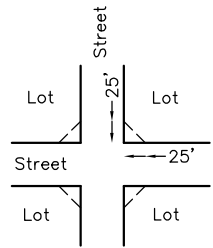

BSE1921\Final Plat\sales maps.dwg

LOT 63
 TERRAVESSA
 FITCHBURG LANDS, LLC

DATE 08-05-2019	PROJECT NO. BSE1921
SCALE 1"=40'	
IF THIS BAR DOES NOT MEASURE 1" THEN DRAWING IS NOT TO SCALE	

Burse
 surveying & engineering Inc.
 2801 International Lane, Suite 101
 Madison, WI 53704 608.250.9263
 Fax: 608.250.9266
 email: mburse@bse-inc.net
 www.bursesurveyengr.com

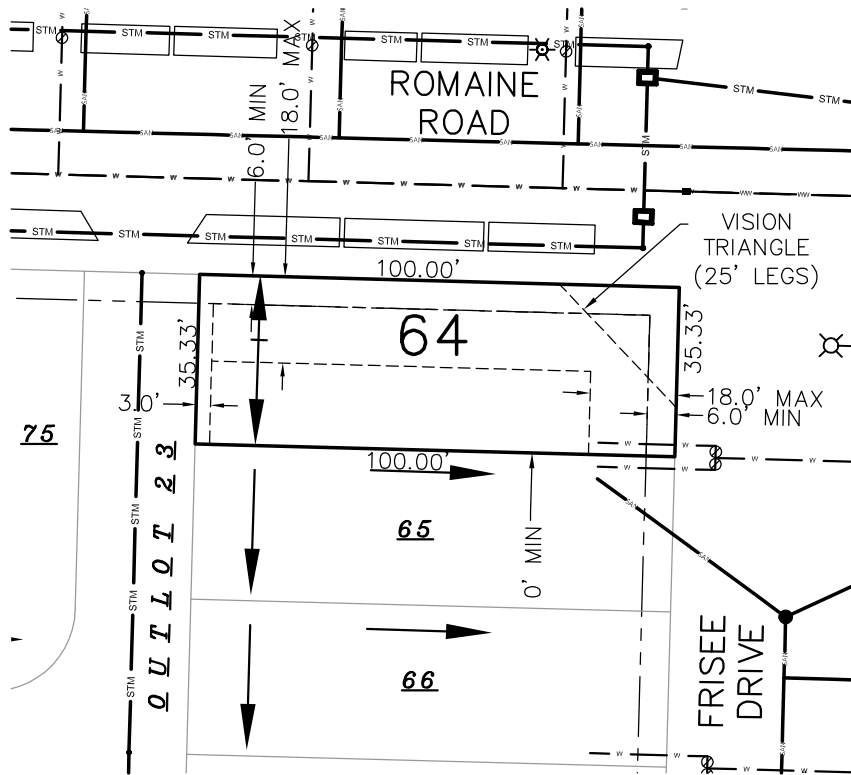

LEGEND

- ← SURFACE DRAINAGE SWALE DIRECTION
- - - - BUILDING SETBACK LINE
- W — WATER SERVICE (PROPOSED)
- SAN — SANITARY LATERAL (PROPOSED)
- - - - 6' ELECTRIC AND GAS LINES BELOW GRADE EASEMENT
- - - - 10' UTILITY EASEMENT
- ☼ STREET LIGHT



TRANSECT ZONE: T4
 LOT SQUARE FOOTAGE: 3,533
 BLDG. ENV. WIDTH AT SETBACK: 29.3'

NOTE:
 AREAS DELINEATED AS VISION TRIANGLE AREAS
 SHALL HAVE NO PLANTINGS OVER TWO (2) FEET
 IN HEIGHT.

TYPICAL VISION CORNER DETAIL

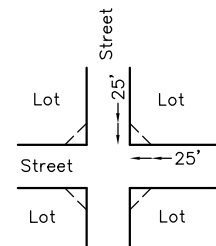

BSE1921\Final Plat\sales maps.dwg

LOT 64
 TERRAVESSA
 FITCHBURG LANDS, LLC

DATE: 08-05-2019
 PROJECT NO.: BSE1921

SCALE
 1"=40'

IF THIS BAR DOES NOT MEASURE 1"
 THEN DRAWING IS NOT TO SCALE

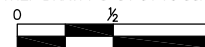

Burse
 surveying & engineering Inc.
 2801 International Lane, Suite 101
 Madison, WI 53704 608.250.9263
 Fax: 608.250.9266
 email: mburse@bse-inc.net
 www.bursesurveyengr.com

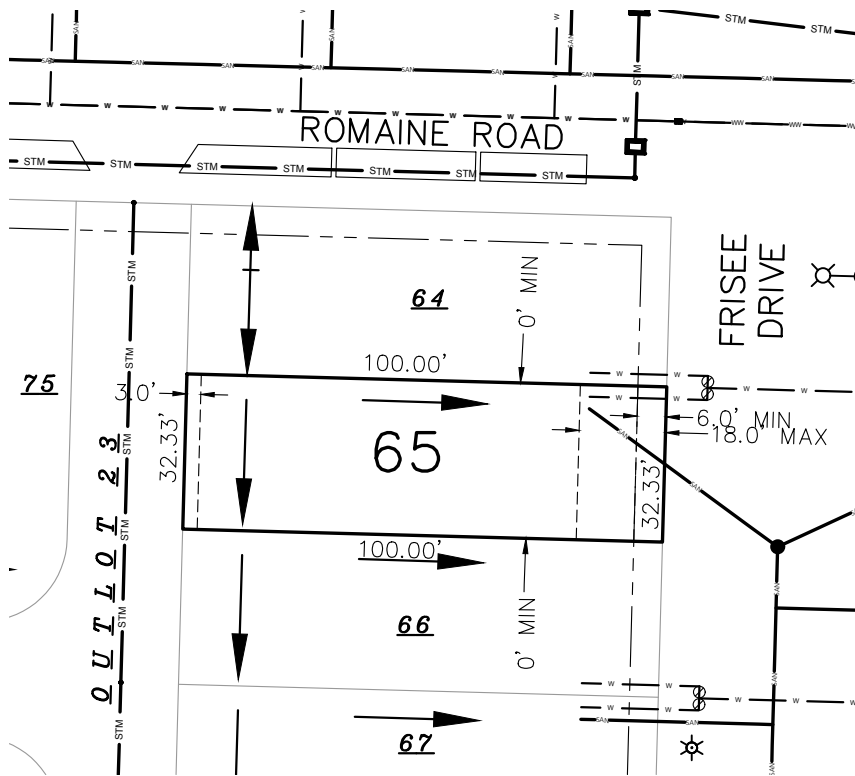

LEGEND

- SURFACE DRAINAGE SWALE DIRECTION
- BUILDING SETBACK LINE
- WATER SERVICE (PROPOSED)
- SANITARY LATERAL (PROPOSED)
- 6' ELECTRIC AND GAS LINES BELOW GRADE EASEMENT
- 10' UTILITY EASEMENT
- STREET LIGHT

TRANSECT ZONE: T4
 LOT SQUARE FOOTAGE: 3,233
 BLDG. ENV. WIDTH AT SETBACK: 32.33'

BSE1921\Final Plat\sales maps.dwg

LOT 65
 TERRAVESSA
 FITCHBURG LANDS, LLC

DATE 02-20-2018	PROJECT NO. BSE1921
SCALE 1" = 40'	
IF THIS BAR DOES NOT MEASURE 1" THEN DRAWING IS NOT TO SCALE	

Burse
 surveying & engineering LLC
 2801 International Lane, Suite 101
 Madison, WI 53704 608.250.9263
 Fax: 608.250.9266
 email: mburse@bse-inc.net
 www.bursesurveyengr.com

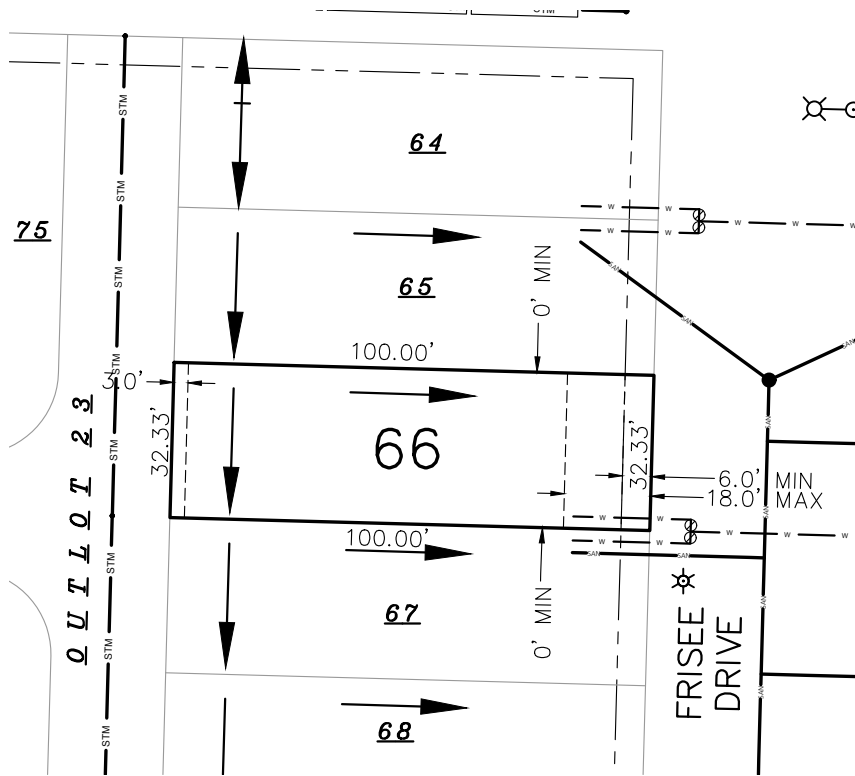

LEGEND

- SURFACE DRAINAGE SWALE DIRECTION
- BUILDING SETBACK LINE
- WATER SERVICE (PROPOSED)
- SANITARY LATERAL (PROPOSED)
- 6' ELECTRIC AND GAS LINES BELOW GRADE EASEMENT
- 10' UTILITY EASEMENT
- STREET LIGHT

TRANSECT ZONE: T4
 LOT SQUARE FOOTAGE: 3,233
 BLDG. ENV. WIDTH AT SETBACK: 32.3'

BSE1921\Final Plat\sales maps.dwg

LOT 66
 TERRAVESSA
 FITCHBURG LANDS, LLC

DATE 12-13-2018	PROJECT NO. BSE1921
SCALE 1" = 40'	
IF THIS BAR DOES NOT MEASURE 1" THEN DRAWING IS NOT TO SCALE	

Burse
 surveying & engineering LLC
 2801 International Lane, Suite 101
 Madison, WI 53704 608.250.9263
 Fax: 608.250.9266
 email: mburse@bse-inc.net
 www.bursesurveyengr.com

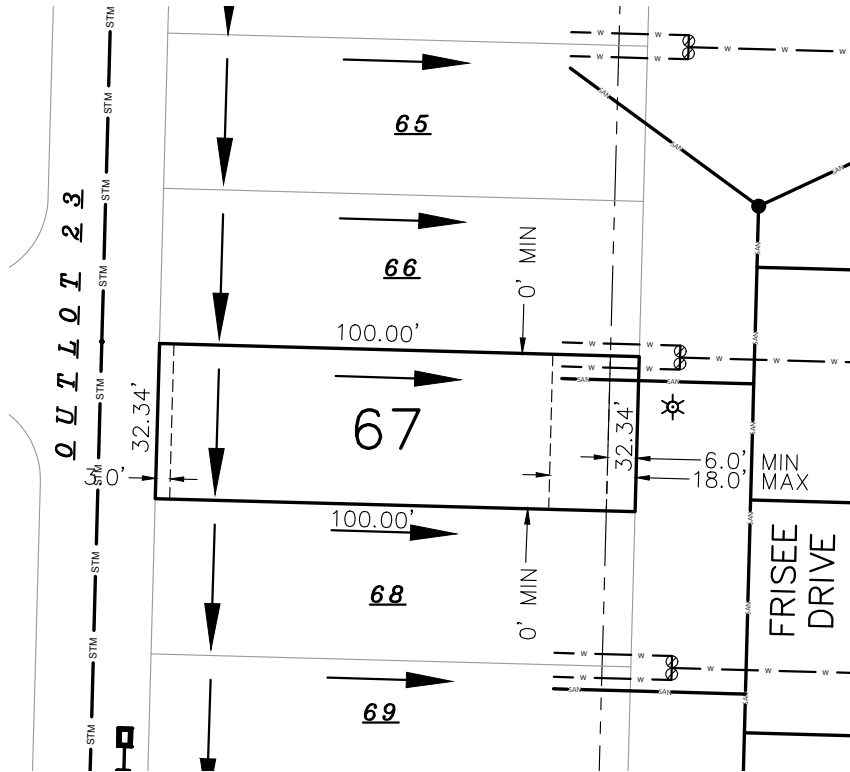

LEGEND

- SURFACE DRAINAGE SWALE DIRECTION
- BUILDING SETBACK LINE
- WATER SERVICE (PROPOSED)
- SANITARY LATERAL (PROPOSED)
- 6' ELECTRIC AND GAS LINES BELOW GRADE EASEMENT
- 10' UTILITY EASEMENT
- STREET LIGHT

TRANSECT ZONE: T4
 LOT SQUARE FOOTAGE: 3,233
 BLDG. ENV. WIDTH AT SETBACK: 32.3'



LOT 67
 TERRAVESSA
 FITCHBURG LANDS, LLC

DATE 12-13-2018	PROJECT NO. BSE1921
SCALE 1" = 40'	
IF THIS BAR DOES NOT MEASURE 1" THEN DRAWING IS NOT TO SCALE	

Burse
 surveying & engineering LLC
 2801 International Lane, Suite 101
 Madison, WI 53704 608.250.9263
 Fax: 608.250.9266
 email: mburse@bse-inc.net
 www.bursesurveyengr.com

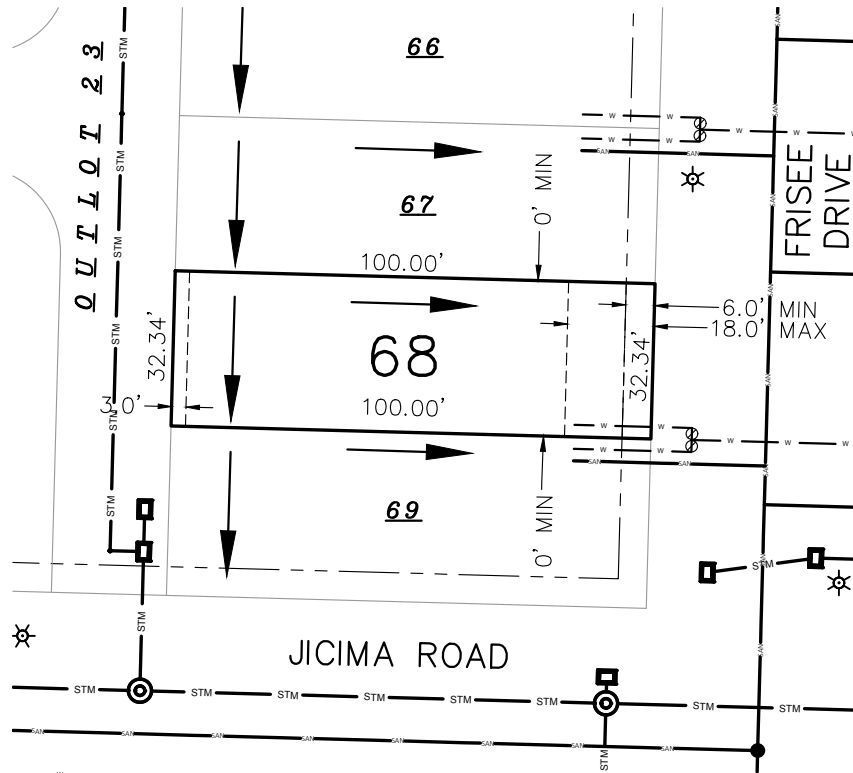

LEGEND

- SURFACE DRAINAGE SWALE DIRECTION
- BUILDING SETBACK LINE
- WATER SERVICE (PROPOSED)
- SANITARY LATERAL (PROPOSED)
- 6' ELECTRIC AND GAS LINES BELOW GRADE EASEMENT
- 10' UTILITY EASEMENT
- STREET LIGHT

TRANSECT ZONE: T4
 LOT SQUARE FOOTAGE: 3,234
 BLDG. ENV. WIDTH AT SETBACK: 32.3'

BSE1921\Final Plat\sales maps.dwg

LOT 68
 TERRAVESSA
 FITCHBURG LANDS, LLC

DATE: 12-13-2018
 PROJECT NO.: BSE1921

SCALE
 1"=40'

IF THIS BAR DOES NOT MEASURE 1"
 THEN DRAWING IS NOT TO SCALE

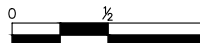

Burse
 surveying & engineering ^{LLC}

2801 International Lane, Suite 101
 Madison, WI 53704 608.250.9263
 Fax: 608.250.9266
 email: mburse@bse-inc.net
 www.bursesurveyengr.com

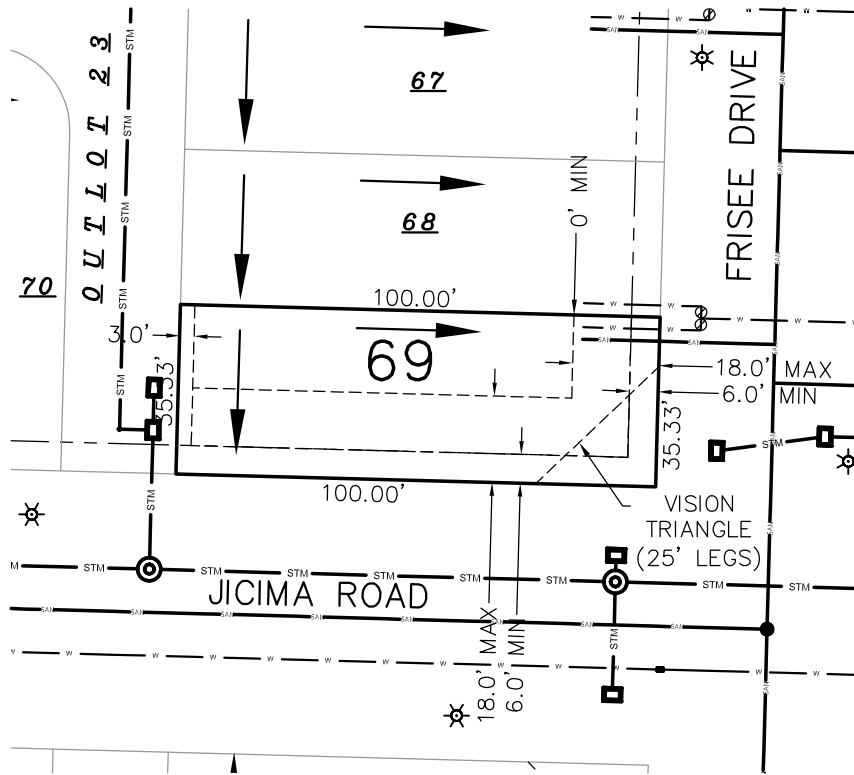

LEGEND

- SURFACE DRAINAGE SWALE DIRECTION
- BUILDING SETBACK LINE
- WATER SERVICE (PROPOSED)
- SANITARY LATERAL (PROPOSED)
- 6' ELECTRIC AND GAS LINES BELOW GRADE EASEMENT
- 10' UTILITY EASEMENT
- STREET LIGHT



TRANSECT ZONE: T4
 LOT SQUARE FOOTAGE: 3,533
 BLDG. ENV. WIDTH AT SETBACK: 29.3'

NOTE:
 AREAS DELINEATED AS VISION TRIANGLE AREAS
 SHALL HAVE NO PLANTINGS OVER TWO (2) FEET
 IN HEIGHT.

TYPICAL VISION CORNER DETAIL

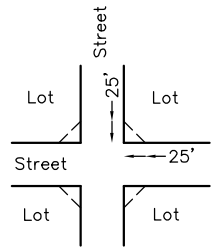

BSE1921\Final Plat\sales maps.dwg

LOT 69
 TERRAVESSA
 FITCHBURG LANDS, LLC

DATE 08-05-2019	PROJECT NO. BSE1921
SCALE 1"=40'	
IF THIS BAR DOES NOT MEASURE 1" THEN DRAWING IS NOT TO SCALE	

Burse
 surveying & engineering Inc.
 2801 International Lane, Suite 101
 Madison, WI 53704 608.250.9263
 Fax: 608.250.9266
 email: mburse@bse-inc.net
 www.bursesurveyengr.com

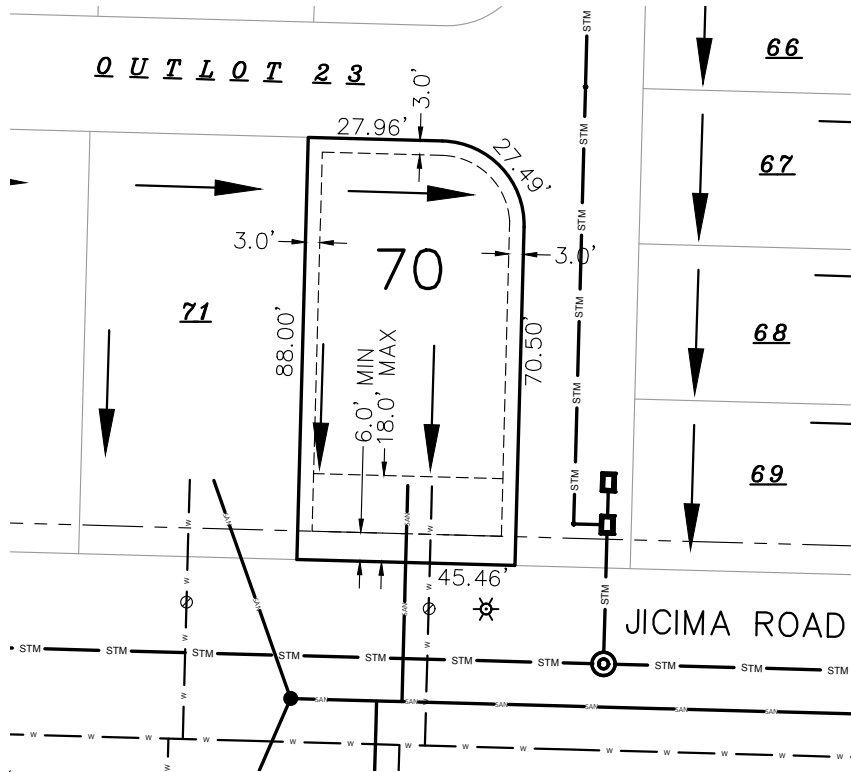

LEGEND

- SURFACE DRAINAGE SWALE DIRECTION
- BUILDING SETBACK LINE
- WATER SERVICE (PROPOSED)
- SANITARY LATERAL (PROPOSED)
- 6' ELECTRIC AND GAS LINES BELOW GRADE EASEMENT
- 10' UTILITY EASEMENT
- STREET LIGHT

TRANSECT ZONE: T4
 LOT SQUARE FOOTAGE: 3,935
 BLDG. ENV. WIDTH AT SETBACK: 39.5'

BSE1921\Final Plat\sales maps.dwg

LOT 70
 TERRAVESSA
 FITCHBURG LANDS, LLC

DATE 12-13-2018	PROJECT NO. BSE1921
SCALE 1" = 40'	
IF THIS BAR DOES NOT MEASURE 1" THEN DRAWING IS NOT TO SCALE	

Burse
 surveying & engineering LLC
 2801 International Lane, Suite 101
 Madison, WI 53704 608.250.9263
 Fax: 608.250.9266
 email: mburse@bse-inc.net
 www.bursesurveyengr.com

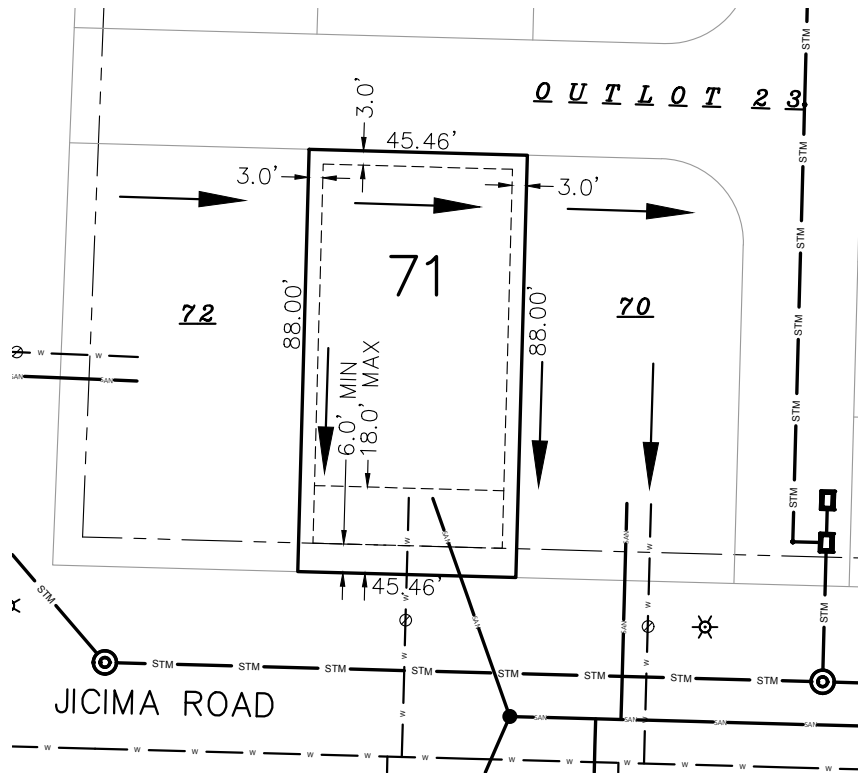

LEGEND

- SURFACE DRAINAGE SWALE DIRECTION
- BUILDING SETBACK LINE
- WATER SERVICE (PROPOSED)
- SANITARY LATERAL (PROPOSED)
- 6' ELECTRIC AND GAS LINES BELOW GRADE EASEMENT
- 10' UTILITY EASEMENT
- STREET LIGHT

TRANSECT ZONE: T4
 LOT SQUARE FOOTAGE: 4,000
 BLDG. ENV. WIDTH AT SETBACK: 39.5'

BSE1921\Final Plat\sales maps.dwg

LOT 71
 TERRAVESSA
 FITCHBURG LANDS, LLC

DATE 12-13-2018	PROJECT NO. BSE1921
SCALE 1" = 40'	
IF THIS BAR DOES NOT MEASURE 1" THEN DRAWING IS NOT TO SCALE	

Burse
 surveying & engineering LLC
 2801 International Lane, Suite 101
 Madison, WI 53704 608.250.9263
 Fax: 608.250.9266
 email: mburse@bse-inc.net
 www.bursesurveyengr.com

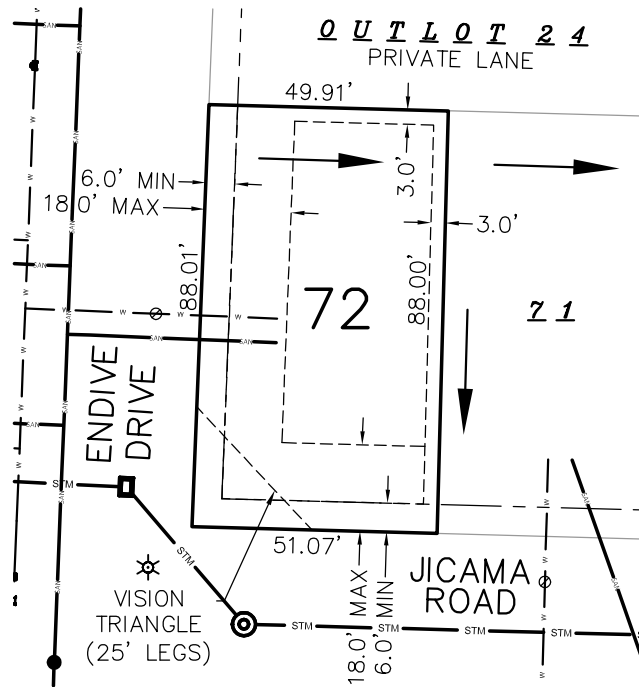

LEGEND

- SURFACE DRAINAGE SWALE DIRECTION
- BUILDING SETBACK LINE
- WATER SERVICE (PROPOSED)
- SANITARY LATERAL (PROPOSED)
- 6' ELECTRIC AND GAS LINES BELOW GRADE EASEMENT
- 10' UTILITY EASEMENT
- STREET LIGHT



TRANSECT ZONE: T4
 LOT SQUARE FOOTAGE: 4,443
 BLDG. ENV. WIDTH AT SETBACK: 42.1'

NOTE:
 AREAS DELINEATED AS VISION TRIANGLE AREAS
 SHALL HAVE NO PLANTINGS OVER TWO (2) FEET
 IN HEIGHT.

TYPICAL VISION CORNER DETAIL

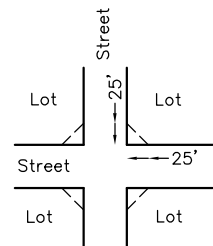

BSE1921\Final Plat\sales maps.dwg

LOT 72
 TERRAVESSA
 FITCHBURG LANDS, LLC

DATE 12-13-2018	PROJECT NO. BSE1921
SCALE 1"=40'	
IF THIS BAR DOES NOT MEASURE 1" THEN DRAWING IS NOT TO SCALE	

Burse
 surveying & engineering Inc.
 2801 International Lane, Suite 101
 Madison, WI 53704 608.250.9263
 Fax: 608.250.9266
 email: mburse@bse-inc.net
 www.bursesurveyengr.com

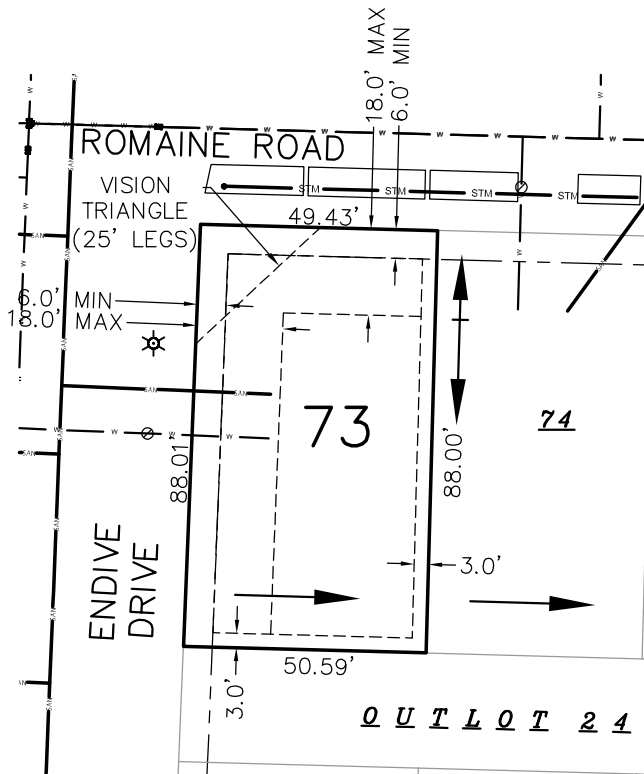

LEGEND

- SURFACE DRAINAGE SWALE DIRECTION
- BUILDING SETBACK LINE
- WATER SERVICE (PROPOSED)
- SANITARY LATERAL (PROPOSED)
- 6' ELECTRIC AND GAS LINES BELOW GRADE EASEMENT
- 10' UTILITY EASEMENT
- STREET LIGHT



TRANSECT ZONE: T4
 LOT SQUARE FOOTAGE: 4,401
 BLDG. ENV. WIDTH AT SETBACK: 40.4'

NOTE:
 AREAS DELINEATED AS VISION TRIANGLE AREAS
 SHALL HAVE NO PLANTINGS OVER TWO (2) FEET
 IN HEIGHT.

TYPICAL VISION CORNER DETAIL

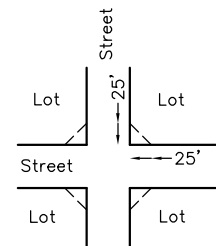

BSE1921\Final Plat\sales maps.dwg

LOT 73
 TERRAVESSA
 FITCHBURG LANDS, LLC

DATE: 08-05-2019
 PROJECT NO.: BSE1921

SCALE
 1"=40'

IF THIS BAR DOES NOT MEASURE 1"
 THEN DRAWING IS NOT TO SCALE

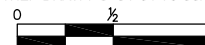

Burse
 surveying & engineering Inc.
 2801 International Lane, Suite 101
 Madison, WI 53704 608.250.9263
 Fax: 608.250.9266
 email: mburse@bse-inc.net
 www.bursesurveyengr.com

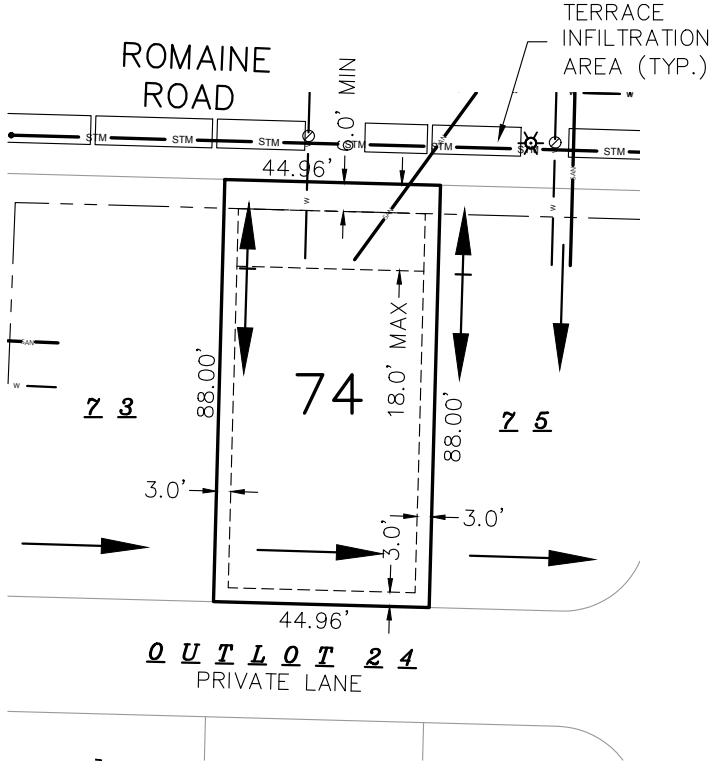

LEGEND

- SURFACE DRAINAGE SWALE DIRECTION
- BUILDING SETBACK LINE
- WATER SERVICE (PROPOSED)
- SANITARY LATERAL (PROPOSED)
- 6' ELECTRIC AND GAS LINES BELOW GRADE EASEMENT
- 10' UTILITY EASEMENT
- STREET LIGHT

TRANSECT ZONE: T4
 LOT SQUARE FOOTAGE: 3,956
 BLDG. ENV. WIDTH AT SETBACK: 39.0'

BSE1921\Final Plat\sales maps.dwg

LOT 74
 TERRAVESSA
 FITCHBURG LANDS, LLC

DATE 12-13-2018	PROJECT NO. BSE1921
SCALE 1" = 40'	
IF THIS BAR DOES NOT MEASURE 1" THEN DRAWING IS NOT TO SCALE	

Burse
 surveying & engineering LLC
 2801 International Lane, Suite 101
 Madison, WI 53704 G08.250.9263
 Fax: G08.250.9266
 email: mburse@bse-inc.net
 www.bursesurveyengr.com

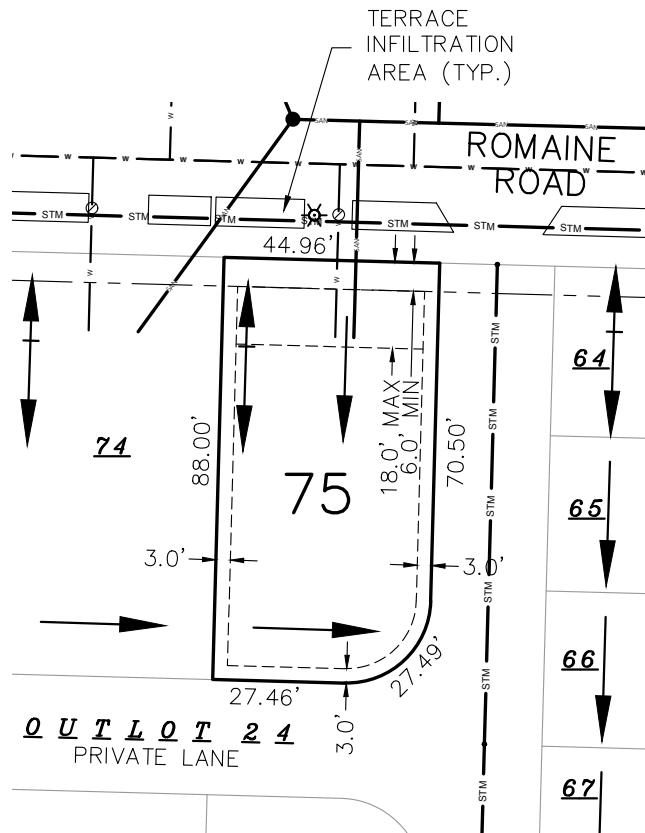

LEGEND

- SURFACE DRAINAGE SWALE DIRECTION
- BUILDING SETBACK LINE
- WATER SERVICE (PROPOSED)
- SANITARY LATERAL (PROPOSED)
- 6' ELECTRIC AND GAS LINES BELOW GRADE EASEMENT
- 10' UTILITY EASEMENT
- STREET LIGHT

TRANSECT ZONE: T4
 LOT SQUARE FOOTAGE: 3,891
 BLDG. ENV. WIDTH AT SETBACK: 39.0'

BSE1921\Final Plat\sales maps.dwg

LOT 75
 TERRAVESSA
 FITCHBURG LANDS, LLC

DATE 02-20-2018	PROJECT NO. BSE1921
SCALE 1" = 40'	
IF THIS BAR DOES NOT MEASURE 1" THEN DRAWING IS NOT TO SCALE	

Burse
 surveying & engineering LLC
 2801 International Lane, Suite 101
 Madison, WI 53704 608.250.9263
 Fax: 608.250.9266
 email: mburse@bse-inc.net
 www.bursesurveyengr.com

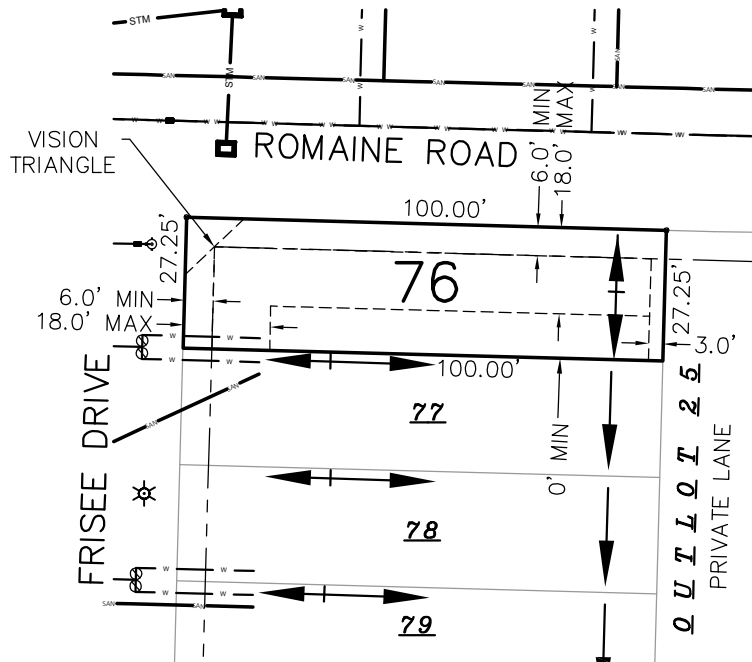

LEGEND

- SURFACE DRAINAGE SWALE DIRECTION
- BUILDING SETBACK LINE
- WATER SERVICE (PROPOSED)
- SANITARY LATERAL (PROPOSED)
- 6' ELECTRIC AND GAS LINES BELOW GRADE EASEMENT
- 10' UTILITY EASEMENT
- STREET LIGHT



TRANSECT ZONE: T4
 LOT SQUARE FOOTAGE: 2,725
 BLDG. ENV. WIDTH AT SETBACK: 21.2'

NOTE:
 AREAS DELINEATED AS VISION TRIANGLE AREAS
 SHALL HAVE NO PLANTINGS OVER TWO (2) FEET
 IN HEIGHT.

TYPICAL VISION CORNER DETAIL

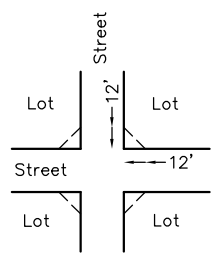

BSE1921\Final Plat\sales maps.dwg

LOT 76
 TERRAVESSA
 FITCHBURG LANDS, LLC

DATE 04/16/2020	PROJECT NO. BSE1921
SCALE 1"=40'	
IF THIS BAR DOES NOT MEASURE 1" THEN DRAWING IS NOT TO SCALE	

Burse
 surveying & engineering Inc.
 2801 International Lane, Suite 101
 Madison, WI 53704 608.250.9263
 Fax: 608.250.9266
 email: mburse@bse-inc.net
 www.bursesurveyengr.com

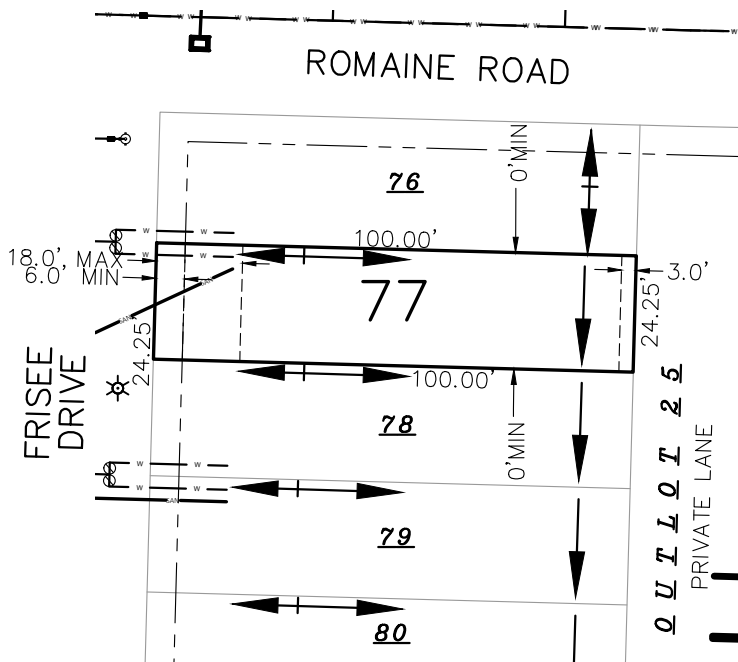

LEGEND

- SURFACE DRAINAGE SWALE DIRECTION
- BUILDING SETBACK LINE
- WATER SERVICE (PROPOSED)
- SANITARY LATERAL (PROPOSED)
- 6' ELECTRIC AND GAS LINES BELOW GRADE EASEMENT
- 10' UTILITY EASEMENT
- STREET LIGHT



TRANSECT ZONE: T4
 LOT SQUARE FOOTAGE: 2,425
 BLDG. ENV. WIDTH AT SETBACK: 24.25'

LOT 77
 TERRAVESSA
 FITCHBURG LANDS, LLC

DATE 02-20-2018	PROJECT NO. BSE1921
SCALE 1" = 40'	
IF THIS BAR DOES NOT MEASURE 1" THEN DRAWING IS NOT TO SCALE	

Burse
 surveying & engineering LLC
 2801 International Lane, Suite 101
 Madison, WI 53704 608.250.9263
 Fax: 608.250.9266
 email: mburse@bse-inc.net
 www.bursesurveyengr.com

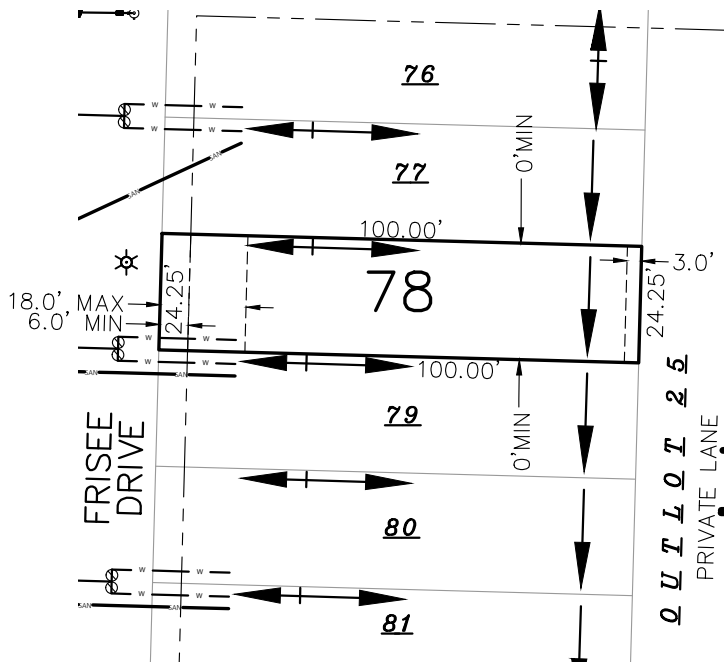

LEGEND

- SURFACE DRAINAGE SWALE DIRECTION
- BUILDING SETBACK LINE
- WATER SERVICE (PROPOSED)
- SANITARY LATERAL (PROPOSED)
- 6' ELECTRIC AND GAS LINES BELOW GRADE EASEMENT
- 10' UTILITY EASEMENT
- STREET LIGHT

TRANSECT ZONE: T4
 LOT SQUARE FOOTAGE: 2,425
 BLDG. ENV. WIDTH AT SETBACK: 24.25'

BSE1921\Final Plat\sales maps.dwg

LOT 78
 TERRAVESSA
 FITCHBURG LANDS, LLC

DATE 12-13-2018	PROJECT NO. BSE1921
SCALE 1" = 40'	
IF THIS BAR DOES NOT MEASURE 1" THEN DRAWING IS NOT TO SCALE	

Burse
 surveying & engineering LLC
 2801 International Lane, Suite 101
 Madison, WI 53704 608.250.9263
 Fax: 608.250.9266
 email: mburse@bse-inc.net
 www.bursesurveyengr.com

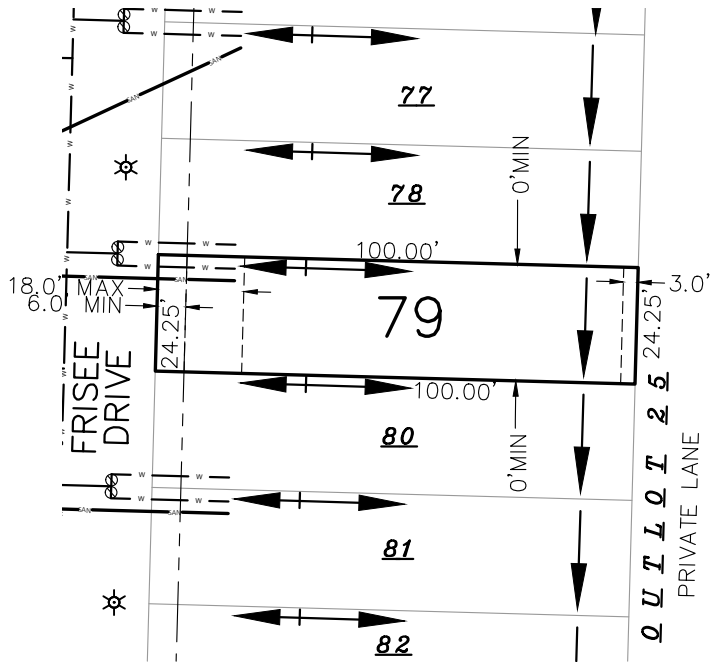

LEGEND

- SURFACE DRAINAGE SWALE DIRECTION
- BUILDING SETBACK LINE
- WATER SERVICE (PROPOSED)
- SANITARY LATERAL (PROPOSED)
- 6' ELECTRIC AND GAS LINES BELOW GRADE EASEMENT
- 10' UTILITY EASEMENT
- STREET LIGHT



TRANSECT ZONE: T4
 LOT SQUARE FOOTAGE: 2,425
 BLDG. ENV. WIDTH AT SETBACK: 24.25'

LOT 79
 TERRAVESSA
 FITCHBURG LANDS, LLC

DATE 12-13-2018	PROJECT NO. BSE1921
SCALE 1" = 40'	
IF THIS BAR DOES NOT MEASURE 1" THEN DRAWING IS NOT TO SCALE	

Burse
 surveying & engineering LLC
 2801 International Lane, Suite 101
 Madison, WI 53704 608.250.9263
 Fax: 608.250.9266
 email: mburse@bse-inc.net
 www.bursesurveyengr.com

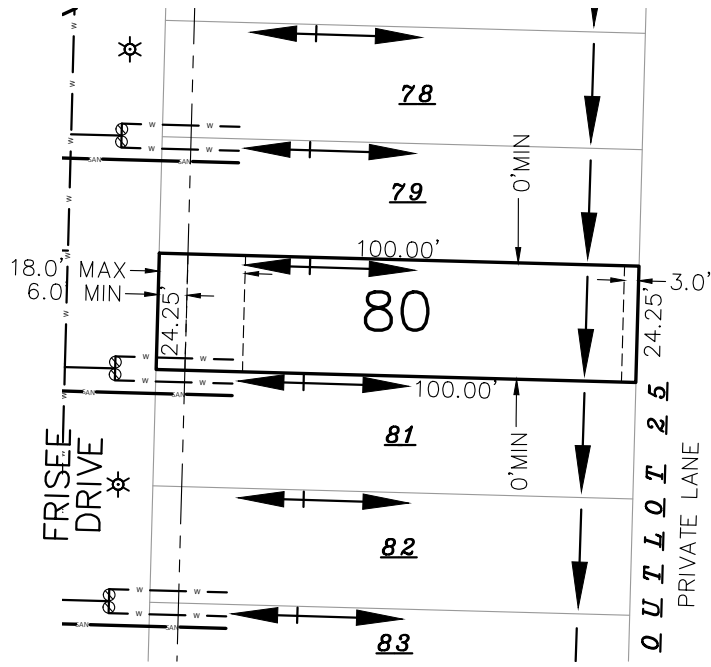

LEGEND

- SURFACE DRAINAGE SWALE DIRECTION
- BUILDING SETBACK LINE
- WATER SERVICE (PROPOSED)
- SANITARY LATERAL (PROPOSED)
- 6' ELECTRIC AND GAS LINES BELOW GRADE EASEMENT
- 10' UTILITY EASEMENT
- STREET LIGHT



TRANSECT ZONE: T4
 LOT SQUARE FOOTAGE: 2,425
 BLDG. ENV. WIDTH AT SETBACK: 24.25'

BSE1921\Final Plat\sales maps.dwg

LOT 80
 TERRAVESSA
 FITCHBURG LANDS, LLC

DATE 12-13-2018	PROJECT NO. BSE1921
SCALE 1" = 40'	
IF THIS BAR DOES NOT MEASURE 1" THEN DRAWING IS NOT TO SCALE	

Burse

surveying & engineering ^{LLC}

2801 International Lane, Suite 101
 Madison, WI 53704 608.250.9263
 Fax: 608.250.9266
 email: mburse@bse-inc.net
 www.bursesurveyengr.com

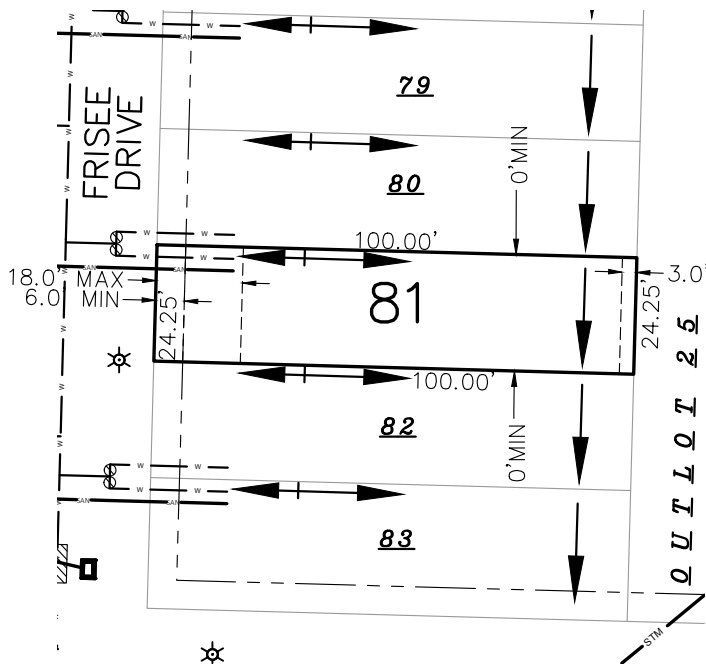

LEGEND

- SURFACE DRAINAGE SWALE DIRECTION
- BUILDING SETBACK LINE
- WATER SERVICE (PROPOSED)
- SANITARY LATERAL (PROPOSED)
- 6' ELECTRIC AND GAS LINES BELOW GRADE EASEMENT
- 10' UTILITY EASEMENT
- STREET LIGHT

TRANSECT ZONE: T4
 LOT SQUARE FOOTAGE: 2,425
 BLDG. ENV. WIDTH AT SETBACK: 24.25'

LOT 81
 TERRAVESSA
 FITCHBURG LANDS, LLC

DATE 12-13-2018	PROJECT NO. BSE1921
SCALE 1" = 40'	
IF THIS BAR DOES NOT MEASURE 1" THEN DRAWING IS NOT TO SCALE	

Burse
 surveying & engineering LLC
 2801 International Lane, Suite 101
 Madison, WI 53704 608.250.9263
 Fax: 608.250.9266
 email: mburse@bse-inc.net
 www.bursesurveyengr.com

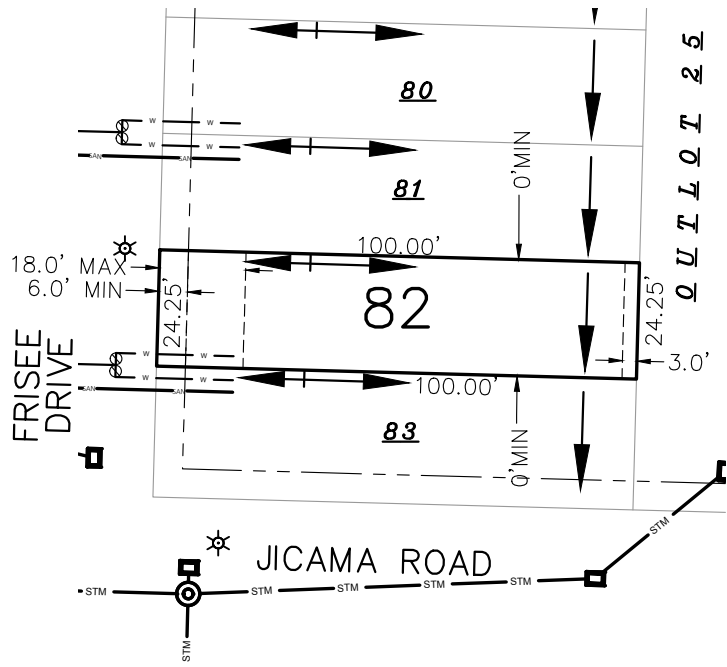

LEGEND

- SURFACE DRAINAGE SWALE DIRECTION
- BUILDING SETBACK LINE
- WATER SERVICE (PROPOSED)
- SANITARY LATERAL (PROPOSED)
- 6' ELECTRIC AND GAS LINES BELOW GRADE EASEMENT
- 10' UTILITY EASEMENT
- STREET LIGHT

TRANSECT ZONE: T4
 LOT SQUARE FOOTAGE: 2,425
 BLDG. ENV. WIDTH AT SETBACK: 24.25'

BSE1921\Final Plat\sales maps.dwg

LOT 82
 TERRAVESSA
 FITCHBURG LANDS, LLC

DATE 12-13-2018	PROJECT NO. BSE1921
SCALE 1" = 40'	
IF THIS BAR DOES NOT MEASURE 1" THEN DRAWING IS NOT TO SCALE	

Burse

surveying & engineering ^{LLC}

2801 International Lane, Suite 101
 Madison, WI 53704 608.250.9263
 Fax: 608.250.9266
 email: mburse@bse-inc.net
 www.bursesurveyengr.com

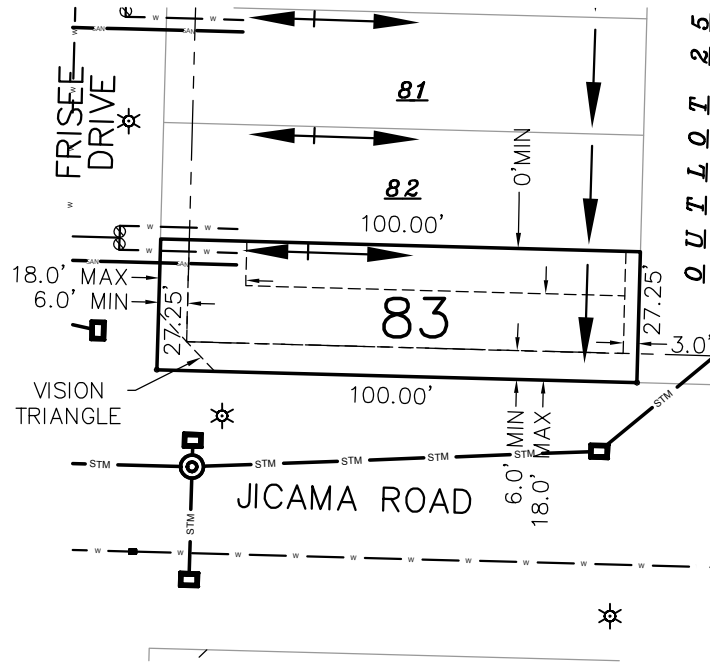

LEGEND

- ← SURFACE DRAINAGE SWALE DIRECTION
- BUILDING SETBACK LINE
- W— WATER SERVICE (PROPOSED)
- SAN— SANITARY LATERAL (PROPOSED)
- 6' ELECTRIC AND GAS LINES BELOW GRADE EASEMENT
- 10' UTILITY EASEMENT
- ☼ STREET LIGHT



TRANSECT ZONE: T4
 LOT SQUARE FOOTAGE: 2,725
 BLDG. ENV. WIDTH AT SETBACK: 21.2'

NOTE:
 AREAS DELINEATED AS VISION TRIANGLE AREAS
 SHALL HAVE NO PLANTINGS OVER TWO (2) FEET
 IN HEIGHT.

TYPICAL VISION CORNER DETAIL

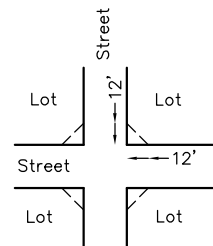

BSE1921\Final Plat\sales maps.dwg

LOT 83
 TERRAVESSA
 FITCHBURG LANDS, LLC

DATE: 04/16/2020
 PROJECT NO.: BSE1921

SCALE
 1" = 40'

IF THIS BAR DOES NOT MEASURE 1"
 THEN DRAWING IS NOT TO SCALE

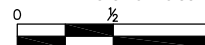

Burse
 surveying & engineering Inc.
 2801 International Lane, Suite 101
 Madison, WI 53704 608.250.9263
 Fax: 608.250.9266
 email: mburse@bse-inc.net
 www.bursesurveyengr.com

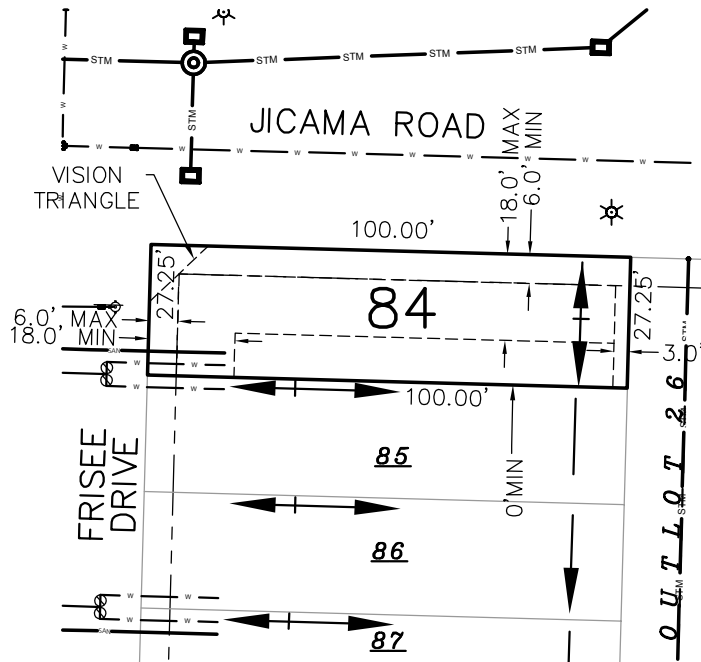

LEGEND

- SURFACE DRAINAGE SWALE DIRECTION
- BUILDING SETBACK LINE
- WATER SERVICE (PROPOSED)
- SANITARY LATERAL (PROPOSED)
- 6' ELECTRIC AND GAS LINES BELOW GRADE EASEMENT
- 10' UTILITY EASEMENT
- STREET LIGHT



TRANSECT ZONE: T4
 LOT SQUARE FOOTAGE: 2,725
 BLDG. ENV. WIDTH AT SETBACK: 21.2'

NOTE:
 AREAS DELINEATED AS VISION TRIANGLE AREAS
 SHALL HAVE NO PLANTINGS OVER TWO (2) FEET
 IN HEIGHT.

TYPICAL VISION CORNER DETAIL

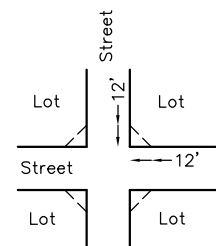

BSE1921\Final Plat\sales maps.dwg

LOT 84
 TERRAVESSA
 FITCHBURG LANDS, LLC

DATE: 04/16/2020
 PROJECT NO.: BSE1921

SCALE: 1" = 40'

IF THIS BAR DOES NOT MEASURE 1" THEN DRAWING IS NOT TO SCALE

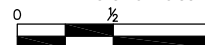

Burse
 surveying & engineering Inc.

2801 International Lane, Suite 101
 Madison, WI 53704 608.250.9263
 Fax: 608.250.9266
 email: mburse@bse-inc.net
 www.bursesurveyengr.com

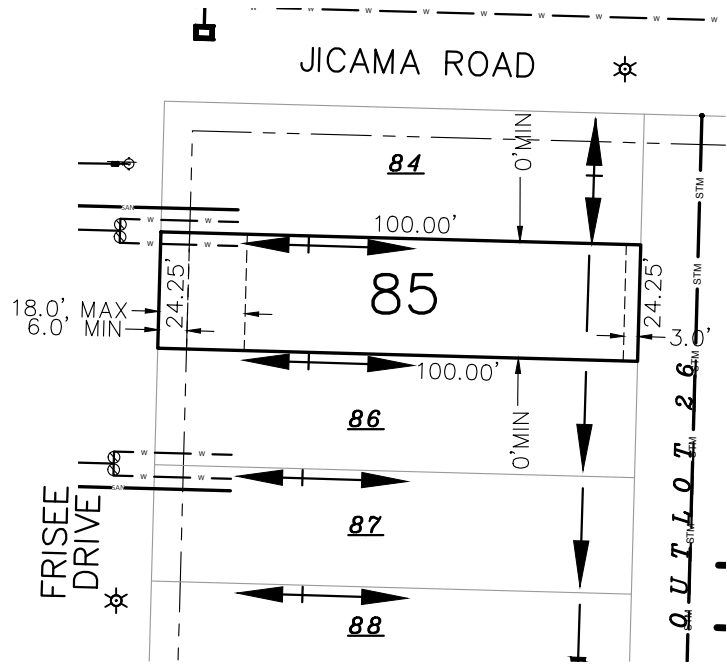

LEGEND

- SURFACE DRAINAGE SWALE DIRECTION
- BUILDING SETBACK LINE
- WATER SERVICE (PROPOSED)
- SANITARY LATERAL (PROPOSED)
- 6' ELECTRIC AND GAS LINES BELOW GRADE EASEMENT
- 10' UTILITY EASEMENT
- STREET LIGHT

TRANSECT ZONE: T4
 LOT SQUARE FOOTAGE: 2,425
 BLDG. ENV. WIDTH AT SETBACK: 24.25'

BSE1921\Final Plat\sales maps.dwg

LOT 85
 TERRAVESSA
 FITCHBURG LANDS, LLC

DATE 12-13-2018	PROJECT NO. BSE1921
SCALE 1" = 40'	
IF THIS BAR DOES NOT MEASURE 1" THEN DRAWING IS NOT TO SCALE	

Burse
 surveying & engineering LLC

2801 International Lane, Suite 101
 Madison, WI 53704 608.250.9263
 Fax: 608.250.9266
 email: mburse@bse-inc.net
 www.bursesurveyengr.com

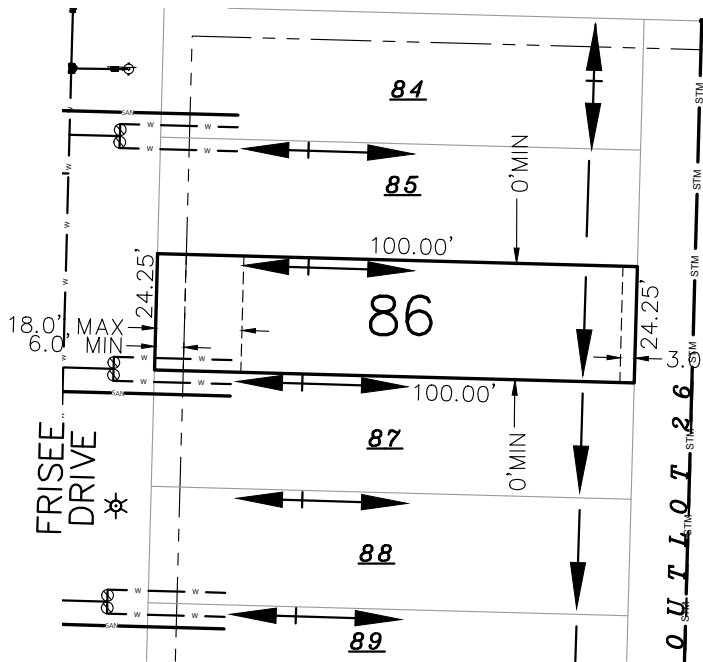

LEGEND

- SURFACE DRAINAGE SWALE DIRECTION
- BUILDING SETBACK LINE
- WATER SERVICE (PROPOSED)
- SANITARY LATERAL (PROPOSED)
- 6' ELECTRIC AND GAS LINES BELOW GRADE EASEMENT
- 10' UTILITY EASEMENT
- STREET LIGHT



TRANSECT ZONE: T4
 LOT SQUARE FOOTAGE: 2,425
 BLDG. ENV. WIDTH AT SETBACK: 24.25'

LOT 86
 TERRAVESSA
 FITCHBURG LANDS, LLC

DATE 12-13-2018	PROJECT NO. BSE1921
SCALE 1" = 40'	
IF THIS BAR DOES NOT MEASURE 1" THEN DRAWING IS NOT TO SCALE	

Burse
 surveying & engineering ^{LLC}
 2801 International Lane, Suite 101
 Madison, WI 53704 608.250.9263
 Fax: 608.250.9266
 email: mburse@bse-inc.net
 www.bursesurveyengr.com

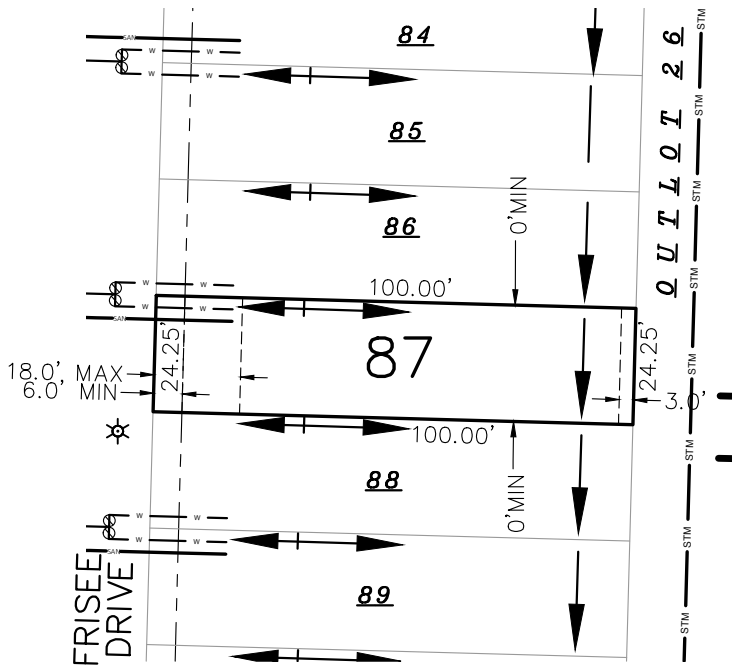

LEGEND

- SURFACE DRAINAGE SWALE DIRECTION
- BUILDING SETBACK LINE
- WATER SERVICE (PROPOSED)
- SANITARY LATERAL (PROPOSED)
- 6' ELECTRIC AND GAS LINES BELOW GRADE EASEMENT
- 10' UTILITY EASEMENT
- STREET LIGHT

TRANSECT ZONE: T4
 LOT SQUARE FOOTAGE: 2,425
 BLDG. ENV. WIDTH AT SETBACK: 24.25'

LOT 87
 TERRAVESSA
 FITCHBURG LANDS, LLC

DATE 12-13-2018	PROJECT NO. BSE1921
SCALE 1" = 40'	
IF THIS BAR DOES NOT MEASURE 1" THEN DRAWING IS NOT TO SCALE	

Burse
 surveying & engineering LLC
 2801 International Lane, Suite 101
 Madison, WI 53704 608.250.9263
 Fax: 608.250.9266
 email: mburse@bse-inc.net
 www.bursesurveyengr.com

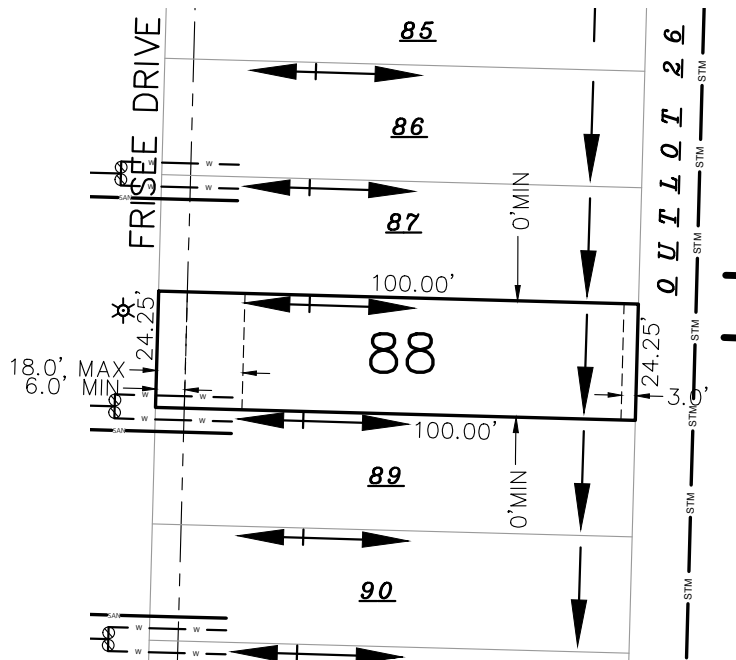

LEGEND

- SURFACE DRAINAGE SWALE DIRECTION
- BUILDING SETBACK LINE
- WATER SERVICE (PROPOSED)
- SANITARY LATERAL (PROPOSED)
- 6' ELECTRIC AND GAS LINES BELOW GRADE EASEMENT
- 10' UTILITY EASEMENT
- STREET LIGHT

TRANSECT ZONE: T4
 LOT SQUARE FOOTAGE: 2,425
 BLDG. ENV. WIDTH AT SETBACK: 24.25'

LOT 88
 TERRAVESSA
 FITCHBURG LANDS, LLC

DATE 12-13-2018	PROJECT NO. BSE1921
SCALE 1" = 40'	
IF THIS BAR DOES NOT MEASURE 1" THEN DRAWING IS NOT TO SCALE	

Burse
 surveying & engineering LLC
 2801 International Lane, Suite 101
 Madison, WI 53704 608.250.9263
 Fax: 608.250.9266
 email: mburse@bse-inc.net
 www.bursesurveyengr.com

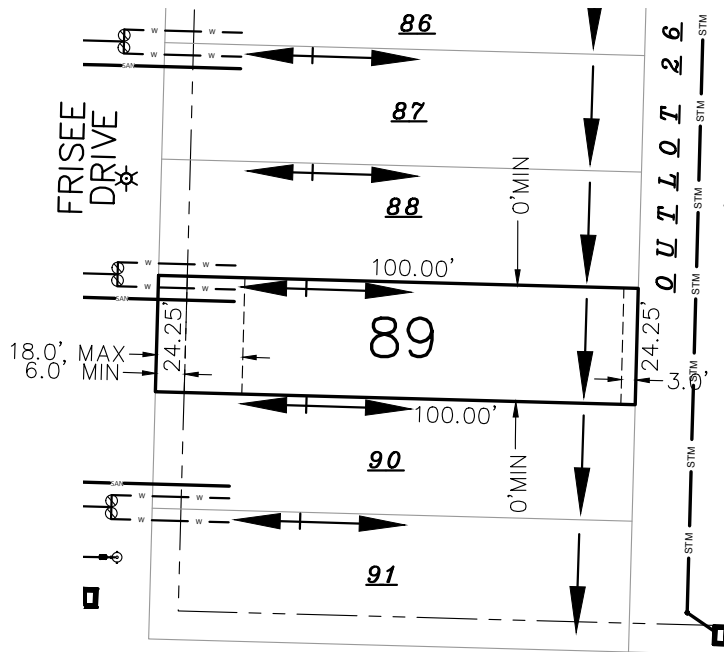

LEGEND

- SURFACE DRAINAGE SWALE DIRECTION
- BUILDING SETBACK LINE
- WATER SERVICE (PROPOSED)
- SANITARY LATERAL (PROPOSED)
- 6' ELECTRIC AND GAS LINES BELOW GRADE EASEMENT
- 10' UTILITY EASEMENT
- STREET LIGHT

TRANSECT ZONE: T4
 LOT SQUARE FOOTAGE: 2,425
 BLDG. ENV. WIDTH AT SETBACK: 24.25'

LOT 89
 TERRAVESSA
 FITCHBURG LANDS, LLC

DATE 12-13-2018	PROJECT NO. BSE1921
SCALE 1" = 40'	
IF THIS BAR DOES NOT MEASURE 1" THEN DRAWING IS NOT TO SCALE	

Burse
 surveying & engineering LLC
 2801 International Lane, Suite 101
 Madison, WI 53704 608.250.9263
 Fax: 608.250.9266
 email: mburse@bse-inc.net
 www.bursesurveyengr.com

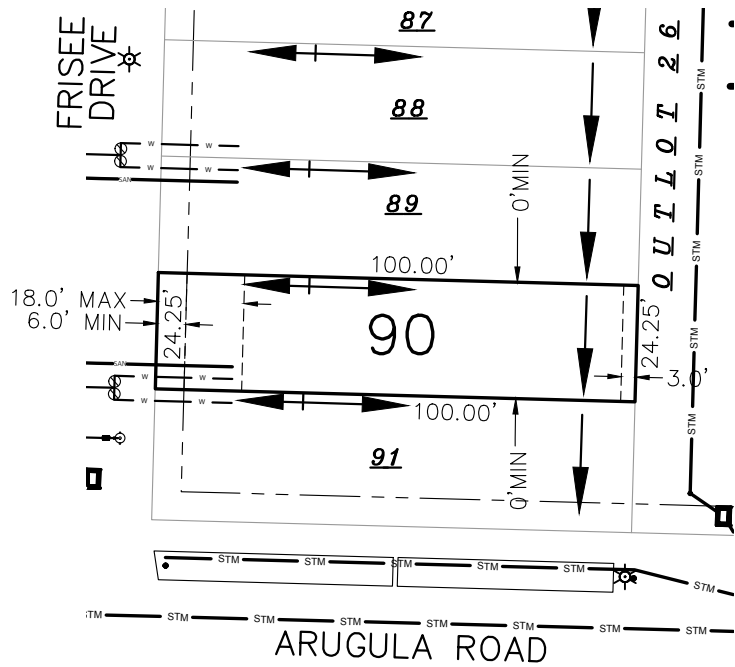

LEGEND

- SURFACE DRAINAGE SWALE DIRECTION
- BUILDING SETBACK LINE
- WATER SERVICE (PROPOSED)
- SANITARY LATERAL (PROPOSED)
- 6' ELECTRIC AND GAS LINES BELOW GRADE EASEMENT
- 10' UTILITY EASEMENT
- STREET LIGHT

TRANSECT ZONE: T4
 LOT SQUARE FOOTAGE: 2,425
 BLDG. ENV. WIDTH AT SETBACK: 24.25'

BSE1921\Final Plat\sales maps.dwg

LOT 90
 TERRAVESSA
 FITCHBURG LANDS, LLC

DATE 12-13-2018	PROJECT NO. BSE1921
SCALE 1" = 40'	
IF THIS BAR DOES NOT MEASURE 1" THEN DRAWING IS NOT TO SCALE	

Burse

surveying & engineering ^{LLC}

2801 International Lane, Suite 101
 Madison, WI 53704 608.250.9263
 Fax: 608.250.9266
 email: mburse@bse-inc.net
 www.bursesurveyengr.com

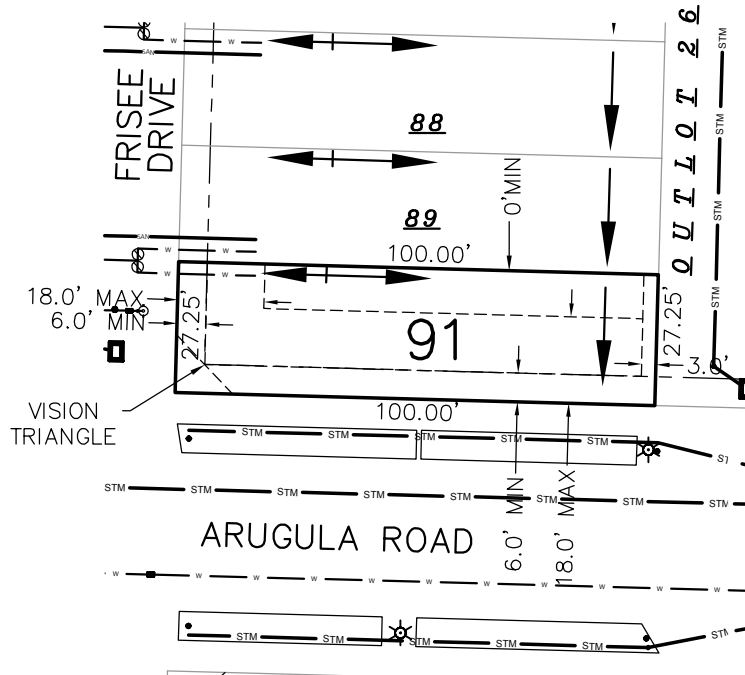

LEGEND

- SURFACE DRAINAGE SWALE DIRECTION
- BUILDING SETBACK LINE
- WATER SERVICE (PROPOSED)
- SANITARY LATERAL (PROPOSED)
- 6' ELECTRIC AND GAS LINES BELOW GRADE EASEMENT
- 10' UTILITY EASEMENT
- STREET LIGHT



TRANSECT ZONE: T4
 LOT SQUARE FOOTAGE: 2,725
 BLDG. ENV. WIDTH AT SETBACK: 21.2'

NOTE:
 AREAS DELINEATED AS VISION TRIANGLE AREAS
 SHALL HAVE NO PLANTINGS OVER TWO (2) FEET
 IN HEIGHT.

TYPICAL VISION CORNER DETAIL

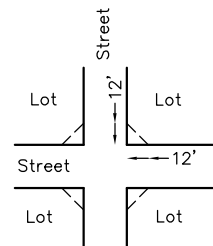

BSE1921\Final Plat\sales maps.dwg

LOT 91
 TERRAVESSA
 FITCHBURG LANDS, LLC

DATE: 04/16/2020 PROJECT NO.: BSE1921

SCALE
 1"=40'

IF THIS BAR DOES NOT MEASURE 1"
 THEN DRAWING IS NOT TO SCALE

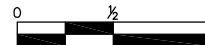

Burse
 surveying & engineering Inc.

2801 International Lane, Suite 101
 Madison, WI 53704 608.250.9263
 Fax: 608.250.9266
 email: mburse@bse-inc.net
 www.bursesurveyengr.com

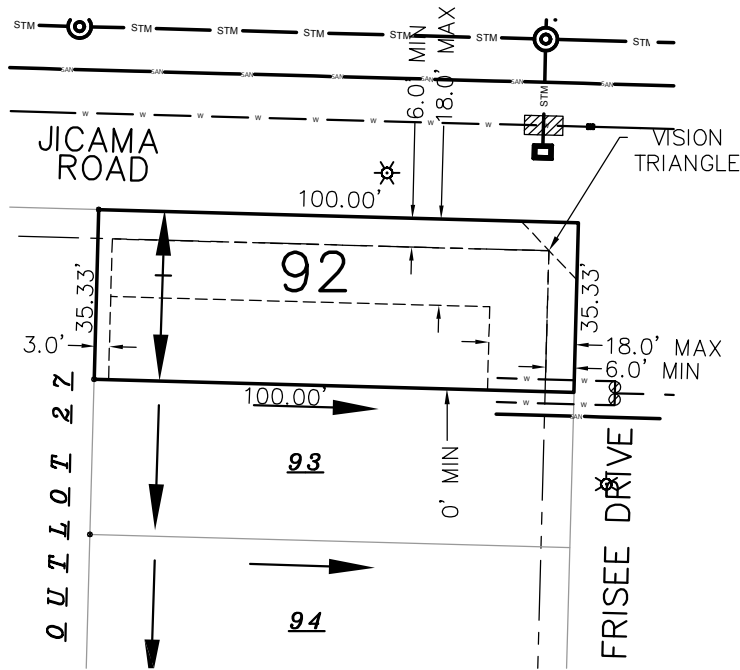

LEGEND

- SURFACE DRAINAGE SWALE DIRECTION
- BUILDING SETBACK LINE
- WATER SERVICE (PROPOSED)
- SANITARY LATERAL (PROPOSED)
- 6' ELECTRIC AND GAS LINES BELOW GRADE EASEMENT
- 10' UTILITY EASEMENT
- STREET LIGHT



TRANSECT ZONE: T4
 LOT SQUARE FOOTAGE: 3,533
 BLDG. ENV. WIDTH AT SETBACK: 29.3'

NOTE:
 AREAS DELINEATED AS VISION TRIANGLE AREAS
 SHALL HAVE NO PLANTINGS OVER TWO (2) FEET
 IN HEIGHT.

TYPICAL VISION CORNER DETAIL

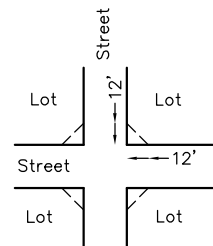

BSE1921\Final Plat\sales maps.dwg

LOT 92
 TERRAVESSA
 FITCHBURG LANDS, LLC

DATE 04/16/2020	PROJECT NO. BSE1921
SCALE 1"=40'	
IF THIS BAR DOES NOT MEASURE 1" THEN DRAWING IS NOT TO SCALE	

Burse
 surveying & engineering Inc.
 2801 International Lane, Suite 101
 Madison, WI 53704 608.250.9263
 Fax: 608.250.9266
 email: mburse@bse-inc.net
 www.bursesurveyengr.com

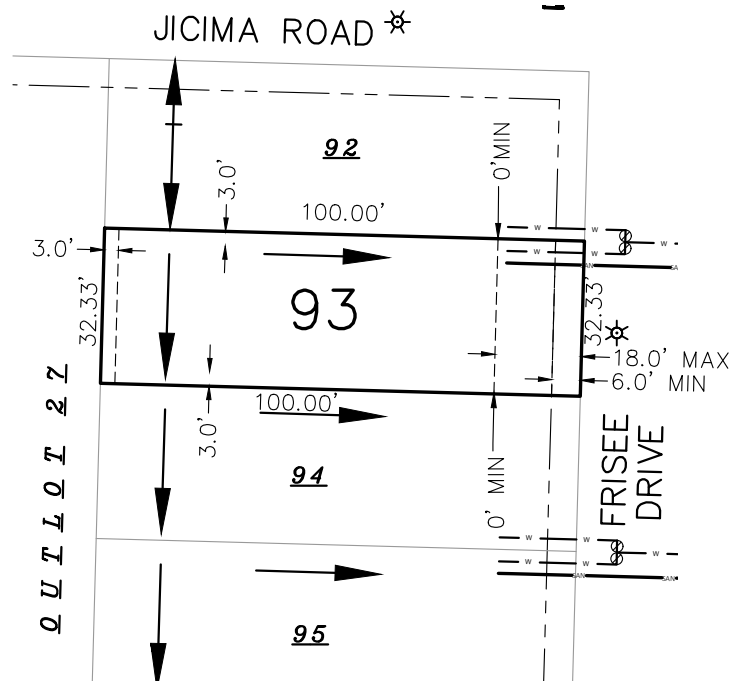

LEGEND

- SURFACE DRAINAGE SWALE DIRECTION
- BUILDING SETBACK LINE
- WATER SERVICE (PROPOSED)
- SANITARY LATERAL (PROPOSED)
- 6' ELECTRIC AND GAS LINES BELOW GRADE EASEMENT
- 10' UTILITY EASEMENT
- STREET LIGHT



TRANSECT ZONE: T4
 LOT SQUARE FOOTAGE: 3,233
 BLDG. ENV. WIDTH AT SETBACK: 32.3'

BSE1921\Final Plat\sales maps.dwg

LOT 93
 TERRAVESSA
 FITCHBURG LANDS, LLC

DATE 12-13-2018	PROJECT NO. BSE1921
SCALE 1" = 40'	
IF THIS BAR DOES NOT MEASURE 1" THEN DRAWING IS NOT TO SCALE	

Burse
 surveying & engineering ^{LLC}
 2801 International Lane, Suite 101
 Madison, WI 53704 G08.250.9263
 Fax: G08.250.9266
 email: mburse@bse-inc.net
 www.bursesurveyengr.com

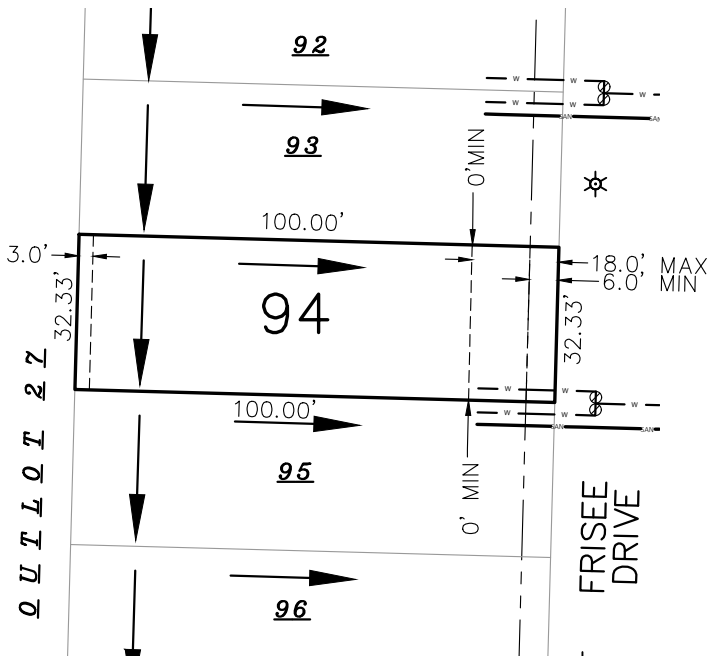

LEGEND

- SURFACE DRAINAGE SWALE DIRECTION
- BUILDING SETBACK LINE
- WATER SERVICE (PROPOSED)
- SANITARY LATERAL (PROPOSED)
- 6' ELECTRIC AND GAS LINES BELOW GRADE EASEMENT
- 10' UTILITY EASEMENT
- STREET LIGHT

TRANSECT ZONE: T4
 LOT SQUARE FOOTAGE: 3,233
 BLDG. ENV. WIDTH AT SETBACK: 32.3'

BSE1921\Final Plat\sales maps.dwg

LOT 94
 TERRAVESSA
 FITCHBURG LANDS, LLC

DATE 12-13-2018	PROJECT NO. BSE1921
SCALE 1" = 40'	
IF THIS BAR DOES NOT MEASURE 1" THEN DRAWING IS NOT TO SCALE	

Burse
 surveying & engineering LLC
 2801 International Lane, Suite 101
 Madison, WI 53704 608.250.9263
 Fax: 608.250.9266
 email: mburse@bse-inc.net
 www.bursesurveyengr.com

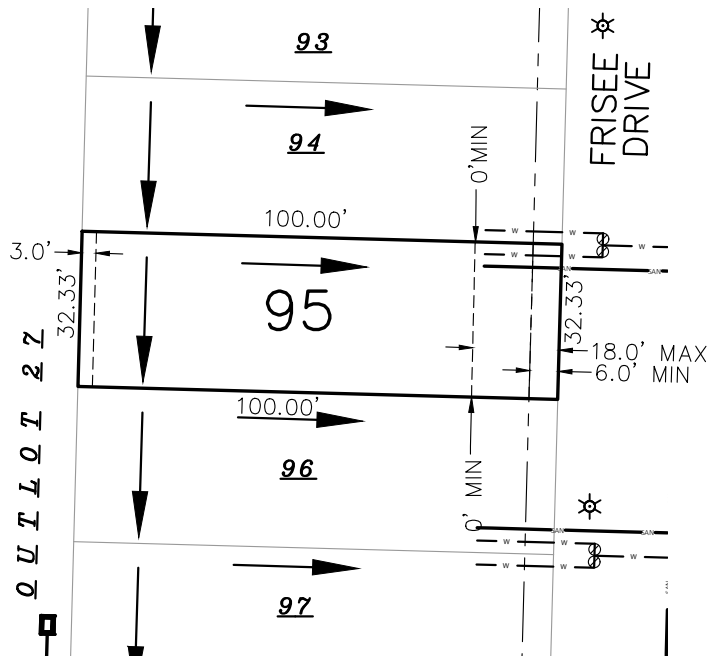

LEGEND

- SURFACE DRAINAGE SWALE DIRECTION
- BUILDING SETBACK LINE
- WATER SERVICE (PROPOSED)
- SANITARY LATERAL (PROPOSED)
- 6' ELECTRIC AND GAS LINES BELOW GRADE EASEMENT
- 10' UTILITY EASEMENT
- STREET LIGHT



TRANSECT ZONE: T4
 LOT SQUARE FOOTAGE: 3,233
 BLDG. ENV. WIDTH AT SETBACK: 32.3'

LOT 95
 TERRAVESSA
 FITCHBURG LANDS, LLC

DATE 12-13-2018	PROJECT NO. BSE1921
SCALE 1" = 40'	
IF THIS BAR DOES NOT MEASURE 1" THEN DRAWING IS NOT TO SCALE	

Burse
 surveying & engineering LLC
 2801 International Lane, Suite 101
 Madison, WI 53704 G08.250.9263
 Fax: G08.250.9266
 email: mburse@bse-inc.net
 www.bursesurveyengr.com

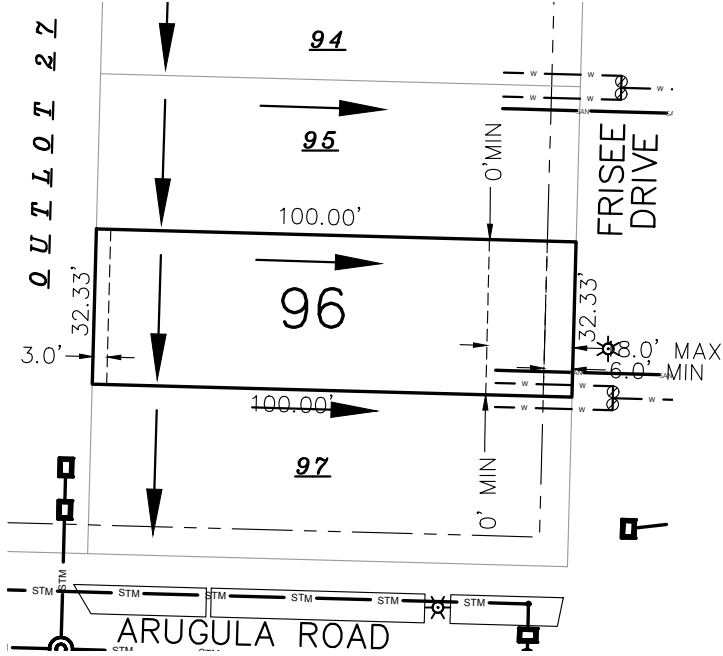

LEGEND

- SURFACE DRAINAGE SWALE DIRECTION
- BUILDING SETBACK LINE
- WATER SERVICE (PROPOSED)
- SANITARY LATERAL (PROPOSED)
- 6' ELECTRIC AND GAS LINES BELOW GRADE EASEMENT
- 10' UTILITY EASEMENT
- STREET LIGHT



TRANSECT ZONE: T4
 LOT SQUARE FOOTAGE: 3,233
 BLDG. ENV. WIDTH AT SETBACK: 32.3'

BSE1921\Final Plat\sales maps.dwg

LOT 96
 TERRAVESSA
 FITCHBURG LANDS, LLC

DATE 02-20-2018	PROJECT NO. BSE1921
SCALE 1" = 40'	
IF THIS BAR DOES NOT MEASURE 1" THEN DRAWING IS NOT TO SCALE	

Burse
 surveying & engineering LLC
 2801 International Lane, Suite 101
 Madison, WI 53704 608.250.9263
 Fax: 608.250.9266
 email: mburse@bse-inc.net
 www.bursesurveyengr.com

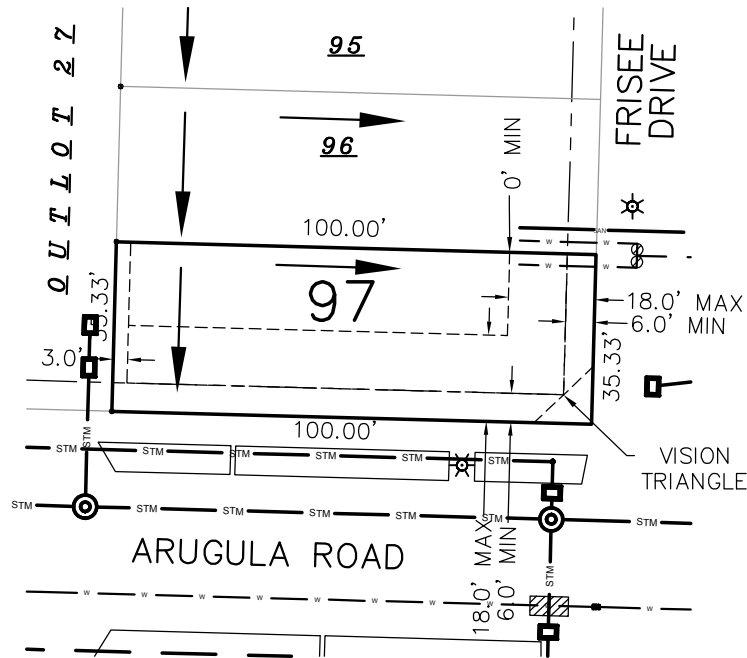

LEGEND

- SURFACE DRAINAGE SWALE DIRECTION
- BUILDING SETBACK LINE
- WATER SERVICE (PROPOSED)
- SANITARY LATERAL (PROPOSED)
- 6' ELECTRIC AND GAS LINES BELOW GRADE EASEMENT
- 10' UTILITY EASEMENT
- STREET LIGHT



TRANSECT ZONE: T4
 LOT SQUARE FOOTAGE: 3,533
 BLDG. ENV. WIDTH AT SETBACK: 29.3'

NOTE:
 AREAS DELINEATED AS VISION TRIANGLE AREAS
 SHALL HAVE NO PLANTINGS OVER TWO (2) FEET
 IN HEIGHT.

TYPICAL VISION CORNER DETAIL

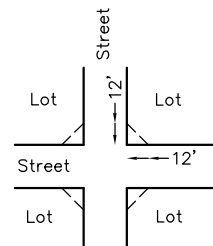

BSE1921\Final Plat\sales maps.dwg

LOT 97
 TERRAVESSA
 FITCHBURG LANDS, LLC

DATE: 04/16/2020 PROJECT NO.: BSE1921

SCALE
 1"=40'

IF THIS BAR DOES NOT MEASURE 1"
 THEN DRAWING IS NOT TO SCALE

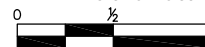

Burse
 surveying & engineering Inc.

2801 International Lane, Suite 101
 Madison, WI 53704 608.250.9263
 Fax: 608.250.9266
 email: mburse@bse-inc.net
 www.bursesurveyengr.com

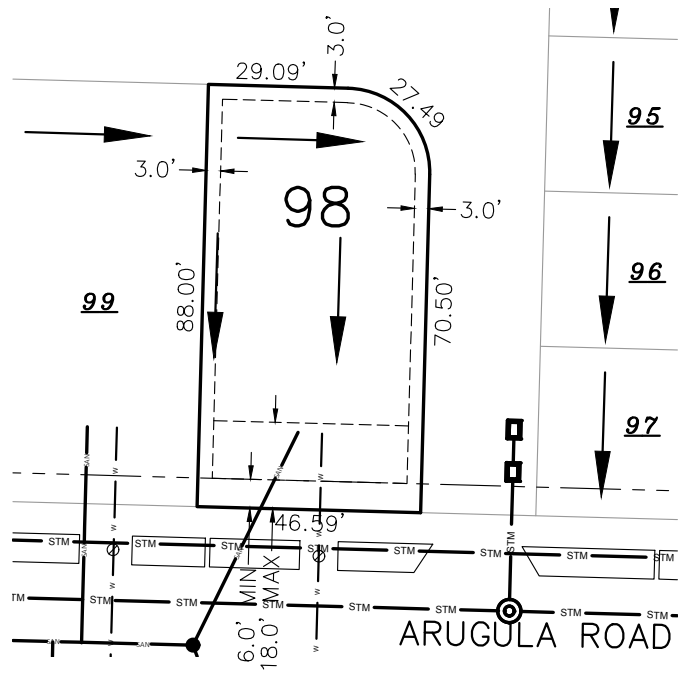

LEGEND

- SURFACE DRAINAGE SWALE DIRECTION
- BUILDING SETBACK LINE
- WATER SERVICE (PROPOSED)
- SANITARY LATERAL (PROPOSED)
- 6' ELECTRIC AND GAS LINES BELOW GRADE EASEMENT
- 10' UTILITY EASEMENT
- STREET LIGHT



TRANSECT ZONE: T4
 LOT SQUARE FOOTAGE: 4,034
 BLDG. ENV. WIDTH AT SETBACK: 40.6'

BSE1921\Final Plat\sales maps.dwg

LOT 98
 TERRAVESSA
 FITCHBURG LANDS, LLC

DATE 02-20-2018	PROJECT NO. BSE1921
SCALE 1" = 40'	
IF THIS BAR DOES NOT MEASURE 1" THEN DRAWING IS NOT TO SCALE	

Burse
 surveying & engineering ^{LLC}
 2801 International Lane, Suite 101
 Madison, WI 53704 608.250.9263
 Fax: 608.250.9266
 email: mburse@bse-inc.net
 www.bursesurveyengr.com

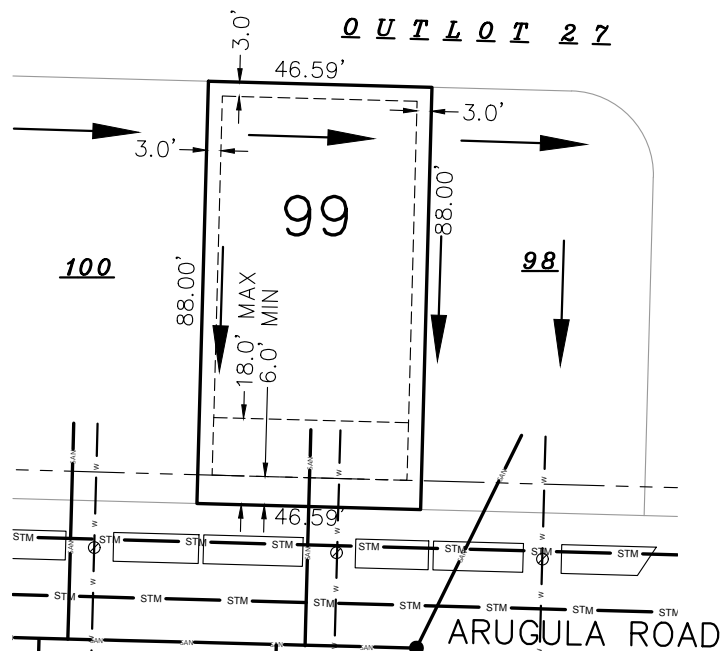

LEGEND

- SURFACE DRAINAGE SWALE DIRECTION
- BUILDING SETBACK LINE
- WATER SERVICE (PROPOSED)
- SANITARY LATERAL (PROPOSED)
- 6' ELECTRIC AND GAS LINES BELOW GRADE EASEMENT
- 10' UTILITY EASEMENT
- STREET LIGHT

TRANSECT ZONE: T4
 LOT SQUARE FOOTAGE: 4,100
 BLDG. ENV. WIDTH AT SETBACK: 40.6'

BSE1921\Final Plat\sales maps.dwg

LOT 99
 TERRAVESSA
 FITCHBURG LANDS, LLC

DATE 02-20-2018	PROJECT NO. BSE1921
SCALE 1" = 40'	
IF THIS BAR DOES NOT MEASURE 1" THEN DRAWING IS NOT TO SCALE	

Burse
 surveying & engineering LLC
 2801 International Lane, Suite 101
 Madison, WI 53704 608.250.9263
 Fax: 608.250.9266
 email: mburse@bse-inc.net
 www.bursesurveyengr.com

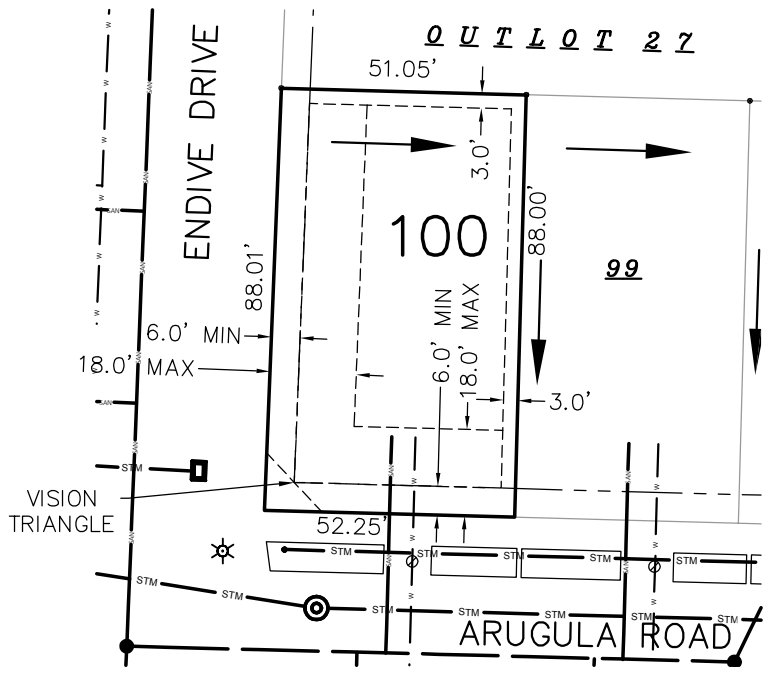

LEGEND

- SURFACE DRAINAGE SWALE DIRECTION
- BUILDING SETBACK LINE
- WATER SERVICE (PROPOSED)
- SANITARY LATERAL (PROPOSED)
- 6' ELECTRIC AND GAS LINES BELOW GRADE EASEMENT
- 10' UTILITY EASEMENT
- STREET LIGHT



TRANSECT ZONE: T4
 LOT SQUARE FOOTAGE: 4,544
 BLDG. ENV. WIDTH AT SETBACK: 43.3'

NOTE:
 AREAS DELINEATED AS VISION TRIANGLE AREAS
 SHALL HAVE NO PLANTINGS OVER TWO (2) FEET
 IN HEIGHT.

TYPICAL VISION CORNER DETAIL

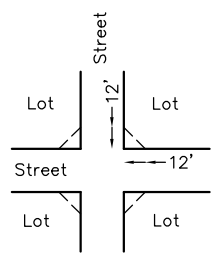

BSE1921\Final Plat\sales maps.dwg

LOT 100
 TERRAVESSA
 FITCHBURG LANDS, LLC

DATE 04/16/2020	PROJECT NO. BSE1921
SCALE 1"=40'	
IF THIS BAR DOES NOT MEASURE 1" THEN DRAWING IS NOT TO SCALE	

Burse
 surveying & engineering Inc.
 2801 International Lane, Suite 101
 Madison, WI 53704 608.250.9263
 Fax: 608.250.9266
 email: mburse@bse-inc.net
 www.bursesurveyengr.com

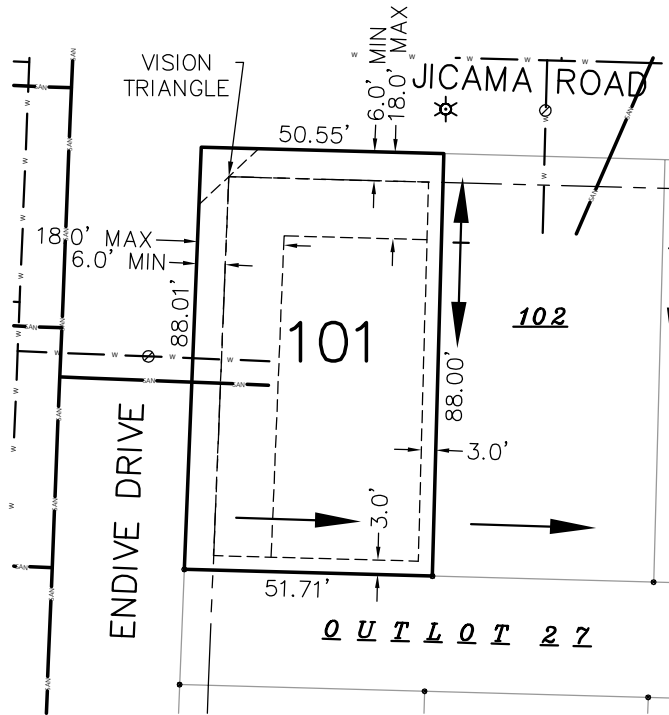

LEGEND

- SURFACE DRAINAGE SWALE DIRECTION
- BUILDING SETBACK LINE
- WATER SERVICE (PROPOSED)
- SANITARY LATERAL (PROPOSED)
- 6' ELECTRIC AND GAS LINES BELOW GRADE EASEMENT
- 10' UTILITY EASEMENT
- STREET LIGHT



TRANSECT ZONE: T4
 LOT SQUARE FOOTAGE: 4,500
 BLDG. ENV. WIDTH AT SETBACK: 41.6'

NOTE:
 AREAS DELINEATED AS VISION TRIANGLE AREAS
 SHALL HAVE NO PLANTINGS OVER TWO (2) FEET
 IN HEIGHT.

TYPICAL VISION CORNER DETAIL

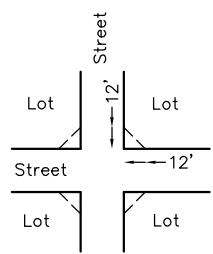

BSE1921\Final Plat\sales maps.dwg

LOT 101
 TERRAVESSA
 FITCHBURG LANDS, LLC

DATE 04/16/2020	PROJECT NO. BSE1921
SCALE 1"=40'	
IF THIS BAR DOES NOT MEASURE 1" THEN DRAWING IS NOT TO SCALE	

Burse
 surveying & engineering Inc.

2801 International Lane, Suite 101
 Madison, WI 53704 608.250.9263
 Fax: 608.250.9266
 email: mburse@bse-inc.net
 www.bursesurveyengr.com

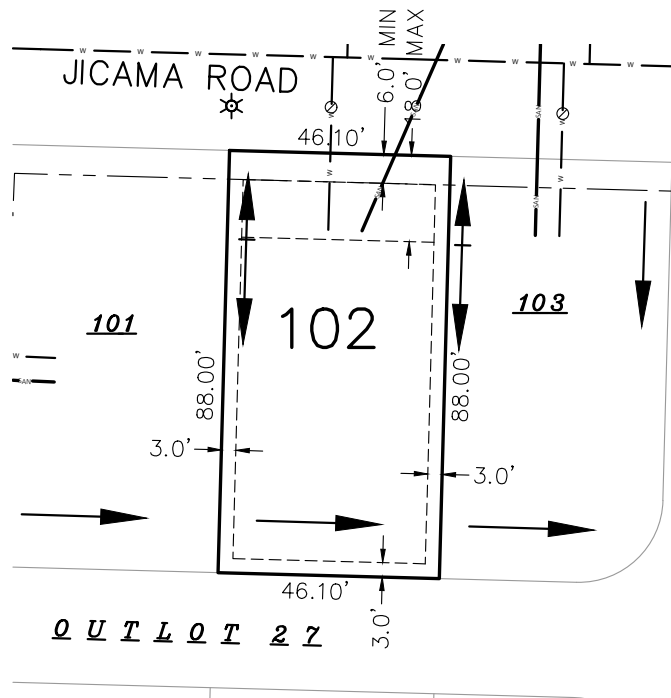

LEGEND

- SURFACE DRAINAGE SWALE DIRECTION
- BUILDING SETBACK LINE
- WATER SERVICE (PROPOSED)
- SANITARY LATERAL (PROPOSED)
- 6' ELECTRIC AND GAS LINES BELOW GRADE EASEMENT
- 10' UTILITY EASEMENT
- STREET LIGHT



TRANSECT ZONE: T4
 LOT SQUARE FOOTAGE: 4,057
 BLDG. ENV. WIDTH AT SETBACK: 40.1'

BSE1921\Final Plat\sales maps.dwg

LOT 102
 TERRAVESSA
 FITCHBURG LANDS, LLC

DATE 02-20-2018	PROJECT NO. BSE1921
SCALE 1" = 40'	
IF THIS BAR DOES NOT MEASURE 1" THEN DRAWING IS NOT TO SCALE	

Burse
 surveying & engineering LLC
 2801 International Lane, Suite 101
 Madison, WI 53704 608.250.9263
 Fax: 608.250.9266
 email: mburse@bse-inc.net
 www.bursesurveyengr.com

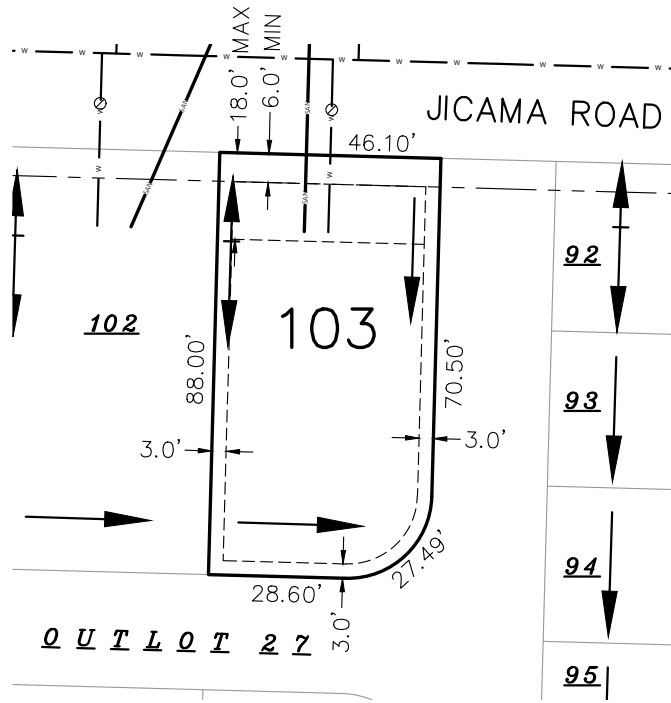

LEGEND

- SURFACE DRAINAGE SWALE DIRECTION
- BUILDING SETBACK LINE
- WATER SERVICE (PROPOSED)
- SANITARY LATERAL (PROPOSED)
- 6' ELECTRIC AND GAS LINES BELOW GRADE EASEMENT
- 10' UTILITY EASEMENT
- STREET LIGHT

TRANSECT ZONE: T4
 LOT SQUARE FOOTAGE: 3,991
 BLDG. ENV. WIDTH AT SETBACK: 40.1'

BSE1921\Final Plat\sales maps.dwg

LOT 103
 TERRAVESSA
 FITCHBURG LANDS, LLC

DATE 02-20-2018	PROJECT NO. BSE1921
SCALE 1" = 40'	
IF THIS BAR DOES NOT MEASURE 1" THEN DRAWING IS NOT TO SCALE	

Burse
 surveying & engineering LLC
 2801 International Lane, Suite 101
 Madison, WI 53704 608.250.9263
 Fax: 608.250.9266
 email: mburse@bse-inc.net
 www.bursesurveyengr.com

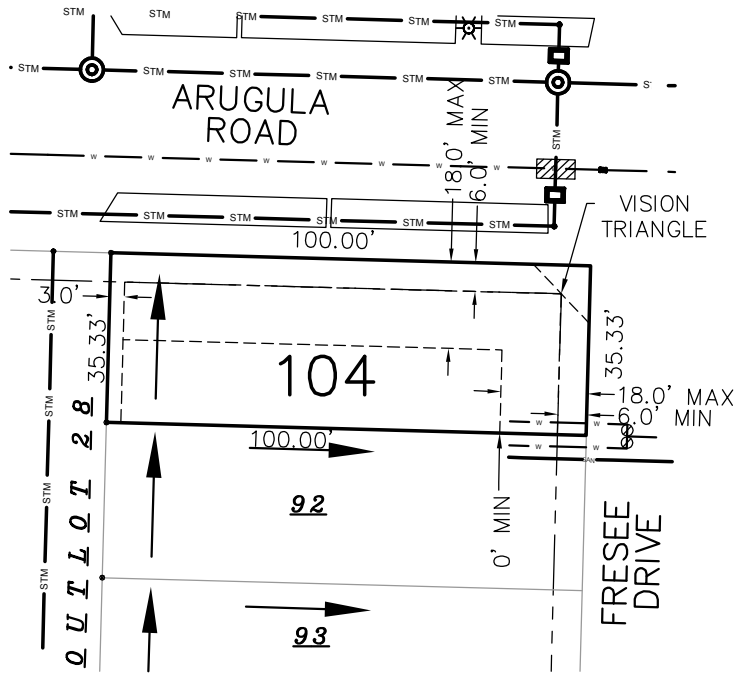

LEGEND

- SURFACE DRAINAGE SWALE DIRECTION
- BUILDING SETBACK LINE
- WATER SERVICE (PROPOSED)
- SANITARY LATERAL (PROPOSED)
- 6' ELECTRIC AND GAS LINES BELOW GRADE EASEMENT
- 10' UTILITY EASEMENT
- STREET LIGHT



TRANSECT ZONE: T4
 LOT SQUARE FOOTAGE: 3,533
 BLDG. ENV. WIDTH AT SETBACK: 29.3'

NOTE:
 AREAS DELINEATED AS VISION TRIANGLE AREAS
 SHALL HAVE NO PLANTINGS OVER TWO (2) FEET
 IN HEIGHT.

TYPICAL VISION CORNER DETAIL

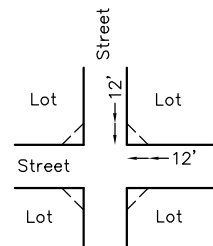

BSE1921\Final Plat\sales maps.dwg

LOT 104
 TERRAVESSA
 FITCHBURG LANDS, LLC

DATE: 04/16/2020 PROJECT NO.: BSE1921

SCALE: 1" = 40'

IF THIS BAR DOES NOT MEASURE 1" THEN DRAWING IS NOT TO SCALE

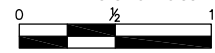

Burse
 surveying & engineering Inc.
 2801 International Lane, Suite 101
 Madison, WI 53704 608.250.9263
 Fax: 608.250.9266
 email: mburse@bse-inc.net
 www.bursesurveyengr.com

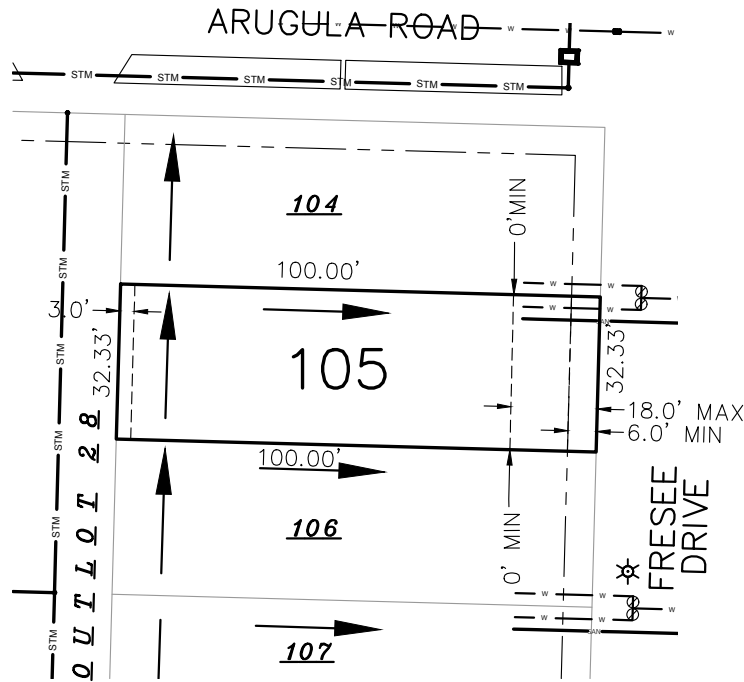

LEGEND

- SURFACE DRAINAGE SWALE DIRECTION
- BUILDING SETBACK LINE
- WATER SERVICE (PROPOSED)
- SANITARY LATERAL (PROPOSED)
- 6' ELECTRIC AND GAS LINES BELOW GRADE EASEMENT
- 10' UTILITY EASEMENT
- STREET LIGHT

TRANSECT ZONE: T4
 LOT SQUARE FOOTAGE: 3,233
 BLDG. ENV. WIDTH AT SETBACK: 32.3'

BSE1921\Final Plat\sales maps.dwg

LOT 105
 TERRAVESSA
 FITCHBURG LANDS, LLC

DATE 02-20-2018	PROJECT NO. BSE1921
SCALE 1" = 40'	
IF THIS BAR DOES NOT MEASURE 1" THEN DRAWING IS NOT TO SCALE	

Burse
 surveying & engineering LLC

2801 International Lane, Suite 101
 Madison, WI 53704 608.250.9263
 Fax: 608.250.9266
 email: mburse@bse-inc.net
 www.bursesurveyengr.com

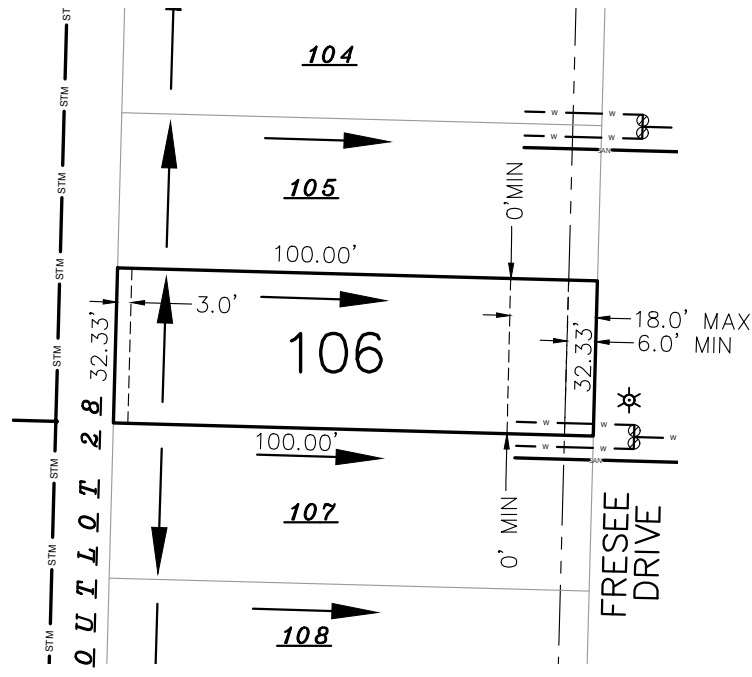

LEGEND

- SURFACE DRAINAGE SWALE DIRECTION
- BUILDING SETBACK LINE
- WATER SERVICE (PROPOSED)
- SANITARY LATERAL (PROPOSED)
- 6' ELECTRIC AND GAS LINES BELOW GRADE EASEMENT
- 10' UTILITY EASEMENT
- STREET LIGHT

TRANSECT ZONE: T4
 LOT SQUARE FOOTAGE: 3,233
 BLDG. ENV. WIDTH AT SETBACK: 32.3'

BSE1921\Final Plat\sales maps.dwg

LOT 106
 TERRAVESSA
 FITCHBURG LANDS, LLC

DATE 02-20-2018	PROJECT NO. BSE1921
SCALE 1" = 40'	
IF THIS BAR DOES NOT MEASURE 1" THEN DRAWING IS NOT TO SCALE	

Burse

surveying & engineering ^{LLC}

2801 International Lane, Suite 101
 Madison, WI 53704 608.250.9263
 Fax: 608.250.9266
 email: mburse@bse-inc.net
 www.bursesurveyengr.com

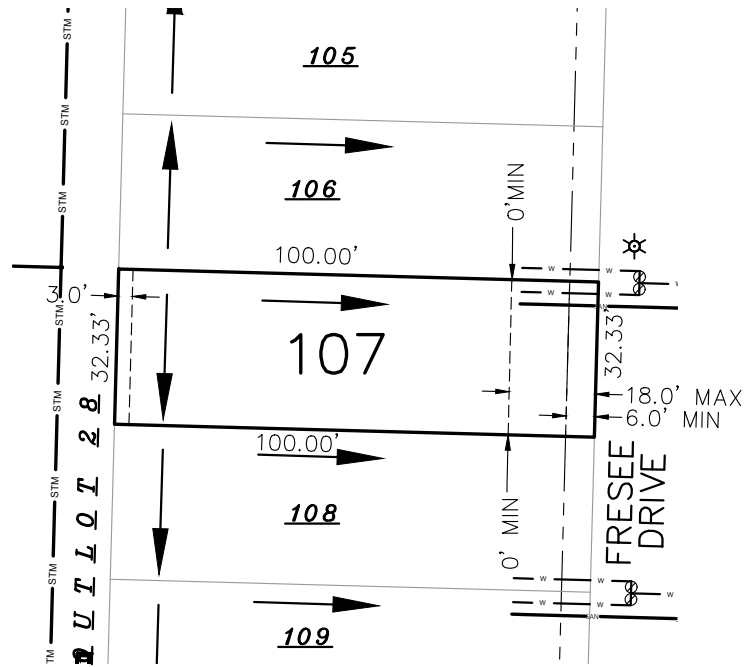

LEGEND

- SURFACE DRAINAGE SWALE DIRECTION
- BUILDING SETBACK LINE
- WATER SERVICE (PROPOSED)
- SANITARY LATERAL (PROPOSED)
- 6' ELECTRIC AND GAS LINES BELOW GRADE EASEMENT
- 10' UTILITY EASEMENT
- STREET LIGHT

TRANSECT ZONE: T4
 LOT SQUARE FOOTAGE: 3,233
 BLDG. ENV. WIDTH AT SETBACK: 32.3'

LOT 107
 TERRAVESSA
 FITCHBURG LANDS, LLC

DATE 02-20-2018	PROJECT NO. BSE1921
SCALE 1" = 40'	
IF THIS BAR DOES NOT MEASURE 1" THEN DRAWING IS NOT TO SCALE	

Burse
 surveying & engineering LLC

2801 International Lane, Suite 101
 Madison, WI 53704 608.250.9263
 Fax: 608.250.9266
 email: mburse@bse-inc.net
 www.bursesurveyengr.com

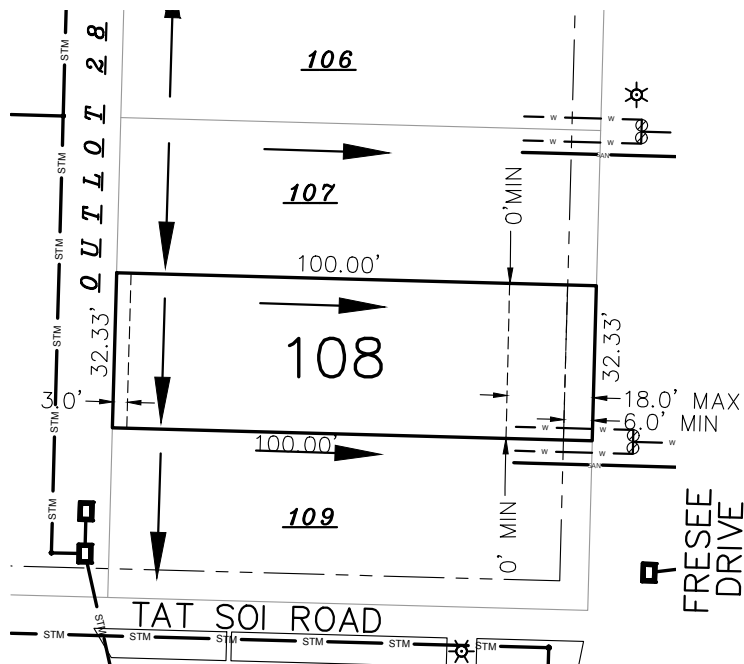

LEGEND

- SURFACE DRAINAGE SWALE DIRECTION
- BUILDING SETBACK LINE
- WATER SERVICE (PROPOSED)
- SANITARY LATERAL (PROPOSED)
- 6' ELECTRIC AND GAS LINES BELOW GRADE EASEMENT
- 10' UTILITY EASEMENT
- STREET LIGHT

TRANSECT ZONE: T4
 LOT SQUARE FOOTAGE: 3,233
 BLDG. ENV. WIDTH AT SETBACK: 32.3'

BSE1921\Final Plat\sales maps.dwg

LOT 108
 TERRAVESSA
 FITCHBURG LANDS, LLC

DATE 02-20-2018	PROJECT NO. BSE1921
SCALE 1" = 40'	
IF THIS BAR DOES NOT MEASURE 1" THEN DRAWING IS NOT TO SCALE	

Burse
 surveying & engineering LLC
 2801 International Lane, Suite 101
 Madison, WI 53704 608.250.9263
 Fax: 608.250.9266
 email: mburse@bse-inc.net
 www.bursesurveyengr.com

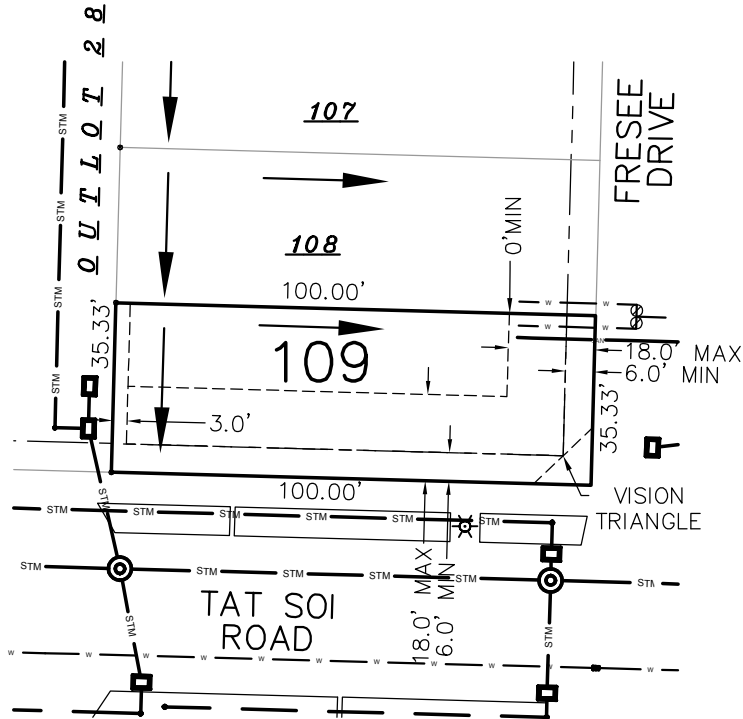

LEGEND

- ← SURFACE DRAINAGE SWALE DIRECTION
- BUILDING SETBACK LINE
- W— WATER SERVICE (PROPOSED)
- SAN— SANITARY LATERAL (PROPOSED)
- 6' ELECTRIC AND GAS LINES BELOW GRADE EASEMENT
- 10' UTILITY EASEMENT
- ☼ STREET LIGHT



TRANSECT ZONE: T4
 LOT SQUARE FOOTAGE: 3,533
 BLDG. ENV. WIDTH AT SETBACK: 29.3'

NOTE:
 AREAS DELINEATED AS VISION TRIANGLE AREAS
 SHALL HAVE NO PLANTINGS OVER TWO (2) FEET
 IN HEIGHT.

TYPICAL VISION CORNER DETAIL

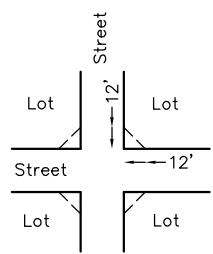

BSE1921\Final Plat\sales maps.dwg

LOT 109
 TERRAVESSA
 FITCHBURG LANDS, LLC

DATE 04/16/2020	PROJECT NO. BSE1921
SCALE 1"=40'	
IF THIS BAR DOES NOT MEASURE 1" THEN DRAWING IS NOT TO SCALE	

Burse
 surveying & engineering Inc.
 2801 International Lane, Suite 101
 Madison, WI 53704 608.250.9263
 Fax: 608.250.9266
 email: mburse@bse-inc.net
 www.bursesurveyengr.com

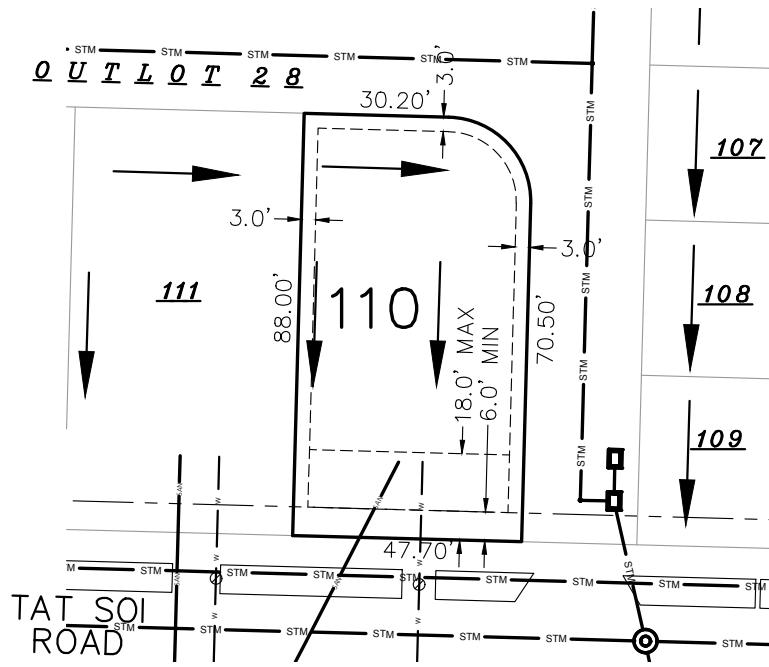

LEGEND

- SURFACE DRAINAGE SWALE DIRECTION
- BUILDING SETBACK LINE
- WATER SERVICE (PROPOSED)
- SANITARY LATERAL (PROPOSED)
- 6' ELECTRIC AND GAS LINES BELOW GRADE EASEMENT
- 10' UTILITY EASEMENT
- STREET LIGHT

TRANSECT ZONE: T4
 LOT SQUARE FOOTAGE: 4,132
 BLDG. ENV. WIDTH AT SETBACK: 41.70'

BSE1921\Final Plat\sales maps.dwg

LOT 110
 TERRAVESSA
 FITCHBURG LANDS, LLC

DATE 02-20-2018	PROJECT NO. BSE1921
SCALE 1" = 40'	
IF THIS BAR DOES NOT MEASURE 1" THEN DRAWING IS NOT TO SCALE	

Burse
 surveying & engineering LLC

2801 International Lane, Suite 101
 Madison, WI 53704 608.250.9263
 Fax: 608.250.9266
 email: mburse@bse-inc.net
 www.bursesurveyengr.com

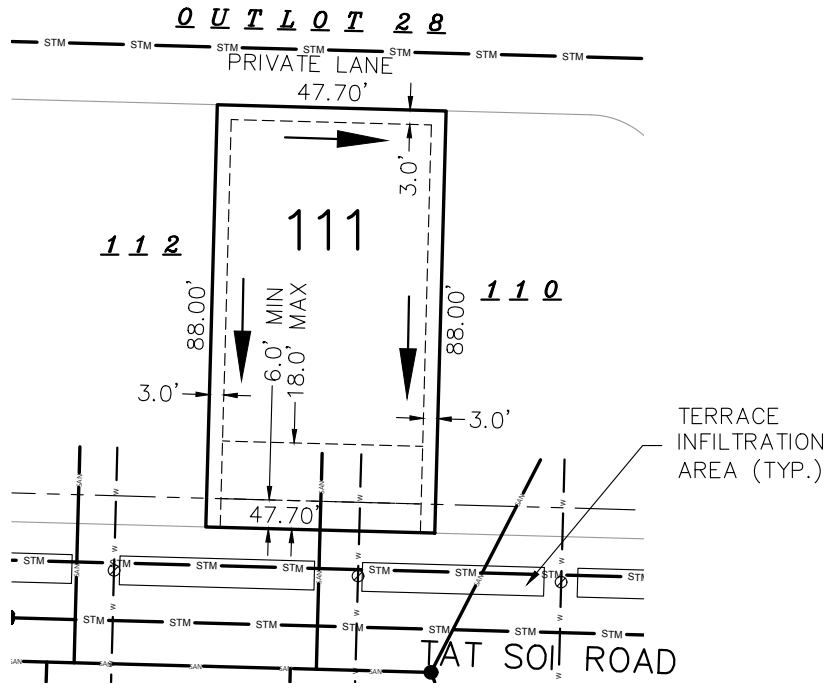

LEGEND

- SURFACE DRAINAGE SWALE DIRECTION
- BUILDING SETBACK LINE
- WATER SERVICE (PROPOSED)
- SANITARY LATERAL (PROPOSED)
- 6' ELECTRIC AND GAS LINES BELOW GRADE EASEMENT
- 10' UTILITY EASEMENT
- STREET LIGHT

TRANSECT ZONE: T4
 LOT SQUARE FOOTAGE: 4,198
 BLDG. ENV. WIDTH AT SETBACK: 41.7'

BSE1921\Final Plat\sales maps.dwg

LOT 111
 TERRAVESSA
 FITCHBURG LANDS, LLC

DATE 02-20-2018	PROJECT NO. BSE1921
SCALE 1" = 40'	
IF THIS BAR DOES NOT MEASURE 1" THEN DRAWING IS NOT TO SCALE	

Burse
 surveying & engineering LLC
 2801 International Lane, Suite 101
 Madison, WI 53704 608.250.9263
 Fax: 608.250.9266
 email: mburse@bse-inc.net
 www.bursesurveyengr.com

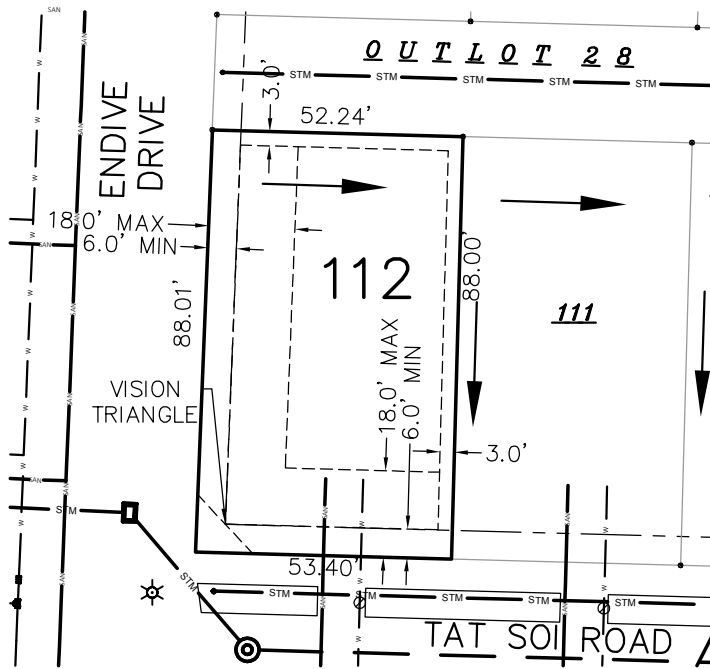

LEGEND

- SURFACE DRAINAGE SWALE DIRECTION
- BUILDING SETBACK LINE
- WATER SERVICE (PROPOSED)
- SANITARY LATERAL (PROPOSED)
- 6' ELECTRIC AND GAS LINES BELOW GRADE EASEMENT
- 10' UTILITY EASEMENT
- STREET LIGHT



TRANSECT ZONE: T4
 LOT SQUARE FOOTAGE: 4,648
 BLDG. ENV. WIDTH AT SETBACK: 44.3'

NOTE:
 AREAS DELINEATED AS VISION TRIANGLE AREAS
 SHALL HAVE NO PLANTINGS OVER TWO (2) FEET
 IN HEIGHT.

TYPICAL VISION CORNER DETAIL

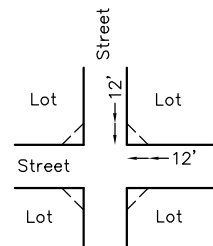

BSE1921\Final Plat\sales maps.dwg

LOT 112
 TERRAVESSA
 FITCHBURG LANDS, LLC

DATE: 04/16/2020
 PROJECT NO.: BSE1921

SCALE
 1"=40'

IF THIS BAR DOES NOT MEASURE 1"
 THEN DRAWING IS NOT TO SCALE

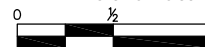

Burse
 surveying & engineering Inc.
 2801 International Lane, Suite 101
 Madison, WI 53704 608.250.9263
 Fax: 608.250.9266
 email: mburse@bse-inc.net
 www.bursesurveyengr.com

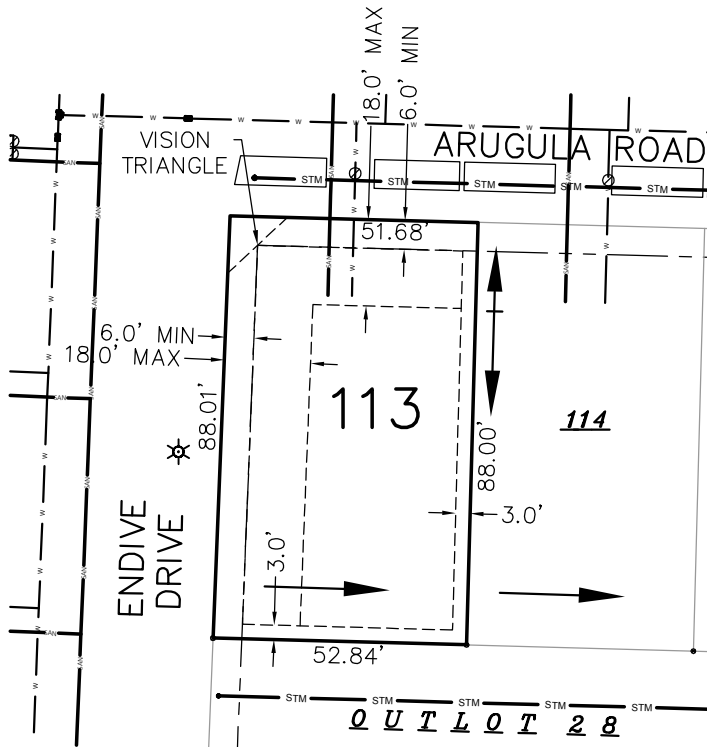

LEGEND

- SURFACE DRAINAGE SWALE DIRECTION
- BUILDING SETBACK LINE
- WATER SERVICE (PROPOSED)
- SANITARY LATERAL (PROPOSED)
- 6' ELECTRIC AND GAS LINES BELOW GRADE EASEMENT
- 10' UTILITY EASEMENT
- STREET LIGHT



TRANSECT ZONE: T4
 LOT SQUARE FOOTAGE: 4,599
 BLDG. ENV. WIDTH AT SETBACK: 42.68'

NOTE:
 AREAS DELINEATED AS VISION TRIANGLE AREAS
 SHALL HAVE NO PLANTINGS OVER TWO (2) FEET
 IN HEIGHT.

TYPICAL VISION CORNER DETAIL

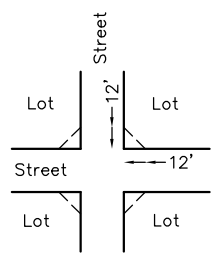

BSE1921\Final Plat\sales maps.dwg

LOT 113
 TERRAVESSA
 FITCHBURG LANDS, LLC

DATE 04/16/2020	PROJECT NO. BSE1921
SCALE 1"=40'	
IF THIS BAR DOES NOT MEASURE 1" THEN DRAWING IS NOT TO SCALE	

Burse
 surveying & engineering Inc.

2801 International Lane, Suite 101
 Madison, WI 53704 608.250.9263
 Fax: 608.250.9266
 email: mburse@bse-inc.net
 www.bursesurveyengr.com

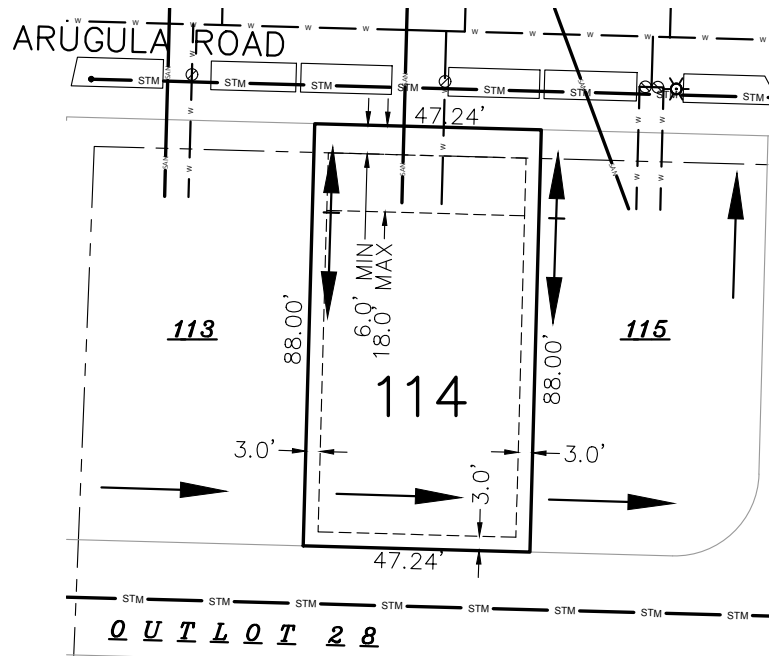

LEGEND

- SURFACE DRAINAGE SWALE DIRECTION
- BUILDING SETBACK LINE
- WATER SERVICE (PROPOSED)
- SANITARY LATERAL (PROPOSED)
- 6' ELECTRIC AND GAS LINES BELOW GRADE EASEMENT
- 10' UTILITY EASEMENT
- STREET LIGHT

TRANSECT ZONE: T4
 LOT SQUARE FOOTAGE: 4,157
 BLDG. ENV. WIDTH AT SETBACK: 36.24'

BSE1921\Final Plat\sales maps.dwg

LOT 114
 TERRAVESSA
 FITCHBURG LANDS, LLC

DATE 12-03-2018	PROJECT NO. BSE1921
SCALE 1" = 40'	
IF THIS BAR DOES NOT MEASURE 1" THEN DRAWING IS NOT TO SCALE	

Burse
 surveying & engineering LLC

2801 International Lane, Suite 101
 Madison, WI 53704 608.250.9263
 Fax: 608.250.9266
 email: mburse@bse-inc.net
 www.bursesurveyengr.com

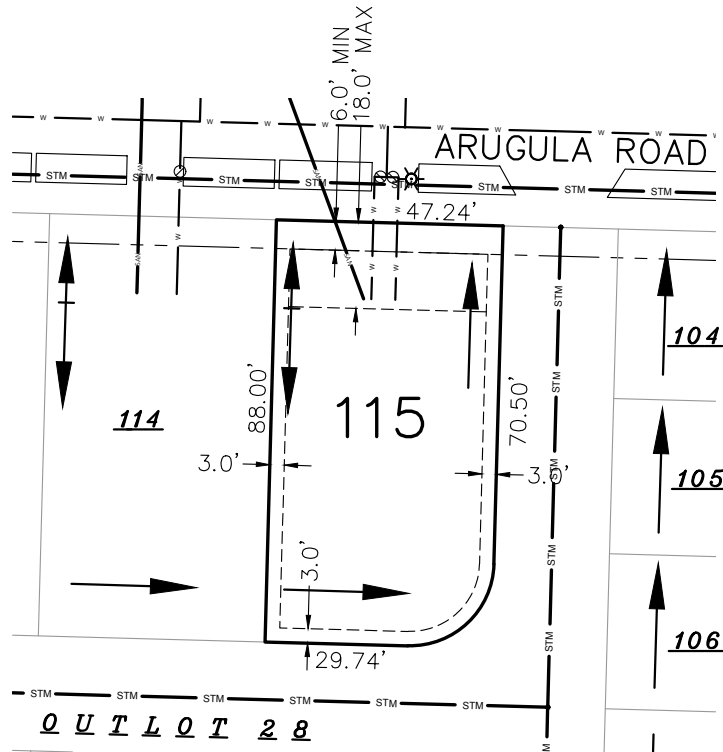

LEGEND

- SURFACE DRAINAGE SWALE DIRECTION
- BUILDING SETBACK LINE
- WATER SERVICE (PROPOSED)
- SANITARY LATERAL (PROPOSED)
- 6' ELECTRIC AND GAS LINES BELOW GRADE EASEMENT
- 10' UTILITY EASEMENT
- STREET LIGHT



TRANSECT ZONE: T4
 LOT SQUARE FOOTAGE: 4,091
 BLDG. ENV. WIDTH AT SETBACK: 41.24'

BSE1921\Final Plat\sales maps.dwg

LOT 115
 TERRAVESSA
 FITCHBURG LANDS, LLC

DATE 12-03-2018	PROJECT NO. BSE1921
SCALE 1" = 40'	
IF THIS BAR DOES NOT MEASURE 1" THEN DRAWING IS NOT TO SCALE	

Burse
 surveying & engineering LLC

2801 International Lane, Suite 101
 Madison, WI 53704 608.250.9263
 Fax: 608.250.9266
 email: mburse@bse-inc.net
 www.bursesurveyengr.com

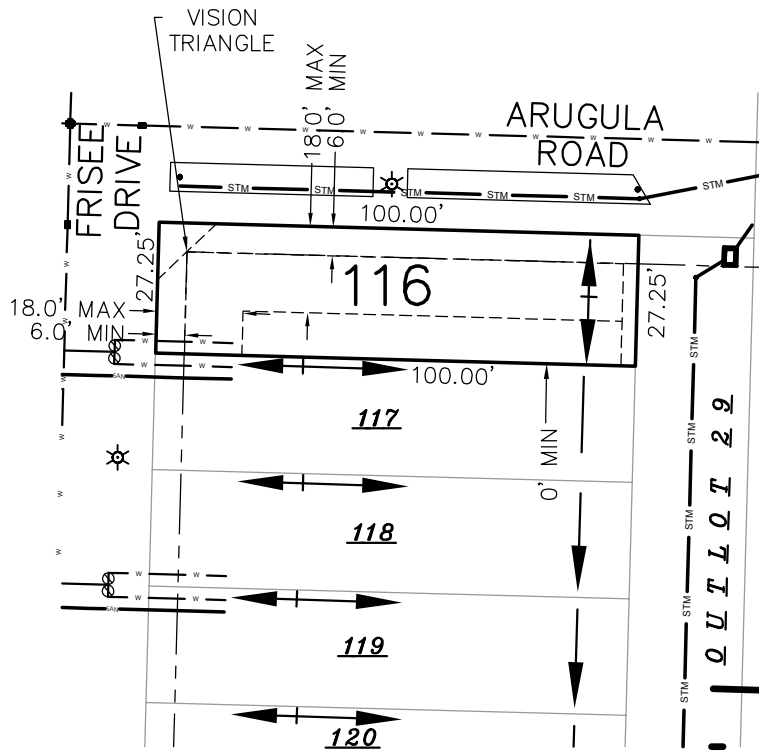

LEGEND

- SURFACE DRAINAGE SWALE DIRECTION
- BUILDING SETBACK LINE
- WATER SERVICE (PROPOSED)
- SANITARY LATERAL (PROPOSED)
- 6' ELECTRIC AND GAS LINES BELOW GRADE EASEMENT
- 10' UTILITY EASEMENT
- STREET LIGHT



TRANSECT ZONE: T4
 LOT SQUARE FOOTAGE: 2,725
 BLDG. ENV. WIDTH AT SETBACK: 21.2'

NOTE:
 AREAS DELINEATED AS VISION TRIANGLE AREAS
 SHALL HAVE NO PLANTINGS OVER TWO (2) FEET
 IN HEIGHT.

TYPICAL VISION CORNER DETAIL

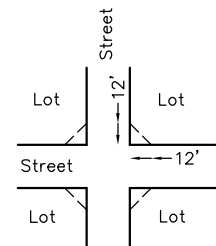

BSE1921\Final Plat\sales maps.dwg

LOT 116
 TERRAVESSA
 FITCHBURG LANDS, LLC

DATE: 04/16/2020 PROJECT NO.: BSE1921

SCALE: 1"=40'

IF THIS BAR DOES NOT MEASURE 1" THEN DRAWING IS NOT TO SCALE

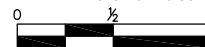

Burse
 surveying & engineering Inc.
 2801 International Lane, Suite 101
 Madison, WI 53704 608.250.9263
 Fax: 608.250.9266
 email: mburse@bse-inc.net
 www.bursesurveyengr.com

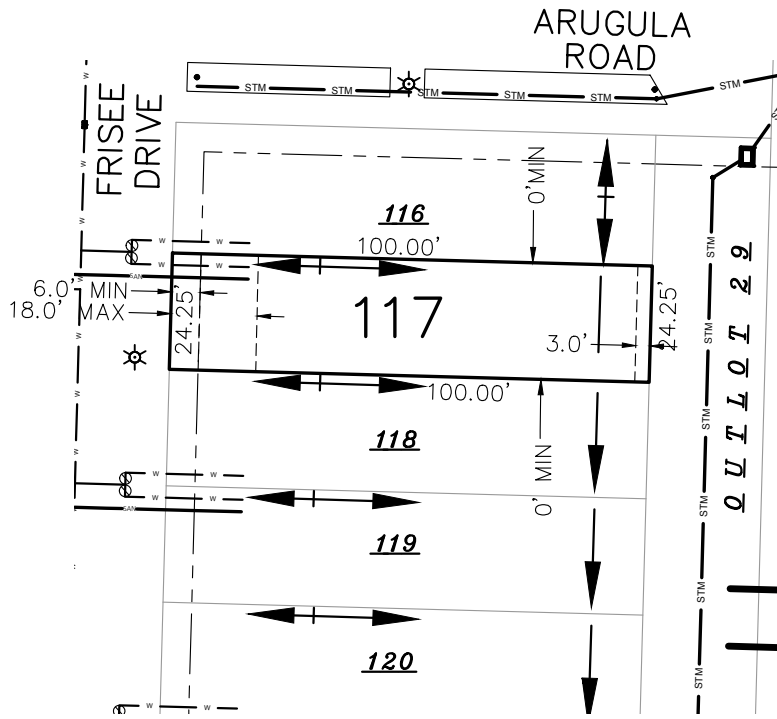

LEGEND

- SURFACE DRAINAGE SWALE DIRECTION
- BUILDING SETBACK LINE
- WATER SERVICE (PROPOSED)
- SANITARY LATERAL (PROPOSED)
- 6' ELECTRIC AND GAS LINES BELOW GRADE EASEMENT
- 10' UTILITY EASEMENT
- STREET LIGHT

TRANSECT ZONE: T4
 LOT SQUARE FOOTAGE: 2,425
 BLDG. ENV. WIDTH AT SETBACK: 24.25'

LOT 117
 TERRAVESSA
 FITCHBURG LANDS, LLC

DATE 12-03-2018	PROJECT NO. BSE1921
SCALE 1" = 40'	
IF THIS BAR DOES NOT MEASURE 1" THEN DRAWING IS NOT TO SCALE	

Burse
 surveying & engineering LLC
 2801 International Lane, Suite 101
 Madison, WI 53704 608.250.9263
 Fax: 608.250.9266
 email: mburse@bse-inc.net
 www.bursesurveyengr.com

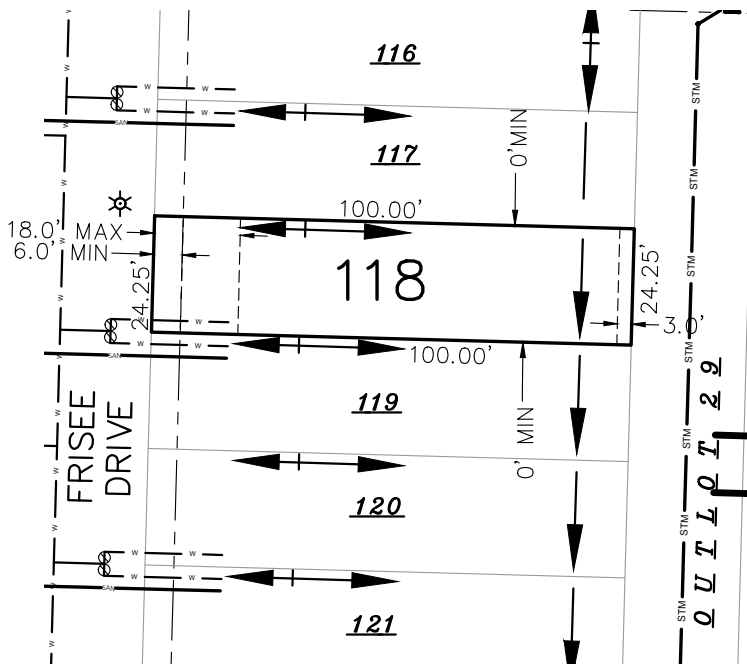

LEGEND

- SURFACE DRAINAGE SWALE DIRECTION
- BUILDING SETBACK LINE
- WATER SERVICE (PROPOSED)
- SANITARY LATERAL (PROPOSED)
- 6' ELECTRIC AND GAS LINES BELOW GRADE EASEMENT
- 10' UTILITY EASEMENT
- STREET LIGHT



TRANSECT ZONE: T4
 LOT SQUARE FOOTAGE: 2,425
 BLDG. ENV. WIDTH AT SETBACK: 24.25'

LOT 118
 TERRAVESSA
 FITCHBURG LANDS, LLC

DATE 12-03-2018	PROJECT NO. BSE1921
SCALE 1" = 40'	
IF THIS BAR DOES NOT MEASURE 1" THEN DRAWING IS NOT TO SCALE	

Burse
 surveying & engineering LLC
 2801 International Lane, Suite 101
 Madison, WI 53704 608.250.9263
 Fax: 608.250.9266
 email: mburse@bse-inc.net
 www.bursesurveyengr.com

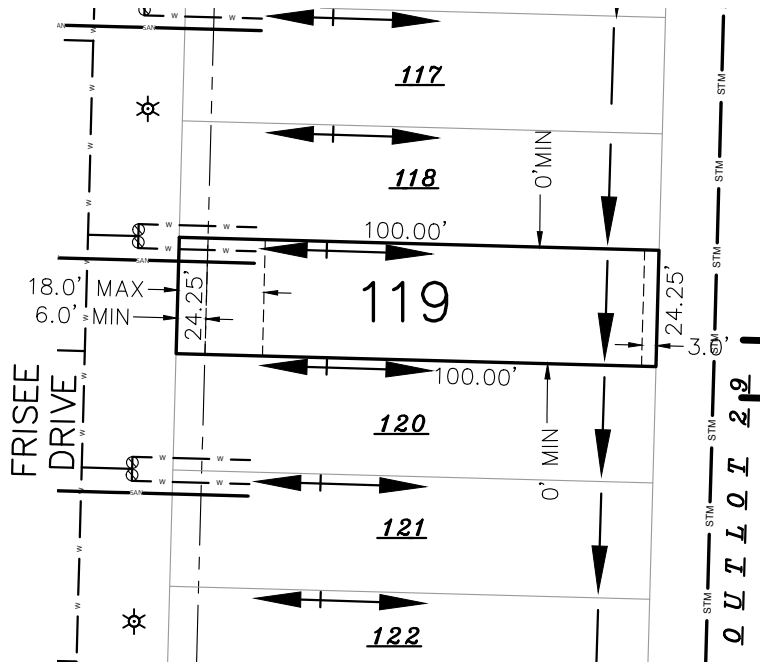

LEGEND

- SURFACE DRAINAGE SWALE DIRECTION
- BUILDING SETBACK LINE
- WATER SERVICE (PROPOSED)
- SANITARY LATERAL (PROPOSED)
- 6' ELECTRIC AND GAS LINES BELOW GRADE EASEMENT
- 10' UTILITY EASEMENT
- STREET LIGHT

TRANSECT ZONE: T4
 LOT SQUARE FOOTAGE: 2,425
 BLDG. ENV. WIDTH AT SETBACK: 24.25'

LOT 119
 TERRAVESSA
 FITCHBURG LANDS, LLC

DATE 12-03-2018	PROJECT NO. BSE1921
SCALE 1" = 40'	
IF THIS BAR DOES NOT MEASURE 1" THEN DRAWING IS NOT TO SCALE	

Burse
 surveying & engineering LLC
 2801 International Lane, Suite 101
 Madison, WI 53704 608.250.9263
 Fax: 608.250.9266
 email: mburse@bse-inc.net
 www.bursesurveyengr.com

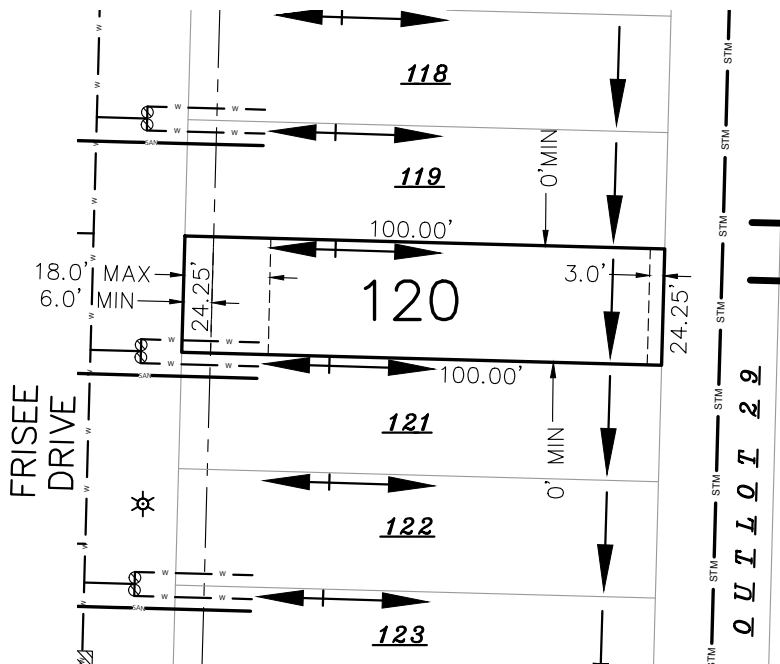

LEGEND

- SURFACE DRAINAGE SWALE DIRECTION
- BUILDING SETBACK LINE
- WATER SERVICE (PROPOSED)
- SANITARY LATERAL (PROPOSED)
- 6' ELECTRIC AND GAS LINES BELOW GRADE EASEMENT
- 10' UTILITY EASEMENT
- STREET LIGHT

TRANSECT ZONE: T4
 LOT SQUARE FOOTAGE: 2,425
 BLDG. ENV. WIDTH AT SETBACK: 24.25'

BSE1921\Final Plat\sales maps.dwg

LOT 120
 TERRAVESSA
 FITCHBURG LANDS, LLC

DATE 12-03-2018	PROJECT NO. BSE1921
SCALE 1" = 40'	
IF THIS BAR DOES NOT MEASURE 1" THEN DRAWING IS NOT TO SCALE	

Burse
 surveying & engineering LLC
 2801 International Lane, Suite 101
 Madison, WI 53704 608.250.9263
 Fax: 608.250.9266
 email: mburse@bse-inc.net
 www.bursesurveyengr.com

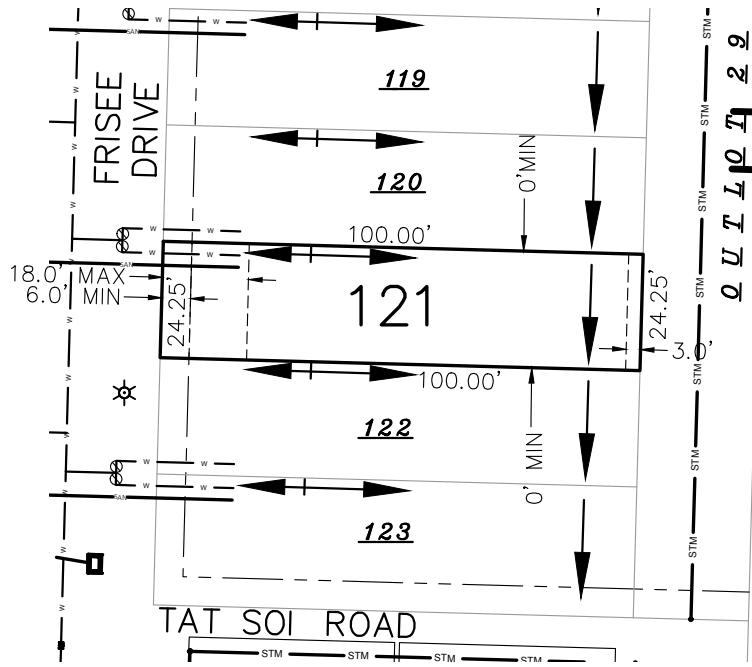

LEGEND

- SURFACE DRAINAGE SWALE DIRECTION
- BUILDING SETBACK LINE
- WATER SERVICE (PROPOSED)
- SANITARY LATERAL (PROPOSED)
- 6' ELECTRIC AND GAS LINES BELOW GRADE EASEMENT
- 10' UTILITY EASEMENT
- STREET LIGHT

TRANSECT ZONE: T4
 LOT SQUARE FOOTAGE: 2,425
 BLDG. ENV. WIDTH AT SETBACK: 24.24'

BSE1921\Final Plat\sales maps.dwg

LOT 121
 TERRAVESSA
 FITCHBURG LANDS, LLC

DATE 12-03-2018	PROJECT NO. BSE1921
SCALE 1" = 40'	
IF THIS BAR DOES NOT MEASURE 1" THEN DRAWING IS NOT TO SCALE	

Burse
 surveying & engineering LLC

2801 International Lane, Suite 101
 Madison, WI 53704 608.250.9263
 Fax: 608.250.9266
 email: mburse@bse-inc.net
 www.bursesurveyengr.com

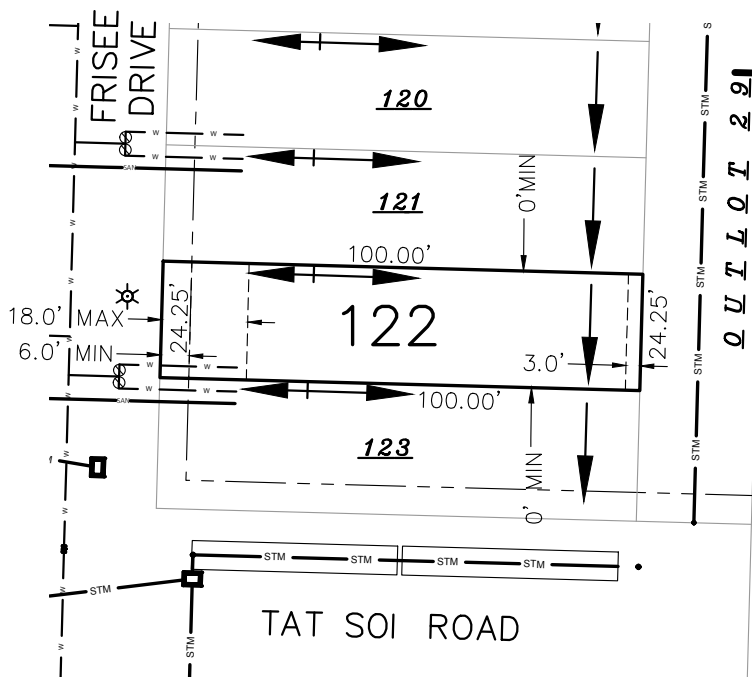

LEGEND

- SURFACE DRAINAGE SWALE DIRECTION
- BUILDING SETBACK LINE
- WATER SERVICE (PROPOSED)
- SANITARY LATERAL (PROPOSED)
- 6' ELECTRIC AND GAS LINES BELOW GRADE EASEMENT
- 10' UTILITY EASEMENT
- STREET LIGHT

TRANSECT ZONE: T4
 LOT SQUARE FOOTAGE: 2,425
 BLDG. ENV. WIDTH AT SETBACK: 24.25'



LOT 122
 TERRAVESSA
 FITCHBURG LANDS, LLC

DATE 12-03-2018	PROJECT NO. BSE1921
SCALE 1" = 40'	
IF THIS BAR DOES NOT MEASURE 1" THEN DRAWING IS NOT TO SCALE	

Burse
 surveying & engineering LLC
 2801 International Lane, Suite 101
 Madison, WI 53704 608.250.9263
 Fax: 608.250.9266
 email: mburse@bse-inc.net
 www.bursesurveyengr.com

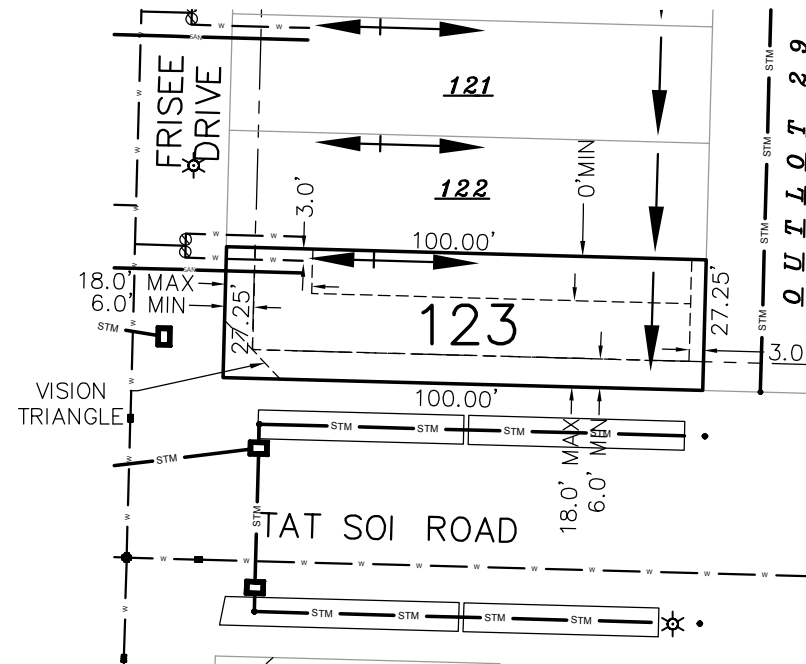

LEGEND

- SURFACE DRAINAGE SWALE DIRECTION
- BUILDING SETBACK LINE
- WATER SERVICE (PROPOSED)
- SANITARY LATERAL (PROPOSED)
- 6' ELECTRIC AND GAS LINES BELOW GRADE EASEMENT
- 10' UTILITY EASEMENT
- STREET LIGHT



TRANSECT ZONE: T4
 LOT SQUARE FOOTAGE: 2,725
 BLDG. ENV. WIDTH AT SETBACK: 21.2'

NOTE:
 AREAS DELINEATED AS VISION TRIANGLE AREAS
 SHALL HAVE NO PLANTINGS OVER TWO (2) FEET
 IN HEIGHT.

TYPICAL VISION CORNER DETAIL

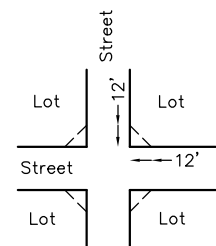

BSE1921\Final Plat\sales maps.dwg

LOT 123
 TERRAVESSA
 FITCHBURG LANDS, LLC

DATE: 04/16/2020
 PROJECT NO.: BSE1921

SCALE: 1" = 40'

IF THIS BAR DOES NOT MEASURE 1" THEN DRAWING IS NOT TO SCALE

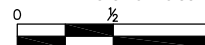

Burse
 surveying & engineering Inc.
 2801 International Lane, Suite 101
 Madison, WI 53704 608.250.9263
 Fax: 608.250.9266
 email: mburse@bse-inc.net
 www.bursesurveyengr.com

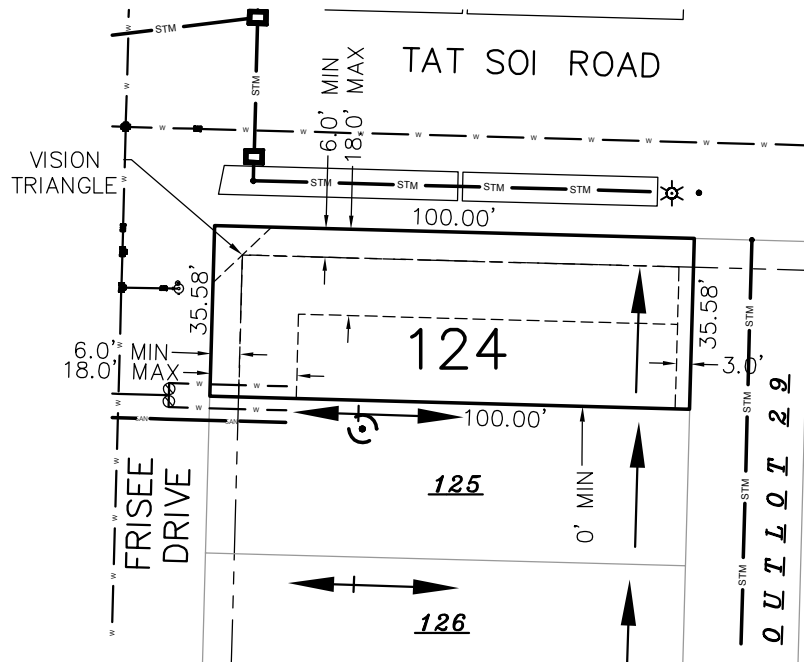

LEGEND

- SURFACE DRAINAGE SWALE DIRECTION
- BUILDING SETBACK LINE
- WATER SERVICE (PROPOSED)
- SANITARY LATERAL (PROPOSED)
- 6' ELECTRIC AND GAS LINES BELOW GRADE EASEMENT
- 10' UTILITY EASEMENT
- STREET LIGHT



TRANSECT ZONE: T4
 LOT SQUARE FOOTAGE: 3,558
 BLDG. ENV. WIDTH AT SETBACK: 29.6'

NOTE:
 AREAS DELINEATED AS VISION TRIANGLE AREAS
 SHALL HAVE NO PLANTINGS OVER TWO (2) FEET
 IN HEIGHT.

TYPICAL VISION CORNER DETAIL

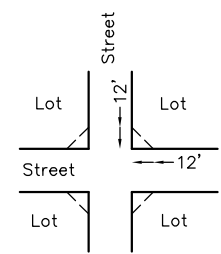

BSE1921\Final Plat\sales maps.dwg

LOT 124
 TERRAVESSA
 FITCHBURG LANDS, LLC

DATE 04/16/2020	PROJECT NO. BSE1921
SCALE 1"=40'	
IF THIS BAR DOES NOT MEASURE 1" THEN DRAWING IS NOT TO SCALE	

Burse
 surveying & engineering Inc.

2801 International Lane, Suite 101
 Madison, WI 53704 608.250.9263
 Fax: 608.250.9266
 email: mburse@bse-inc.net
 www.bursesurveyengr.com

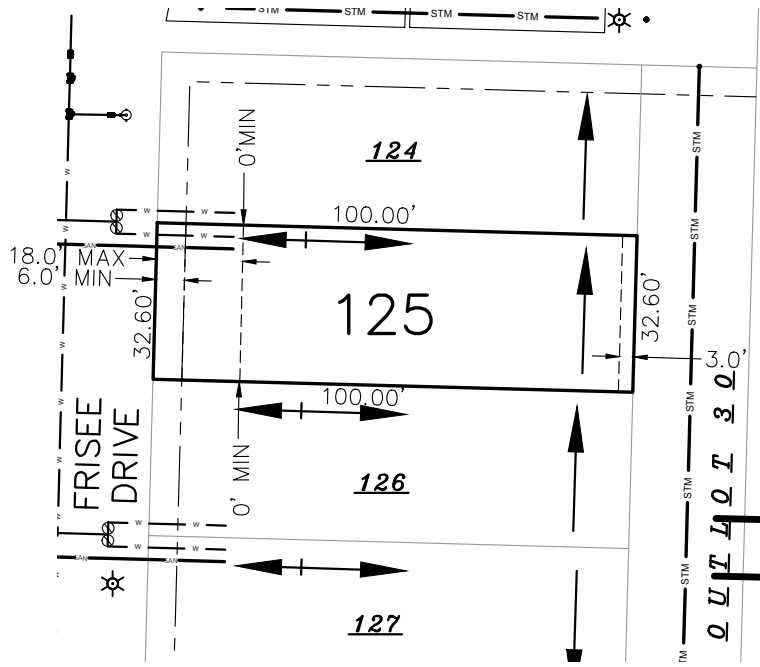

LEGEND

- SURFACE DRAINAGE SWALE DIRECTION
- BUILDING SETBACK LINE
- WATER SERVICE (PROPOSED)
- SANITARY LATERAL (PROPOSED)
- 6' ELECTRIC AND GAS LINES BELOW GRADE EASEMENT
- 10' UTILITY EASEMENT
- STREET LIGHT

TRANSECT ZONE: T4
 LOT SQUARE FOOTAGE: 3,260
 BLDG. ENV. WIDTH AT SETBACK: 32.6'

BSE1921\Final Plat\sales maps.dwg

LOT 125
 TERRAVESSA
 FITCHBURG LANDS, LLC

DATE 12-03-2018	PROJECT NO. BSE1921
SCALE 1" = 40'	
IF THIS BAR DOES NOT MEASURE 1" THEN DRAWING IS NOT TO SCALE	

Burse
 surveying & engineering LLC

2801 International Lane, Suite 101
 Madison, WI 53704 608.250.9263
 Fax: 608.250.9266
 email: mburse@bse-inc.net
 www.bursesurveyengr.com

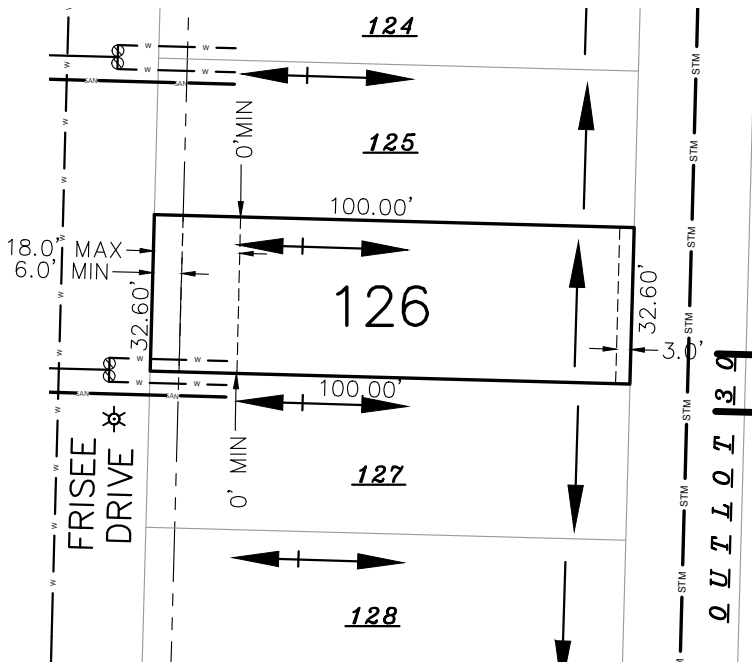

LEGEND

- SURFACE DRAINAGE SWALE DIRECTION
- BUILDING SETBACK LINE
- WATER SERVICE (PROPOSED)
- SANITARY LATERAL (PROPOSED)
- 6' ELECTRIC AND GAS LINES BELOW GRADE EASEMENT
- 10' UTILITY EASEMENT
- STREET LIGHT

TRANSECT ZONE: T4
 LOT SQUARE FOOTAGE: 3,260
 BLDG. ENV. WIDTH AT SETBACK: 32.6'

BSE1921\Final Plat\sales maps.dwg

LOT 126
 TERRAVESSA
 FITCHBURG LANDS, LLC

DATE 12-03-2018	PROJECT NO. BSE1921
SCALE 1" = 40'	
IF THIS BAR DOES NOT MEASURE 1" THEN DRAWING IS NOT TO SCALE	

Burse
 surveying & engineering LLC
 2801 International Lane, Suite 101
 Madison, WI 53704 608.250.9263
 Fax: 608.250.9266
 email: mburse@bse-inc.net
 www.bursesurveyengr.com

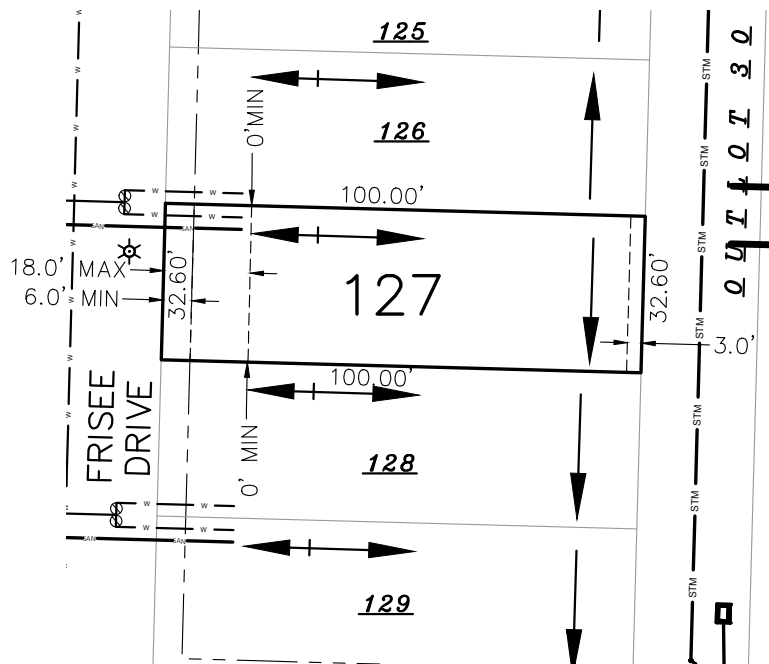

LEGEND

- SURFACE DRAINAGE SWALE DIRECTION
- BUILDING SETBACK LINE
- WATER SERVICE (PROPOSED)
- SANITARY LATERAL (PROPOSED)
- 6' ELECTRIC AND GAS LINES BELOW GRADE EASEMENT
- 10' UTILITY EASEMENT
- STREET LIGHT



TRANSECT ZONE: T4
 LOT SQUARE FOOTAGE: 3,260
 BLDG. ENV. WIDTH AT SETBACK: 32.6'

LOT 127
 TERRAVESSA
 FITCHBURG LANDS, LLC

DATE 12-03-2018	PROJECT NO. BSE1921
SCALE 1" = 40'	
IF THIS BAR DOES NOT MEASURE 1" THEN DRAWING IS NOT TO SCALE	

Burse
 surveying & engineering LLC
 2801 International Lane, Suite 101
 Madison, WI 53704 608.250.9263
 Fax: 608.250.9266
 email: mburse@bse-inc.net
 www.bursesurveyengr.com

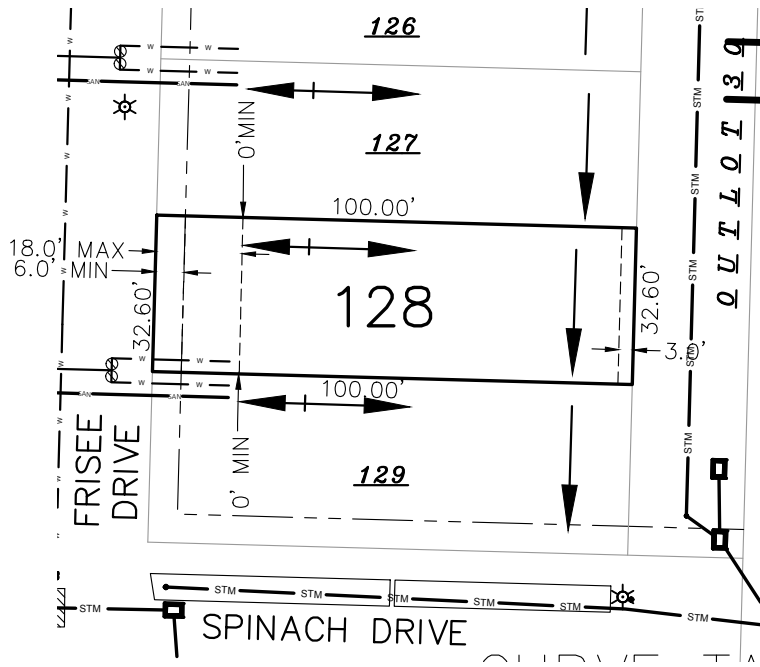

LEGEND

- SURFACE DRAINAGE SWALE DIRECTION
- BUILDING SETBACK LINE
- WATER SERVICE (PROPOSED)
- SANITARY LATERAL (PROPOSED)
- 6' ELECTRIC AND GAS LINES BELOW GRADE EASEMENT
- 10' UTILITY EASEMENT
- STREET LIGHT

TRANSECT ZONE: T4
 LOT SQUARE FOOTAGE: 3,260
 BLDG. ENV. WIDTH AT SETBACK: 32.6'

BSE1921\Final Plat\sales maps.dwg

LOT 128
 TERRAVESSA
 FITCHBURG LANDS, LLC

DATE 12-03-2018	PROJECT NO. BSE1921
SCALE 1" = 40'	
IF THIS BAR DOES NOT MEASURE 1" THEN DRAWING IS NOT TO SCALE	

Burse
 surveying & engineering ^{LLC}
 2801 International Lane, Suite 101
 Madison, WI 53704 608.250.9263
 Fax: 608.250.9266
 email: mburse@bse-inc.net
 www.bursesurveyengr.com

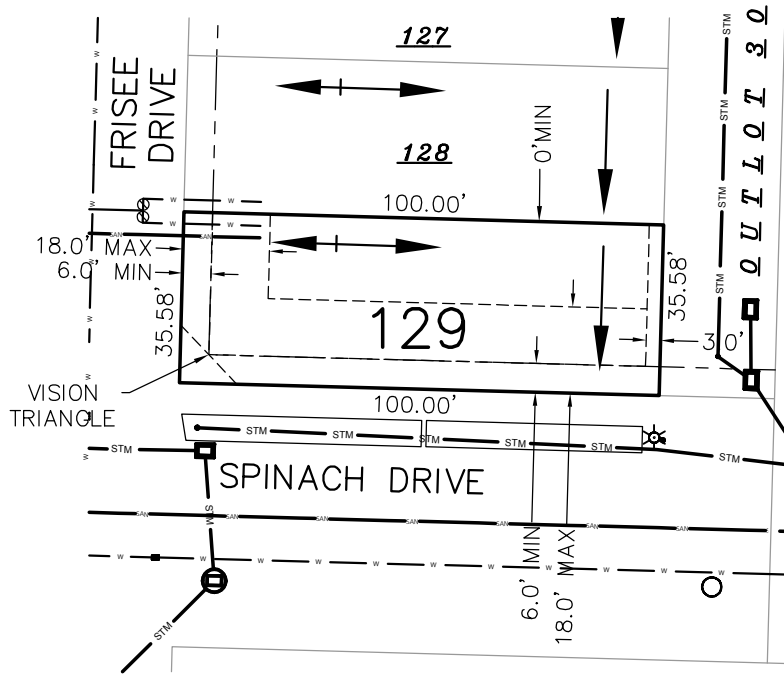

LEGEND

- SURFACE DRAINAGE SWALE DIRECTION
- BUILDING SETBACK LINE
- WATER SERVICE (PROPOSED)
- SANITARY LATERAL (PROPOSED)
- 6' ELECTRIC AND GAS LINES BELOW GRADE EASEMENT
- 10' UTILITY EASEMENT
- STREET LIGHT



TRANSECT ZONE: T4
 LOT SQUARE FOOTAGE: 3,558
 BLDG. ENV. WIDTH AT SETBACK: 29.6'

NOTE:
 AREAS DELINEATED AS VISION TRIANGLE AREAS
 SHALL HAVE NO PLANTINGS OVER TWO (2) FEET
 IN HEIGHT.

TYPICAL VISION CORNER DETAIL

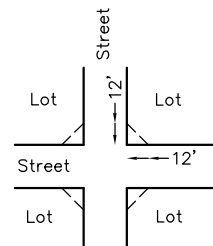

BSE1921\Final Plat\sales maps.dwg

LOT 129
 TERRAVESSA
 FITCHBURG LANDS, LLC

DATE: 04/16/2020 PROJECT NO.: BSE1921

SCALE
 1"=40'

IF THIS BAR DOES NOT MEASURE 1"
 THEN DRAWING IS NOT TO SCALE

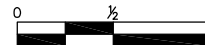

Burse
 surveying & engineering Inc.
 2801 International Lane, Suite 101
 Madison, WI 53704 608.250.9263
 Fax: 608.250.9266
 email: mburse@bse-inc.net
 www.bursesurveyengr.com

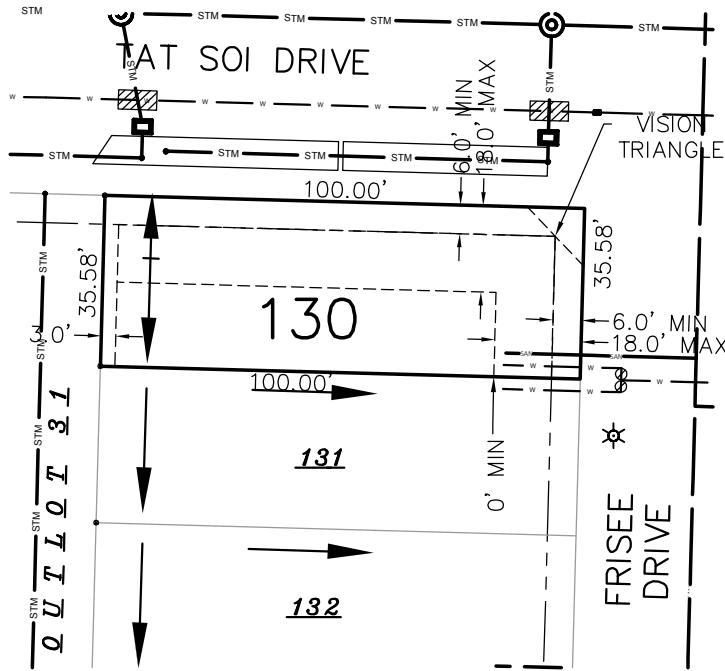

LEGEND

- SURFACE DRAINAGE SWALE DIRECTION
- BUILDING SETBACK LINE
- WATER SERVICE (PROPOSED)
- SANITARY LATERAL (PROPOSED)
- 6' ELECTRIC AND GAS LINES BELOW GRADE EASEMENT
- 10' UTILITY EASEMENT
- STREET LIGHT



TRANSECT ZONE: T4
 LOT SQUARE FOOTAGE: 3,558
 BLDG. ENV. WIDTH AT SETBACK: 29.6'

NOTE:
 AREAS DELINEATED AS VISION TRIANGLE AREAS
 SHALL HAVE NO PLANTINGS OVER TWO (2) FEET
 IN HEIGHT.

TYPICAL VISION CORNER DETAIL

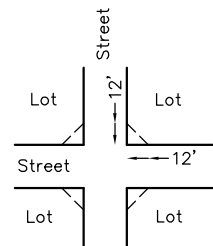

BSE1921\Final Plat\sales maps.dwg

LOT 130
 TERRAVESSA
 FITCHBURG LANDS, LLC

DATE: 04/16/2020 PROJECT NO.: BSE1921

SCALE: 1"=40'

IF THIS BAR DOES NOT MEASURE 1" THEN DRAWING IS NOT TO SCALE

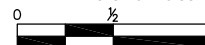

Burse
 surveying & engineering Inc.
 2801 International Lane, Suite 101
 Madison, WI 53704 608.250.9263
 Fax: 608.250.9266
 email: mburse@bse-inc.net
 www.bursesurveyengr.com

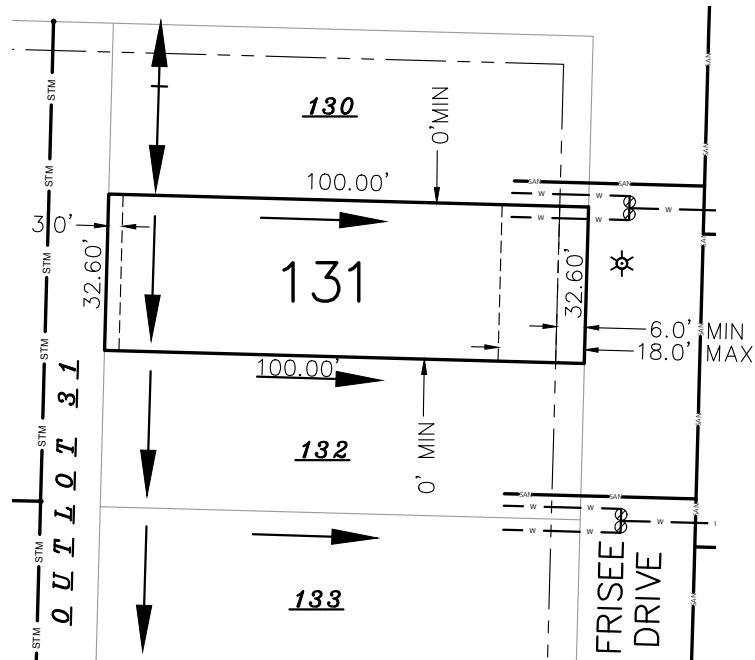

LEGEND

- SURFACE DRAINAGE SWALE DIRECTION
- BUILDING SETBACK LINE
- WATER SERVICE (PROPOSED)
- SANITARY LATERAL (PROPOSED)
- 6' ELECTRIC AND GAS LINES BELOW GRADE EASEMENT
- 10' UTILITY EASEMENT
- STREET LIGHT

TRANSECT ZONE: T4
 LOT SQUARE FOOTAGE: 3,260
 BLDG. ENV. WIDTH AT SETBACK: 32.6'

BSE1921\Final Plat\sales maps.dwg

LOT 131
 TERRAVESSA
 FITCHBURG LANDS, LLC

DATE 12-03-2018	PROJECT NO. BSE1921
SCALE 1" = 40'	
IF THIS BAR DOES NOT MEASURE 1" THEN DRAWING IS NOT TO SCALE	

Burse
 surveying & engineering LLC

2801 International Lane, Suite 101
 Madison, WI 53704 608.250.9263
 Fax: 608.250.9266
 email: mburse@bse-inc.net
 www.bursesurveyengr.com

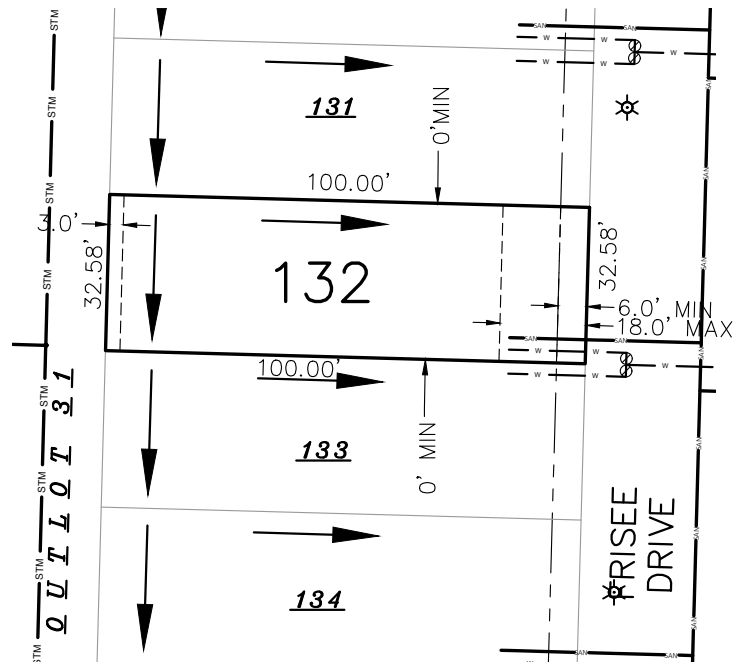

LEGEND

- SURFACE DRAINAGE SWALE DIRECTION
- BUILDING SETBACK LINE
- WATER SERVICE (PROPOSED)
- SANITARY LATERAL (PROPOSED)
- 6' ELECTRIC AND GAS LINES BELOW GRADE EASEMENT
- 10' UTILITY EASEMENT
- STREET LIGHT



TRANSECT ZONE: T4
 LOT SQUARE FOOTAGE: 3,258
 BLDG. ENV. WIDTH AT SETBACK: 32.6'

BSE1921\Final Plat\sales maps.dwg

LOT 132
 TERRAVESSA
 FITCHBURG LANDS, LLC

DATE 12-03-2018	PROJECT NO. BSE1921
SCALE 1" = 40'	
IF THIS BAR DOES NOT MEASURE 1" THEN DRAWING IS NOT TO SCALE	

Burse
 surveying & engineering LLC
 2801 International Lane, Suite 101
 Madison, WI 53704 608.250.9263
 Fax: 608.250.9266
 email: mburse@bse-inc.net
 www.bursesurveyengr.com

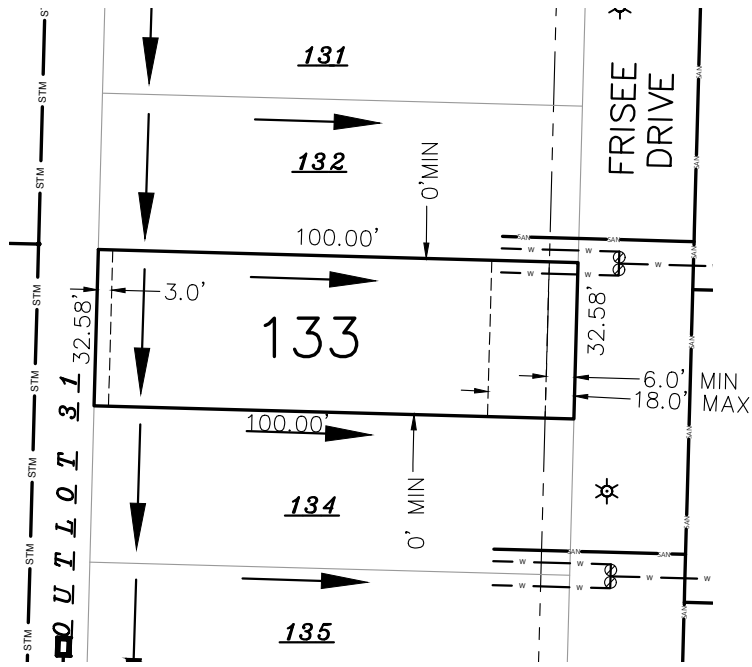

LEGEND

- SURFACE DRAINAGE SWALE DIRECTION
- BUILDING SETBACK LINE
- WATER SERVICE (PROPOSED)
- SANITARY LATERAL (PROPOSED)
- 6' ELECTRIC AND GAS LINES BELOW GRADE EASEMENT
- 10' UTILITY EASEMENT
- STREET LIGHT

TRANSECT ZONE: T4
 LOT SQUARE FOOTAGE: 3,258
 BLDG. ENV. WIDTH AT SETBACK: 32.6'

BSE1921\Final Plat\sales maps.dwg

LOT 133
 TERRAVESSA
 FITCHBURG LANDS, LLC

DATE 12-03-2018	PROJECT NO. BSE1921
SCALE 1" = 40'	
IF THIS BAR DOES NOT MEASURE 1" THEN DRAWING IS NOT TO SCALE	

Burse
 surveying & engineering LLC
 2801 International Lane, Suite 101
 Madison, WI 53704 608.250.9263
 Fax: 608.250.9266
 email: mburse@bse-inc.net
 www.bursesurveyengr.com

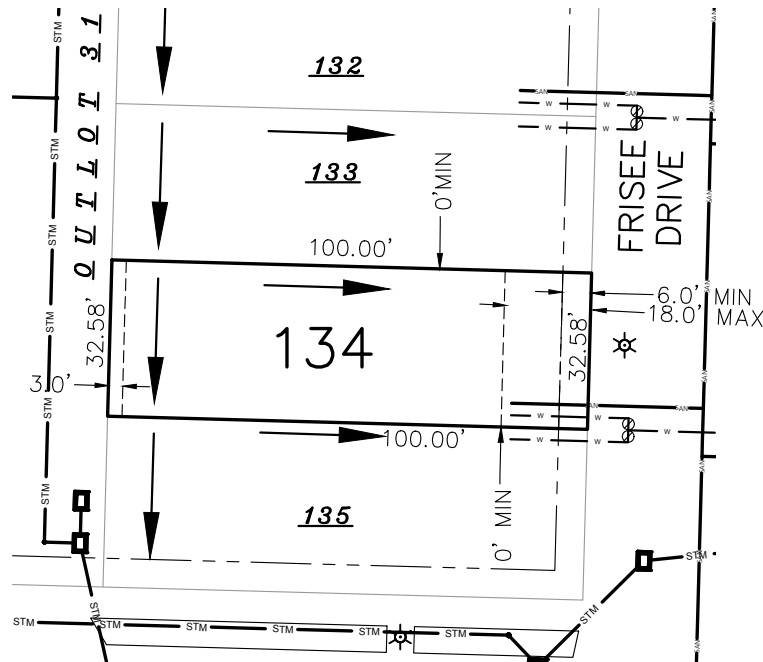

LEGEND

- SURFACE DRAINAGE SWALE DIRECTION
- BUILDING SETBACK LINE
- WATER SERVICE (PROPOSED)
- SANITARY LATERAL (PROPOSED)
- 6' ELECTRIC AND GAS LINES BELOW GRADE EASEMENT
- 10' UTILITY EASEMENT
- STREET LIGHT



TRANSECT ZONE: T4
 LOT SQUARE FOOTAGE: 3,258
 BLDG. ENV. WIDTH AT SETBACK: 32.6'

BSE1921\Final Plat\sales maps.dwg

LOT 134
 TERRAVESSA
 FITCHBURG LANDS, LLC

DATE 12-03-2018	PROJECT NO. BSE1921
SCALE 1" = 40'	
IF THIS BAR DOES NOT MEASURE 1" THEN DRAWING IS NOT TO SCALE	

Burse
 surveying & engineering LLC
 2801 International Lane, Suite 101
 Madison, WI 53704 608.250.9263
 Fax: 608.250.9266
 email: mburse@bse-inc.net
 www.bursesurveyengr.com

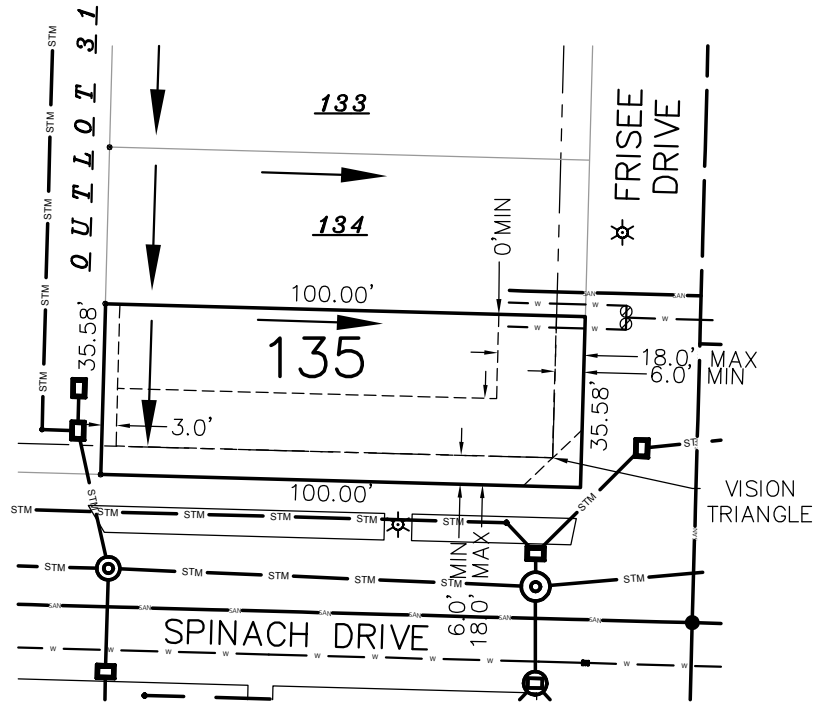

LEGEND

- SURFACE DRAINAGE SWALE DIRECTION
- BUILDING SETBACK LINE
- WATER SERVICE (PROPOSED)
- SANITARY LATERAL (PROPOSED)
- 6' ELECTRIC AND GAS LINES BELOW GRADE EASEMENT
- 10' UTILITY EASEMENT
- STREET LIGHT



TRANSECT ZONE: T4
 LOT SQUARE FOOTAGE: 3,558
 BLDG. ENV. WIDTH AT SETBACK: 29.6'

NOTE:
 AREAS DELINEATED AS VISION TRIANGLE AREAS
 SHALL HAVE NO PLANTINGS OVER TWO (2) FEET
 IN HEIGHT.

TYPICAL VISION CORNER DETAIL

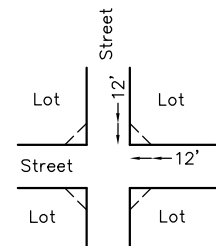

BSE1921\Final Plat\sales maps.dwg

LOT 135
 TERRAVESSA
 FITCHBURG LANDS, LLC

DATE: 04/16/2020 PROJECT NO.: BSE1921

SCALE: 1"=40'

IF THIS BAR DOES NOT MEASURE 1" THEN DRAWING IS NOT TO SCALE

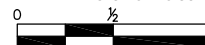

Burse
 surveying & engineering Inc.
 2801 International Lane, Suite 101
 Madison, WI 53704 608.250.9263
 Fax: 608.250.9266
 email: mburse@bse-inc.net
 www.bursesurveyengr.com

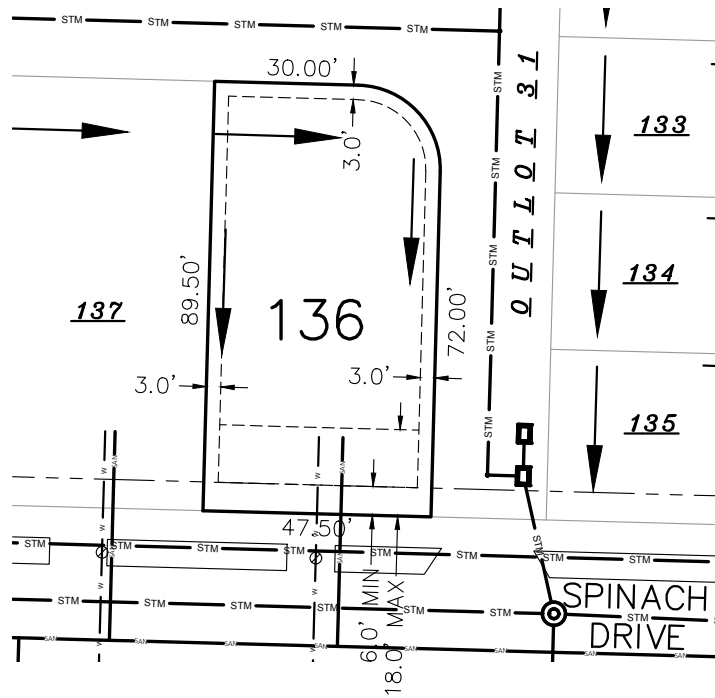

LEGEND

- SURFACE DRAINAGE SWALE DIRECTION
- BUILDING SETBACK LINE
- WATER SERVICE (PROPOSED)
- SANITARY LATERAL (PROPOSED)
- 6' ELECTRIC AND GAS LINES BELOW GRADE EASEMENT
- 10' UTILITY EASEMENT
- STREET LIGHT



TRANSECT ZONE: T4
 LOT SQUARE FOOTAGE: 4,186
 BLDG. ENV. WIDTH AT SETBACK: 41.50'

BSE1921\Final Plat\sales maps.dwg

LOT 136
 TERRAVESSA
 FITCHBURG LANDS, LLC

DATE 12-03-2018	PROJECT NO. BSE1921
SCALE 1" = 40'	
IF THIS BAR DOES NOT MEASURE 1" THEN DRAWING IS NOT TO SCALE	

Burse
 surveying & engineering LLC
 2801 International Lane, Suite 101
 Madison, WI 53704 608.250.9263
 Fax: 608.250.9266
 email: mburse@bse-inc.net
 www.bursesurveyengr.com

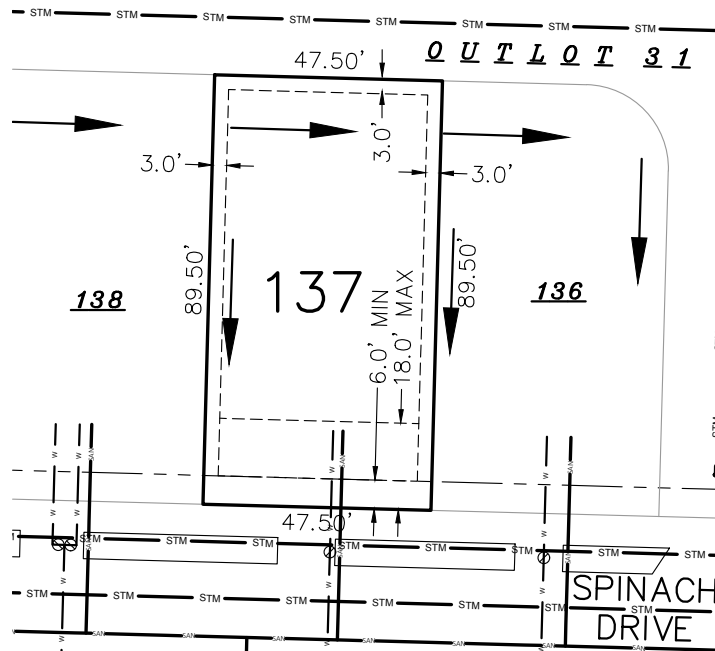

LEGEND

- SURFACE DRAINAGE SWALE DIRECTION
- BUILDING SETBACK LINE
- WATER SERVICE (PROPOSED)
- SANITARY LATERAL (PROPOSED)
- 6' ELECTRIC AND GAS LINES BELOW GRADE EASEMENT
- 10' UTILITY EASEMENT
- STREET LIGHT



TRANSECT ZONE: T4
 LOT SQUARE FOOTAGE: 4,251
 BLDG. ENV. WIDTH AT SETBACK: 41.50'

BSE1921\Final Plat\sales maps.dwg

LOT 137
 TERRAVESSA
 FITCHBURG LANDS, LLC

DATE 12-03-2018	PROJECT NO. BSE1921
SCALE 1" = 40'	
IF THIS BAR DOES NOT MEASURE 1" THEN DRAWING IS NOT TO SCALE	

Burse
 surveying & engineering LLC
 2801 International Lane, Suite 101
 Madison, WI 53704 608.250.9263
 Fax: 608.250.9266
 email: mburse@bse-inc.net
 www.bursesurveyengr.com

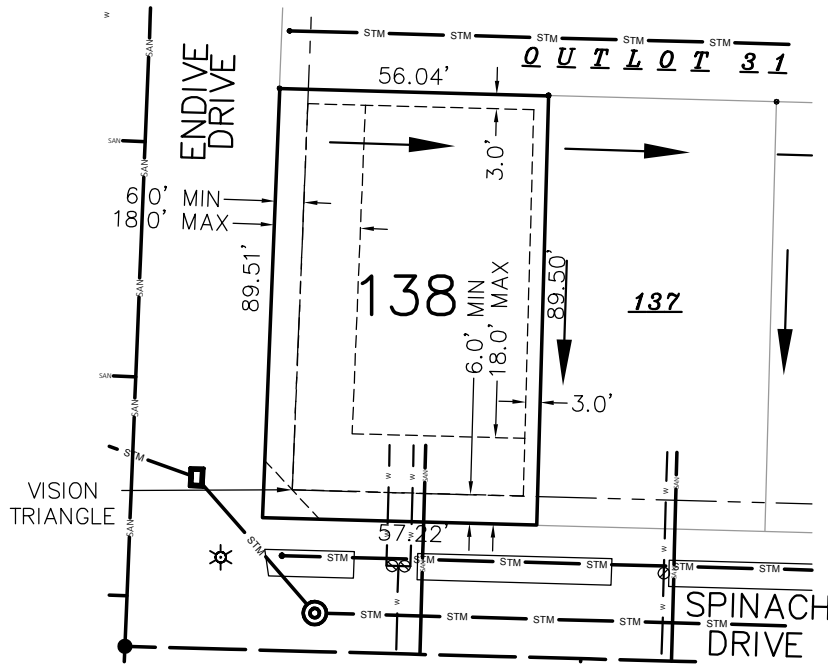

LEGEND

- SURFACE DRAINAGE SWALE DIRECTION
- BUILDING SETBACK LINE
- WATER SERVICE (PROPOSED)
- SANITARY LATERAL (PROPOSED)
- 6' ELECTRIC AND GAS LINES BELOW GRADE EASEMENT
- 10' UTILITY EASEMENT
- STREET LIGHT



TRANSECT ZONE: T4
 LOT SQUARE FOOTAGE: 5,069
 BLDG. ENV. WIDTH AT SETBACK: 48.22'

NOTE:
 AREAS DELINEATED AS VISION TRIANGLE AREAS
 SHALL HAVE NO PLANTINGS OVER TWO (2) FEET
 IN HEIGHT.

TYPICAL VISION CORNER DETAIL

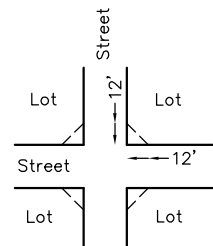

BSE1921\Final Plat\sales maps.dwg

LOT 138
 TERRAVESSA
 FITCHBURG LANDS, LLC

DATE: 04/16/2020 PROJECT NO.: BSE1921

SCALE: 1" = 40'

IF THIS BAR DOES NOT MEASURE 1" THEN DRAWING IS NOT TO SCALE

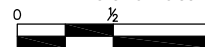

Burse
 surveying & engineering Inc.
 2801 International Lane, Suite 101
 Madison, WI 53704 608.250.9263
 Fax: 608.250.9266
 email: mburse@bse-inc.net
 www.bursesurveyengr.com

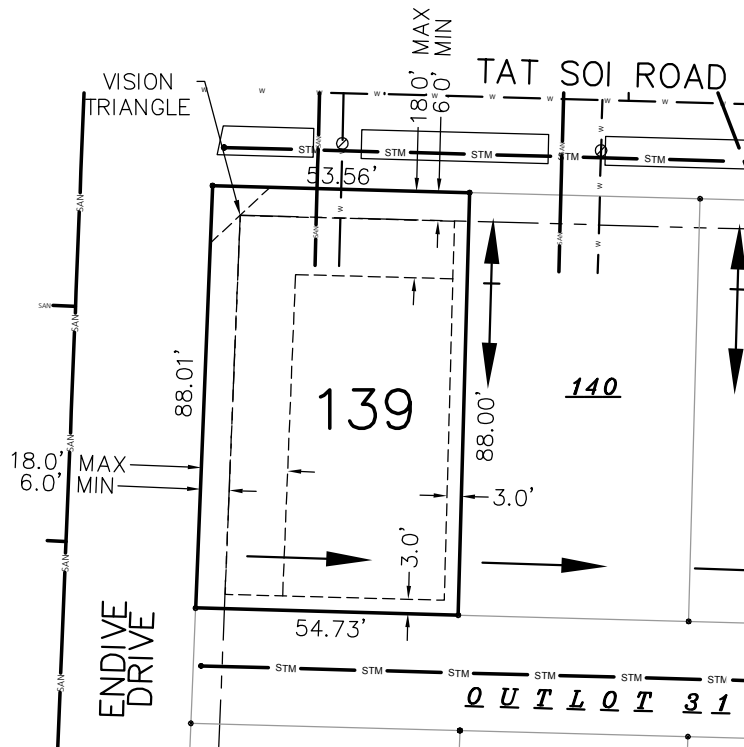

LEGEND

- SURFACE DRAINAGE SWALE DIRECTION
- BUILDING SETBACK LINE
- WATER SERVICE (PROPOSED)
- SANITARY LATERAL (PROPOSED)
- 6' ELECTRIC AND GAS LINES BELOW GRADE EASEMENT
- 10' UTILITY EASEMENT
- STREET LIGHT

TRANSECT ZONE: T4
 LOT SQUARE FOOTAGE: 4,765
 BLDG. ENV. WIDTH AT SETBACK: 44.56'

NOTE:
 AREAS DELINEATED AS VISION TRIANGLE AREAS
 SHALL HAVE NO PLANTINGS OVER TWO (2) FEET
 IN HEIGHT.

TYPICAL VISION CORNER DETAIL

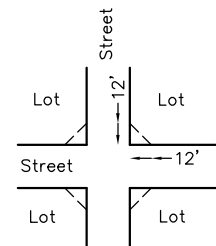

BSE1921\Final Plat\sales maps.dwg

LOT 139
 TERRAVESSA
 FITCHBURG LANDS, LLC

DATE: 04/16/2020 PROJECT NO.: BSE1921

SCALE: 1"=40'

IF THIS BAR DOES NOT MEASURE 1" THEN DRAWING IS NOT TO SCALE

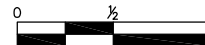

Burse
 surveying & engineering Inc.
 2801 International Lane, Suite 101
 Madison, WI 53704 608.250.9263
 Fax: 608.250.9266
 email: mburse@bse-inc.net
 www.bursesurveyengr.com

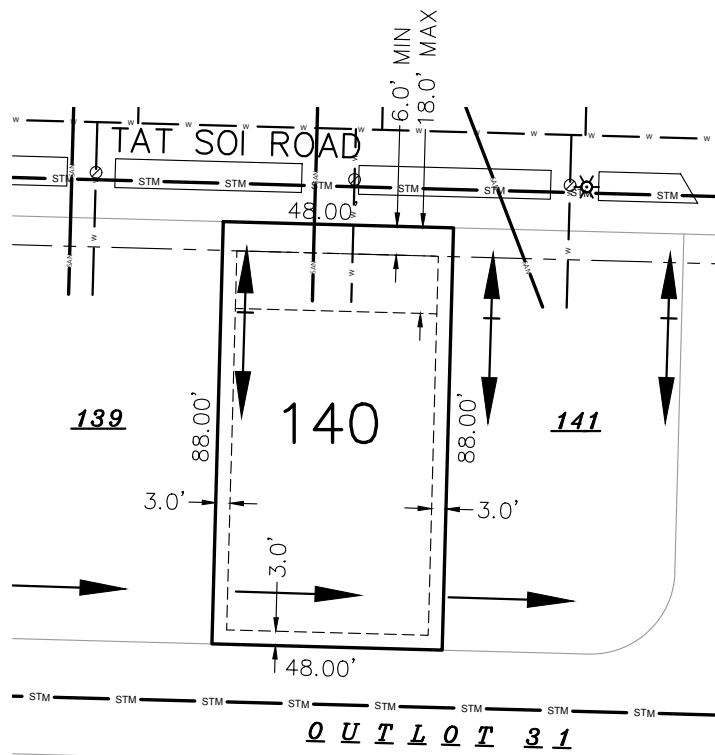

LEGEND

- SURFACE DRAINAGE SWALE DIRECTION
- BUILDING SETBACK LINE
- WATER SERVICE (PROPOSED)
- SANITARY LATERAL (PROPOSED)
- 6' ELECTRIC AND GAS LINES BELOW GRADE EASEMENT
- 10' UTILITY EASEMENT
- STREET LIGHT

TRANSECT ZONE: T4
 LOT SQUARE FOOTAGE: 4,224
 BLDG. ENV. WIDTH AT SETBACK: 42.00'

BSE1921\Final Plat\sales maps.dwg

LOT 140
 TERRAVESSA
 FITCHBURG LANDS, LLC

DATE 12-03-2018	PROJECT NO. BSE1921
SCALE 1" = 40'	
IF THIS BAR DOES NOT MEASURE 1" THEN DRAWING IS NOT TO SCALE	

Burse
 surveying & engineering LLC
 2801 International Lane, Suite 101
 Madison, WI 53704 G08.250.9263
 Fax: G08.250.9266
 email: mburse@bse-inc.net
 www.bursesurveyengr.com

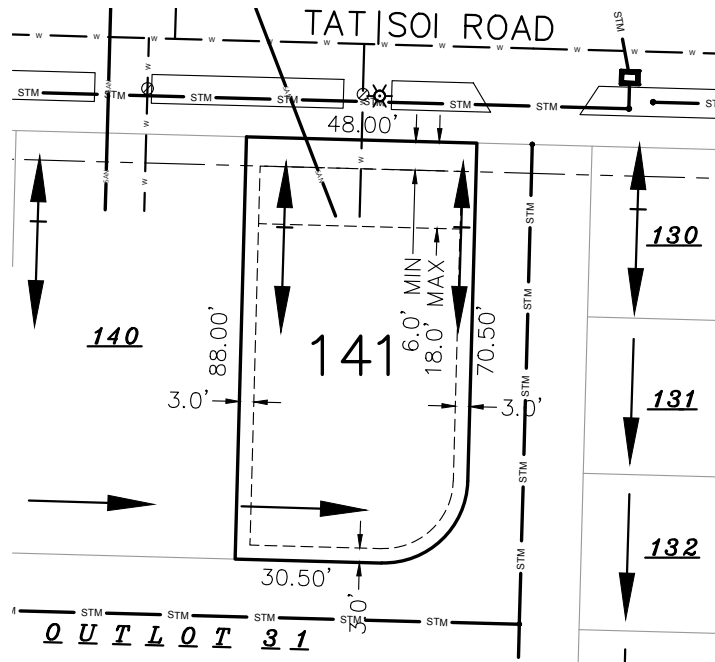

LEGEND

- SURFACE DRAINAGE SWALE DIRECTION
- BUILDING SETBACK LINE
- WATER SERVICE (PROPOSED)
- SANITARY LATERAL (PROPOSED)
- 6' ELECTRIC AND GAS LINES BELOW GRADE EASEMENT
- 10' UTILITY EASEMENT
- STREET LIGHT

TRANSECT ZONE: T4
 LOT SQUARE FOOTAGE: 4,158
 BLDG. ENV. WIDTH AT SETBACK: 42.00'

BSE1921\Final Plat\sales maps.dwg

LOT 141
 TERRAVESSA
 FITCHBURG LANDS, LLC

DATE 12-03-2018	PROJECT NO. BSE1921
SCALE 1" = 40'	
IF THIS BAR DOES NOT MEASURE 1" THEN DRAWING IS NOT TO SCALE	

Burse
 surveying & engineering ^{LLC}
 2801 International Lane, Suite 101
 Madison, WI 53704 608.250.9263
 Fax: 608.250.9266
 email: mburse@bse-inc.net
 www.bursesurveyengr.com

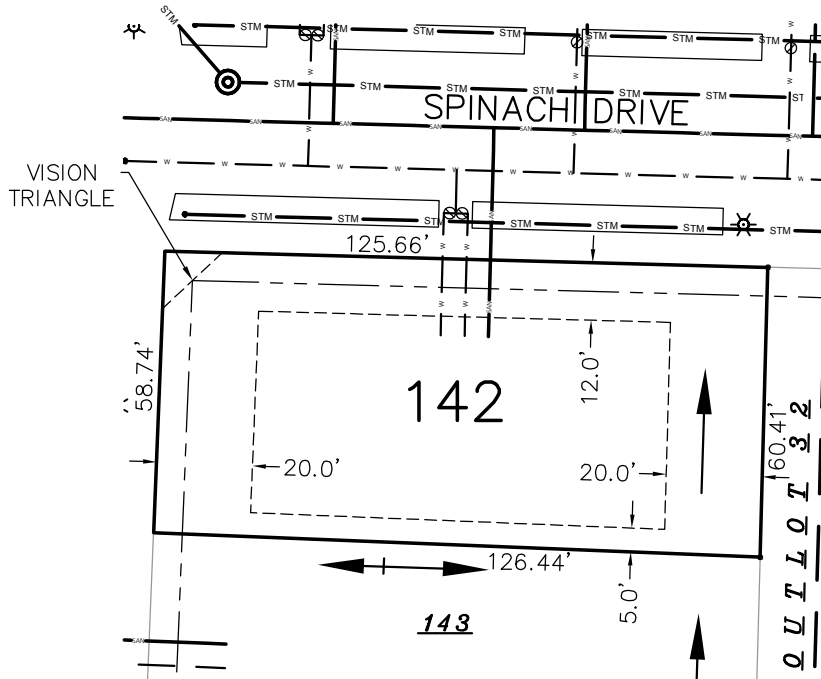

LEGEND

- SURFACE DRAINAGE SWALE DIRECTION
- BUILDING SETBACK LINE
- WATER SERVICE (PROPOSED)
- SANITARY LATERAL (PROPOSED)
- 6' ELECTRIC AND GAS LINES BELOW GRADE EASEMENT
- 10' UTILITY EASEMENT
- STREET LIGHT



TRANSECT ZONE: T4
 LOT SQUARE FOOTAGE: 7,509
 BLDG. ENV. WIDTH AT SETBACK: 33.74'

NOTE:
 AREAS DELINEATED AS VISION TRIANGLE AREAS
 SHALL HAVE NO PLANTINGS OVER TWO (2) FEET
 IN HEIGHT.

TYPICAL VISION CORNER DETAIL

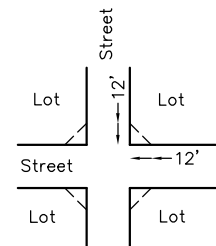

BSE1921\Final Plat\sales maps.dwg

LOT 142
 TERRAVESSA
 FITCHBURG LANDS, LLC

DATE: 04/16/2020 PROJECT NO.: BSE1921

SCALE
 1" = 40'

IF THIS BAR DOES NOT MEASURE 1"
 THEN DRAWING IS NOT TO SCALE

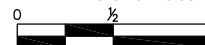

Burse
 surveying & engineering Inc.
 2801 International Lane, Suite 101
 Madison, WI 53704 608.250.9263
 Fax: 608.250.9266
 email: mburse@bse-inc.net
 www.bursesurveyengr.com

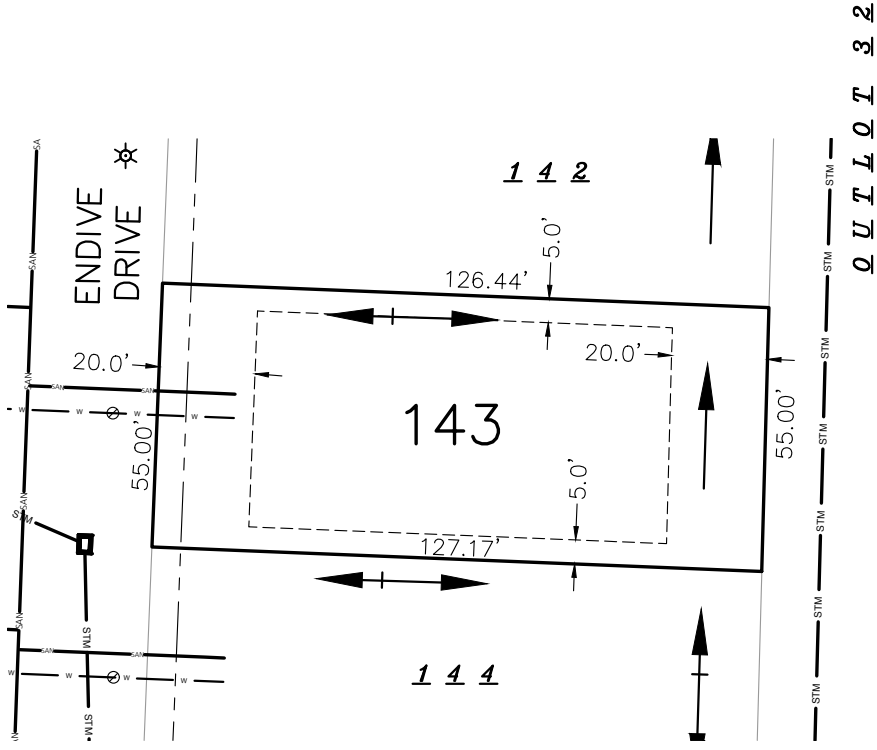

LEGEND

- SURFACE DRAINAGE SWALE DIRECTION
- BUILDING SETBACK LINE
- WATER SERVICE (PROPOSED)
- SANITARY LATERAL (PROPOSED)
- 6' ELECTRIC AND GAS LINES BELOW GRADE EASEMENT
- 10' UTILITY EASEMENT
- STREET LIGHT

TRANSECT ZONE: T3
 LOT SQUARE FOOTAGE: 6,974
 BLDG. ENV. WIDTH AT SETBACK: 45.0'

BSE1921\Final Plat\sales maps.dwg

LOT 143
 TERRAVESSA
 FITCHBURG LANDS, LLC

DATE 02-20-2018	PROJECT NO. BSE1921
SCALE 1" = 40'	
IF THIS BAR DOES NOT MEASURE 1" THEN DRAWING IS NOT TO SCALE	

Burse
 surveying & engineering ^{LLC}
 2801 International Lane, Suite 101
 Madison, WI 53704 608.250.9263
 Fax: 608.250.9266
 email: mburse@bse-inc.net
 www.bursesurveyengr.com

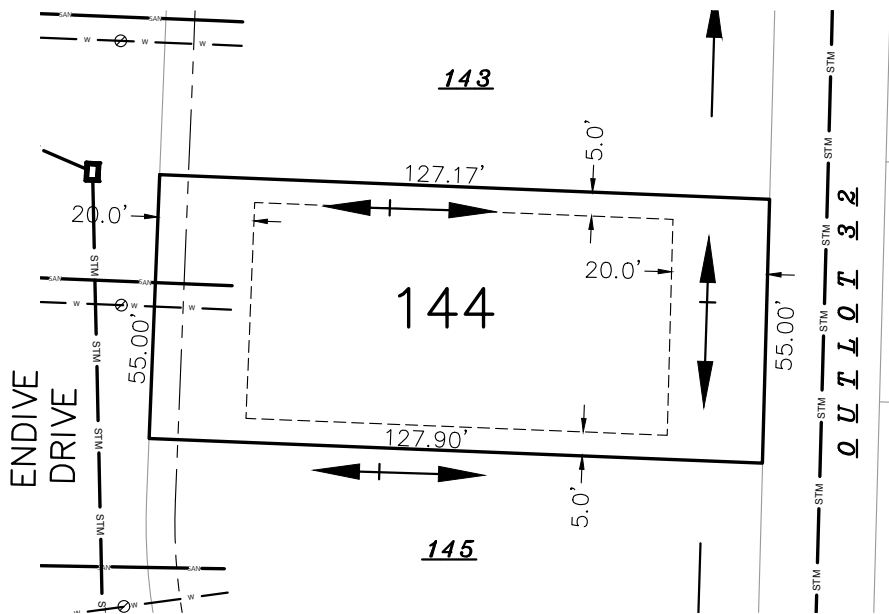

LEGEND

- SURFACE DRAINAGE SWALE DIRECTION
- BUILDING SETBACK LINE
- WATER SERVICE (PROPOSED)
- SANITARY LATERAL (PROPOSED)
- 6' ELECTRIC AND GAS LINES BELOW GRADE EASEMENT
- 10' UTILITY EASEMENT
- STREET LIGHT

TRANSECT ZONE: T3
 LOT SQUARE FOOTAGE: 7,014
 BLDG. ENV. WIDTH AT SETBACK: 45.0'

BSE1921\Final Plat\sales maps.dwg

LOT 144
 TERRAVESSA
 FITCHBURG LANDS, LLC

DATE 02-20-2018	PROJECT NO. BSE1921
SCALE 1" = 40'	
IF THIS BAR DOES NOT MEASURE 1" THEN DRAWING IS NOT TO SCALE	

Burse
 surveying & engineering LLC
 2801 International Lane, Suite 101
 Madison, WI 53704 608.250.9263
 Fax: 608.250.9266
 email: mburse@bse-inc.net
 www.bursesurveyengr.com

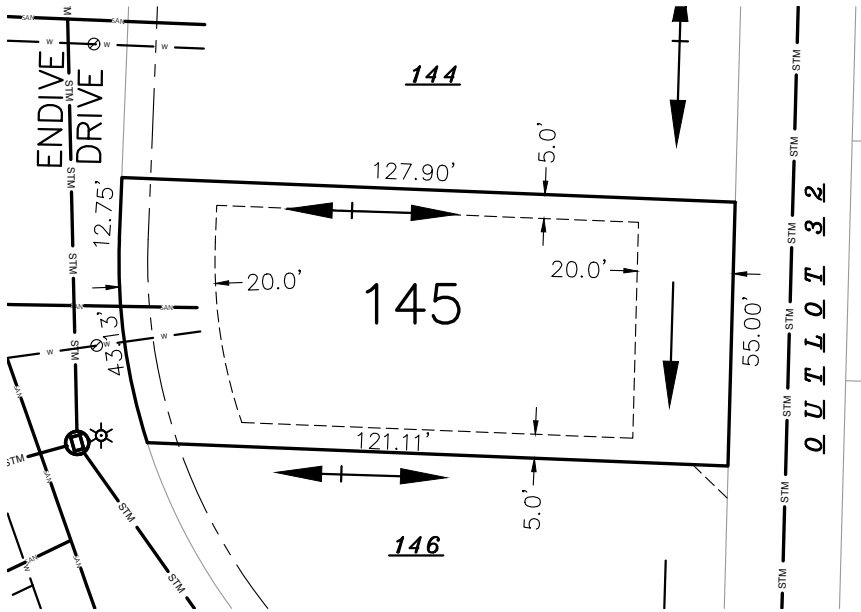

LEGEND

- SURFACE DRAINAGE SWALE DIRECTION
- BUILDING SETBACK LINE
- WATER SERVICE (PROPOSED)
- SANITARY LATERAL (PROPOSED)
- 6' ELECTRIC AND GAS LINES BELOW GRADE EASEMENT
- 10' UTILITY EASEMENT
- STREET LIGHT



TRANSECT ZONE: T3
 LOT SQUARE FOOTAGE: 6,950
 BLDG. ENV. WIDTH AT SETBACK: 45.00'

BSE1921\Final Plat\sales maps.dwg

LOT 145
 TERRAVESSA
 FITCHBURG LANDS, LLC

DATE 02-20-2018	PROJECT NO. BSE1921
SCALE 1" = 40'	
IF THIS BAR DOES NOT MEASURE 1" THEN DRAWING IS NOT TO SCALE	

Burse
 surveying & engineering LLC
 2801 International Lane, Suite 101
 Madison, WI 53704 608.250.9263
 Fax: 608.250.9266
 email: mburse@bse-inc.net
 www.bursesurveyengr.com

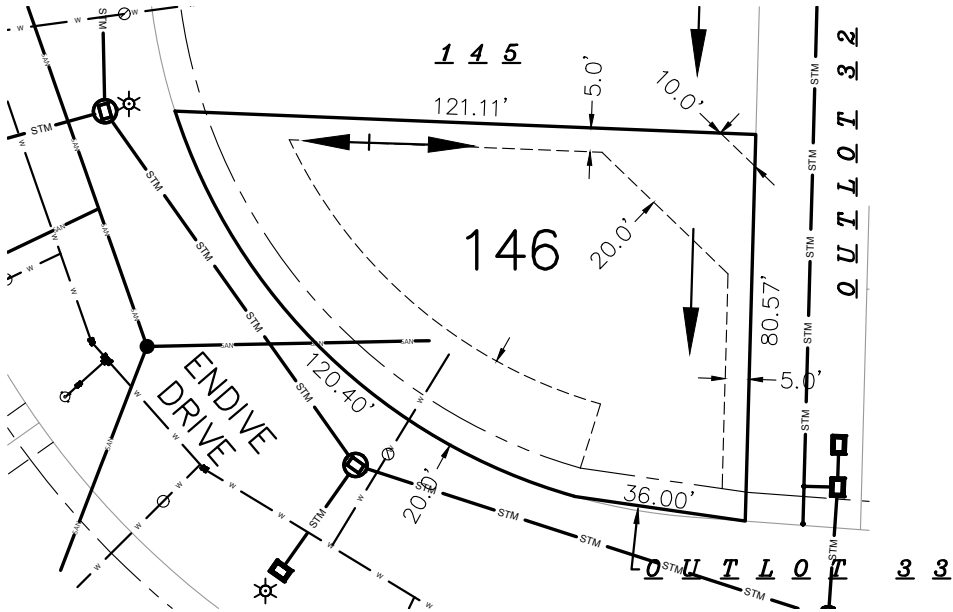

LEGEND

- SURFACE DRAINAGE SWALE DIRECTION
- BUILDING SETBACK LINE
- WATER SERVICE (PROPOSED)
- SANITARY LATERAL (PROPOSED)
- 6' ELECTRIC AND GAS LINES BELOW GRADE EASEMENT
- 10' UTILITY EASEMENT
- STREET LIGHT



TRANSECT ZONE: T3
 LOT SQUARE FOOTAGE: 7,226
 BLDG. ENV. WIDTH AT SETBACK:

BSE1921\Final Plat\sales maps.dwg

LOT 146
 TERRAVESSA
 FITCHBURG LANDS, LLC

DATE 02-20-2018	PROJECT NO. BSE1921
SCALE 1" = 40'	
IF THIS BAR DOES NOT MEASURE 1" THEN DRAWING IS NOT TO SCALE	

Burse
 surveying & engineering LLC
 2801 International Lane, Suite 101
 Madison, WI 53704 608.250.9263
 Fax: 608.250.9266
 email: mburse@bse-inc.net
 www.bursesurveyengr.com

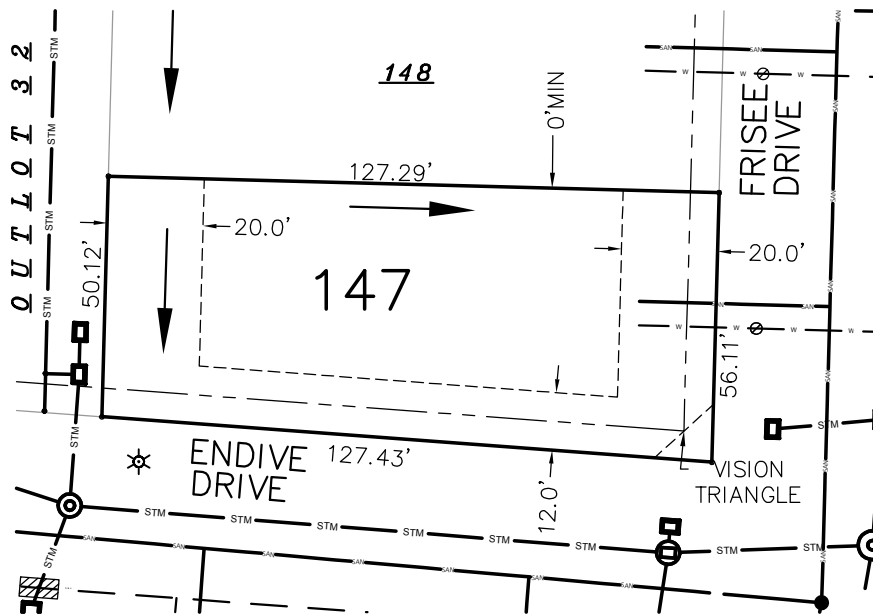

LEGEND

- SURFACE DRAINAGE SWALE DIRECTION
- BUILDING SETBACK LINE
- WATER SERVICE (PROPOSED)
- SANITARY LATERAL (PROPOSED)
- 6' ELECTRIC AND GAS LINES BELOW GRADE EASEMENT
- 10' UTILITY EASEMENT
- STREET LIGHT



TRANSECT ZONE: T3
 LOT SQUARE FOOTAGE: 6,761
 BLDG. ENV. WIDTH AT SETBACK: 43.2'

NOTE:
 AREAS DELINEATED AS VISION TRIANGLE AREAS
 SHALL HAVE NO PLANTINGS OVER TWO (2) FEET
 IN HEIGHT.

TYPICAL VISION CORNER DETAIL

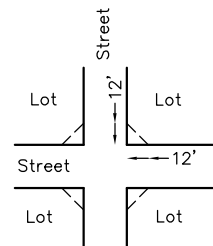

BSE1921\Final Plat\sales maps.dwg

LOT 147
 TERRAVESSA
 FITCHBURG LANDS, LLC

DATE: 04/16/2020 PROJECT NO.: BSE1921

SCALE: 1"=40'

IF THIS BAR DOES NOT MEASURE 1" THEN DRAWING IS NOT TO SCALE

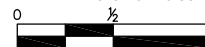

Burse
 surveying & engineering Inc.
 2801 International Lane, Suite 101
 Madison, WI 53704 608.250.9263
 Fax: 608.250.9266
 email: mburse@bse-inc.net
 www.bursesurveyengr.com

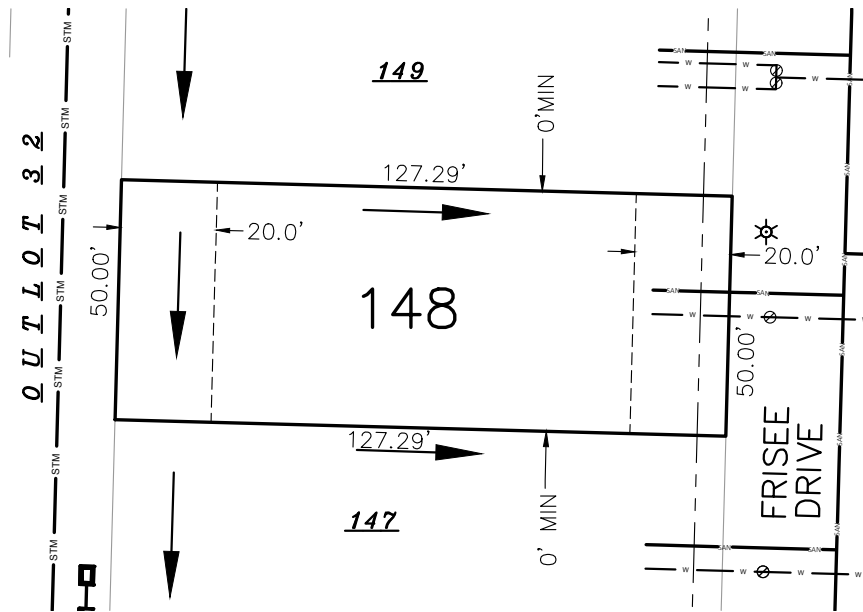

LEGEND

- SURFACE DRAINAGE SWALE DIRECTION
- BUILDING SETBACK LINE
- WATER SERVICE (PROPOSED)
- SANITARY LATERAL (PROPOSED)
- 6' ELECTRIC AND GAS LINES BELOW GRADE EASEMENT
- 10' UTILITY EASEMENT
- STREET LIGHT

TRANSECT ZONE: T3
 LOT SQUARE FOOTAGE: 6,365
 BLDG. ENV. WIDTH AT SETBACK: 50.0'

BSE1921\Final Plat\sales maps.dwg

LOT 148
 TERRAVESSA
 FITCHBURG LANDS, LLC

DATE 02-20-2018	PROJECT NO. BSE1921
SCALE 1" = 40'	
IF THIS BAR DOES NOT MEASURE 1" THEN DRAWING IS NOT TO SCALE	

Burse
 surveying & engineering ^{LLC}
 2801 International Lane, Suite 101
 Madison, WI 53704 608.250.9263
 Fax: 608.250.9266
 email: mburse@bse-inc.net
 www.bursesurveyengr.com

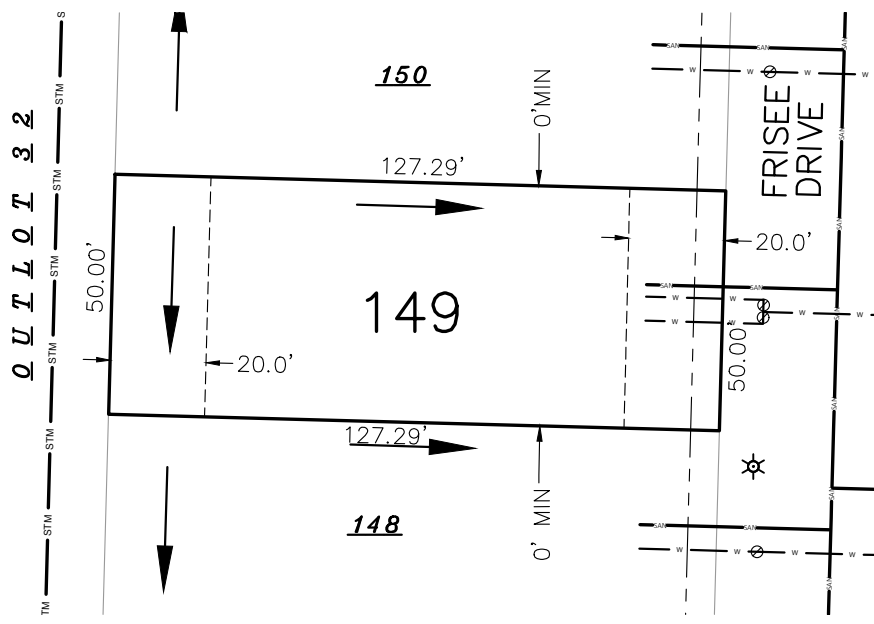

LEGEND

- SURFACE DRAINAGE SWALE DIRECTION
- BUILDING SETBACK LINE
- WATER SERVICE (PROPOSED)
- SANITARY LATERAL (PROPOSED)
- 6' ELECTRIC AND GAS LINES BELOW GRADE EASEMENT
- 10' UTILITY EASEMENT
- STREET LIGHT

TRANSECT ZONE: T3
 LOT SQUARE FOOTAGE: 6,365
 BLDG. ENV. WIDTH AT SETBACK: 50.0'

BSE1921\Final Plat\sales maps.dwg

LOT 149
 TERRAVESSA
 FITCHBURG LANDS, LLC

DATE 02-20-2018	PROJECT NO. BSE1921
SCALE 1" = 40'	
IF THIS BAR DOES NOT MEASURE 1" THEN DRAWING IS NOT TO SCALE	

Burse
 surveying & engineering ^{LLC}
 2801 International Lane, Suite 101
 Madison, WI 53704 608.250.9263
 Fax: 608.250.9266
 email: mburse@bse-inc.net
 www.bursesurveyengr.com

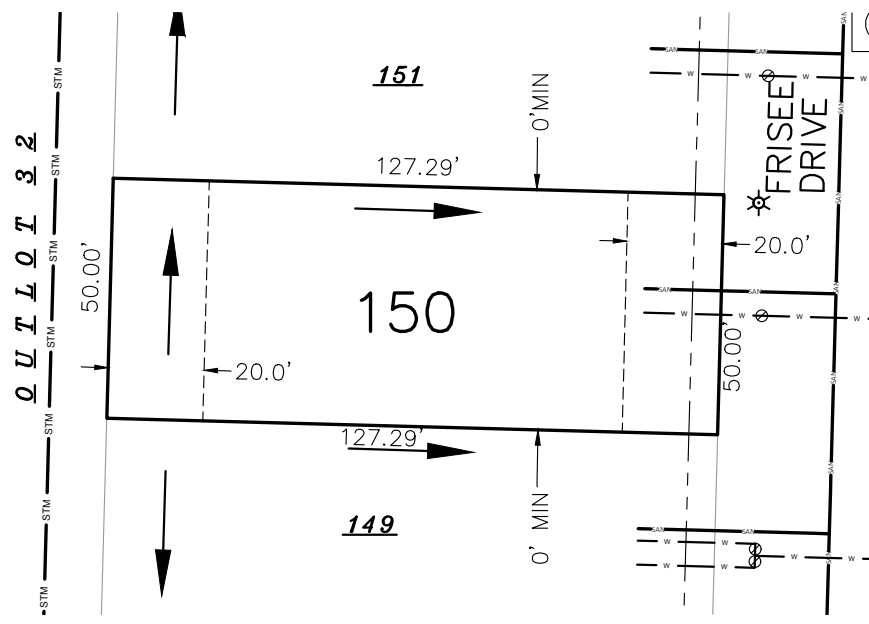

LEGEND

- SURFACE DRAINAGE SWALE DIRECTION
- BUILDING SETBACK LINE
- WATER SERVICE (PROPOSED)
- SANITARY LATERAL (PROPOSED)
- 6' ELECTRIC AND GAS LINES BELOW GRADE EASEMENT
- 10' UTILITY EASEMENT
- STREET LIGHT

TRANSECT ZONE: T3
 LOT SQUARE FOOTAGE: 6,365
 BLDG. ENV. WIDTH AT SETBACK: 50.0'

BSE1921\Final Plat\sales maps.dwg

LOT 150
 TERRAVESSA
 FITCHBURG LANDS, LLC

DATE 02-20-2018	PROJECT NO. BSE1921
SCALE 1" = 40'	
IF THIS BAR DOES NOT MEASURE 1" THEN DRAWING IS NOT TO SCALE	

Burse
 surveying & engineering ^{LLC}
 2801 International Lane, Suite 101
 Madison, WI 53704 G08.250.9263
 Fax: G08.250.9266
 email: mburse@bse-inc.net
 www.bursesurveyengr.com

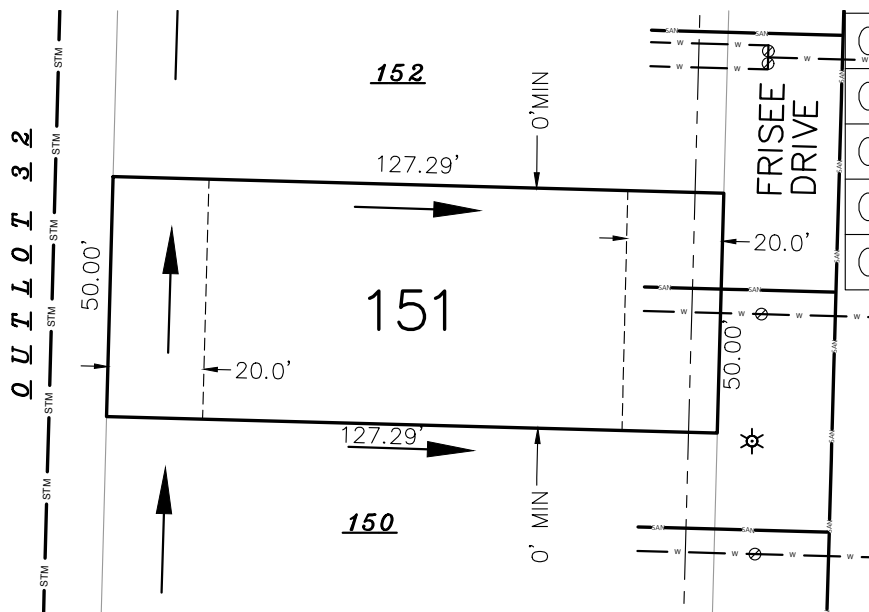

LEGEND

- SURFACE DRAINAGE SWALE DIRECTION
- BUILDING SETBACK LINE
- WATER SERVICE (PROPOSED)
- SANITARY LATERAL (PROPOSED)
- 6' ELECTRIC AND GAS LINES BELOW GRADE EASEMENT
- 10' UTILITY EASEMENT
- STREET LIGHT



TRANSECT ZONE: T3
 LOT SQUARE FOOTAGE: 6,365
 BLDG. ENV. WIDTH AT SETBACK: 50.0'

LOT 151
 TERRAVESSA
 FITCHBURG LANDS, LLC

DATE 02-20-2018	PROJECT NO. BSE1921
SCALE 1" = 40'	
IF THIS BAR DOES NOT MEASURE 1" THEN DRAWING IS NOT TO SCALE	

Burse
 surveying & engineering ^{LLC}
 2801 International Lane, Suite 101
 Madison, WI 53704 608.250.9263
 Fax: 608.250.9266
 email: mburse@bse-inc.net
 www.bursesurveyengr.com

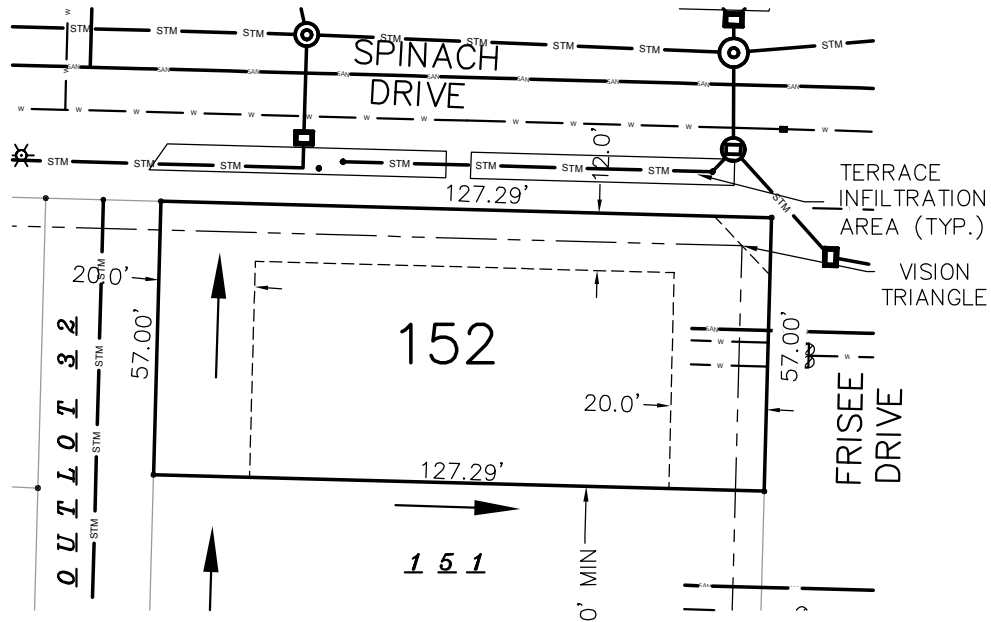

LEGEND

- SURFACE DRAINAGE SWALE DIRECTION
- BUILDING SETBACK LINE
- WATER SERVICE (PROPOSED)
- SANITARY LATERAL (PROPOSED)
- 6' ELECTRIC AND GAS LINES BELOW GRADE EASEMENT
- 10' UTILITY EASEMENT
- STREET LIGHT



TRANSECT ZONE: T3
 LOT SQUARE FOOTAGE: 7,256
 BLDG. ENV. WIDTH AT SETBACK: 45.0'

NOTE:
 AREAS DELINEATED AS VISION TRIANGLE AREAS
 SHALL HAVE NO PLANTINGS OVER TWO (2) FEET
 IN HEIGHT.

TYPICAL VISION CORNER DETAIL

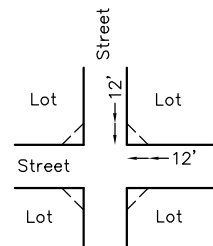

BSE1921\Final Plat\sales maps.dwg

LOT 152
 TERRAVESSA
 FITCHBURG LANDS, LLC

DATE: 04/16/2020
 PROJECT NO.: BSE1921

SCALE: 1"=40'

IF THIS BAR DOES NOT MEASURE 1" THEN DRAWING IS NOT TO SCALE

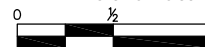

Burse
 surveying & engineering Inc.
 2801 International Lane, Suite 101
 Madison, WI 53704 608.250.9263
 Fax: 608.250.9266
 email: mburse@bse-inc.net
 www.bursesurveyengr.com

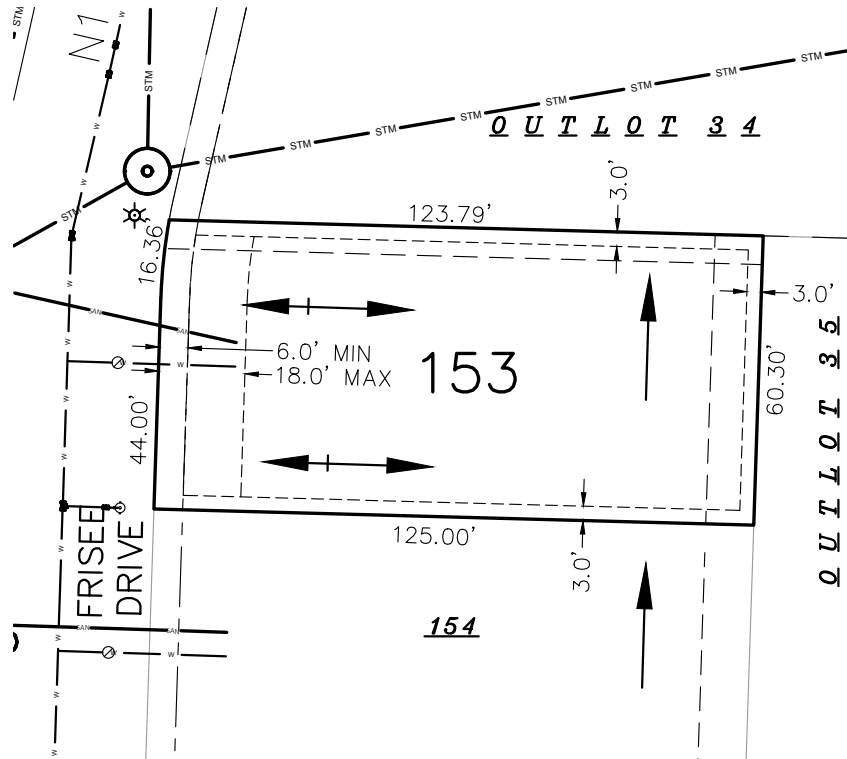

LEGEND

- SURFACE DRAINAGE SWALE DIRECTION
- BUILDING SETBACK LINE
- WATER SERVICE (PROPOSED)
- SANITARY LATERAL (PROPOSED)
- 6' ELECTRIC AND GAS LINES BELOW GRADE EASEMENT
- 10' UTILITY EASEMENT
- STREET LIGHT

TRANSECT ZONE: T4
 LOT SQUARE FOOTAGE: 7,530
 BLDG. ENV. WIDTH AT SETBACK: 54.3'

BSE1921\Final Plat\sales maps.dwg

LOT 153
 TERRAVESSA
 FITCHBURG LANDS, LLC

DATE 02-20-2018	PROJECT NO. BSE1921
SCALE 1" = 40'	
IF THIS BAR DOES NOT MEASURE 1" THEN DRAWING IS NOT TO SCALE	

Burse
 surveying & engineering LLC
 2801 International Lane, Suite 101
 Madison, WI 53704 608.250.9263
 Fax: 608.250.9266
 email: mburse@bse-inc.net
 www.bursesurveyengr.com

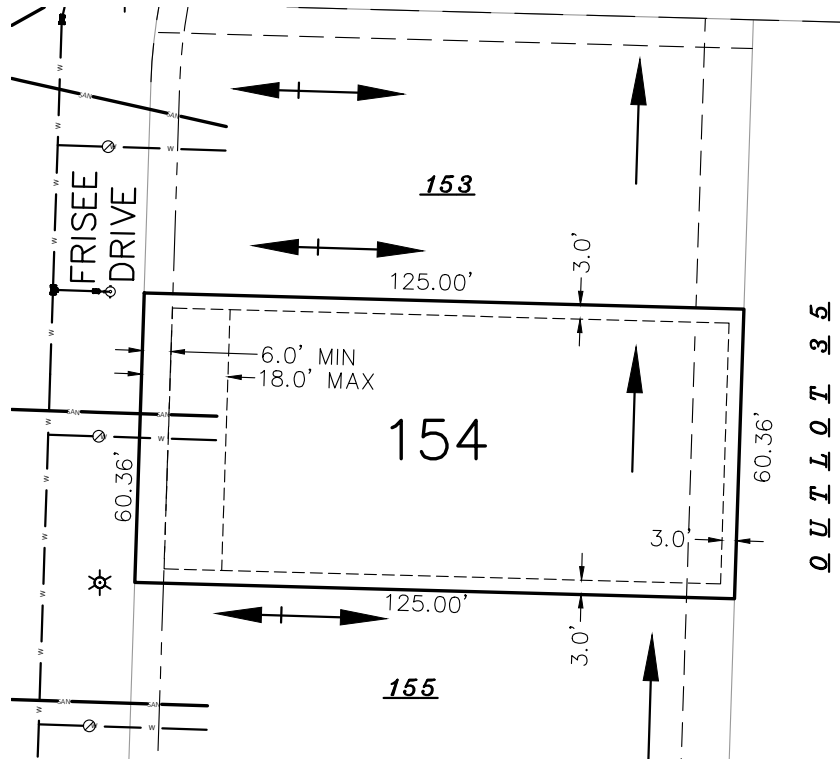

0 U T L O T 1 5 4

LEGEND	
	SURFACE DRAINAGE SWALE DIRECTION
	BUILDING SETBACK LINE
	WATER SERVICE (PROPOSED)
	SANITARY LATERAL (PROPOSED)
	6' ELECTRIC AND GAS LINES BELOW GRADE EASEMENT
	10' UTILITY EASEMENT
	STREET LIGHT



TRANSECT ZONE: T4
 LOT SQUARE FOOTAGE: 7,545
 BLDG. ENV. WIDTH AT SETBACK: 54.4'

BSE1921\Final Plat\sales maps.dwg

LOT 154
 TERRAVESSA
 FITCHBURG LANDS, LLC

DATE 02-20-2018	PROJECT NO. BSE1921
SCALE 1" = 40'	
IF THIS BAR DOES NOT MEASURE 1" THEN DRAWING IS NOT TO SCALE	

Burse
 surveying & engineering ^{LLC}
 2801 International Lane, Suite 101
 Madison, WI 53704 608.250.9263
 Fax: 608.250.9266
 email: mburse@bse-inc.net
 www.bursesurveyengr.com

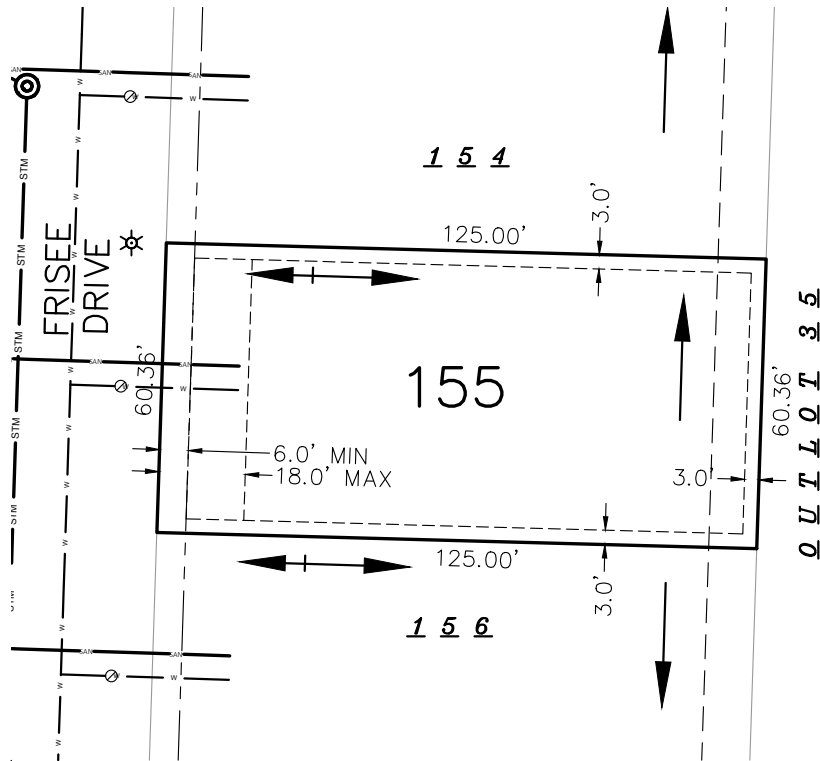

LEGEND

- SURFACE DRAINAGE SWALE DIRECTION
- BUILDING SETBACK LINE
- WATER SERVICE (PROPOSED)
- SANITARY LATERAL (PROPOSED)
- 6' ELECTRIC AND GAS LINES BELOW GRADE EASEMENT
- 10' UTILITY EASEMENT
- STREET LIGHT

TRANSECT ZONE: T4
 LOT SQUARE FOOTAGE: 7,545
 BLDG. ENV. WIDTH AT SETBACK: 54.4'

BSE1921\Final Plat\sales maps.dwg





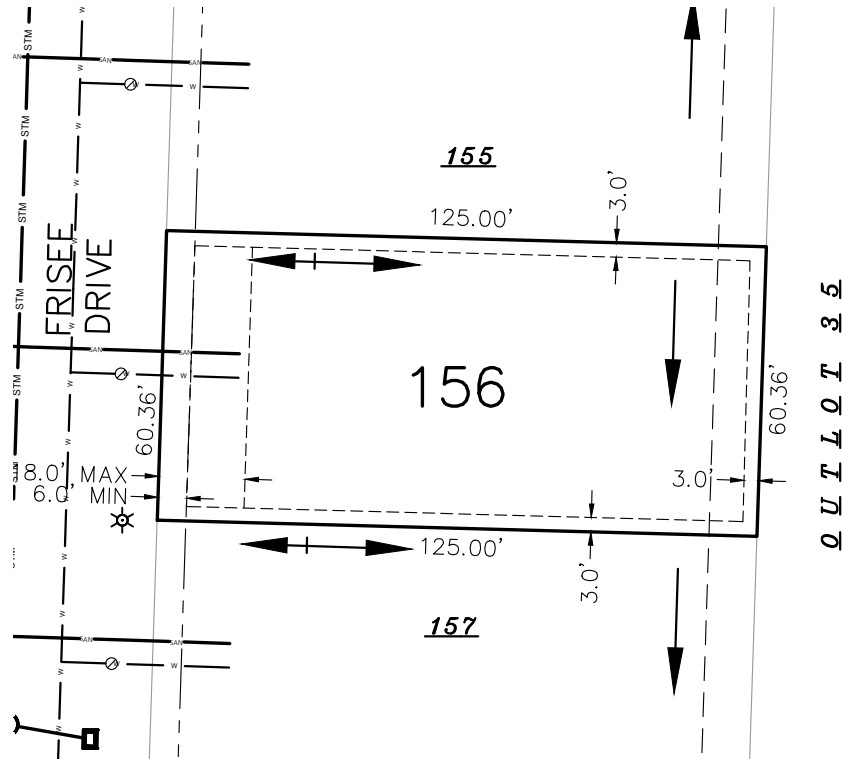

LOT 155
 TERRAVESSA
 FITCHBURG LANDS, LLC

DATE 02-20-2018	PROJECT NO. BSE1921
SCALE 1" = 40'	
IF THIS BAR DOES NOT MEASURE 1" THEN DRAWING IS NOT TO SCALE	

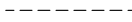
Burse
 surveying & engineering ^{LLC}
 2801 International Lane, Suite 101
 Madison, WI 53704 608.250.9263
 Fax: 608.250.9266
 email: mburse@bse-inc.net
 www.bursesurveyengr.com

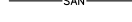

LEGEND

-  SURFACE DRAINAGE SWALE DIRECTION
-  BUILDING SETBACK LINE
-  WATER SERVICE (PROPOSED)
-  SANITARY LATERAL (PROPOSED)
-  6' ELECTRIC AND GAS LINES BELOW GRADE EASEMENT
-  10' UTILITY EASEMENT
-  STREET LIGHT

TRANSECT ZONE: T4
 LOT SQUARE FOOTAGE: 7,545
 BLDG. ENV. WIDTH AT SETBACK: 54.4'

BSE1921\Final Plat\sales maps.dwg

LOT 156
 TERRAVESSA
 FITCHBURG LANDS, LLC

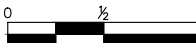
DATE 12-03-2018	PROJECT NO. BSE1921
SCALE 1" = 40'	
IF THIS BAR DOES NOT MEASURE 1" THEN DRAWING IS NOT TO SCALE	
	

Burse
 surveying & engineering ^{LLC}
 2801 International Lane, Suite 101
 Madison, WI 53704 608.250.9263
 Fax: 608.250.9266
 email: mburse@bse-inc.net
 www.bursesurveyengr.com

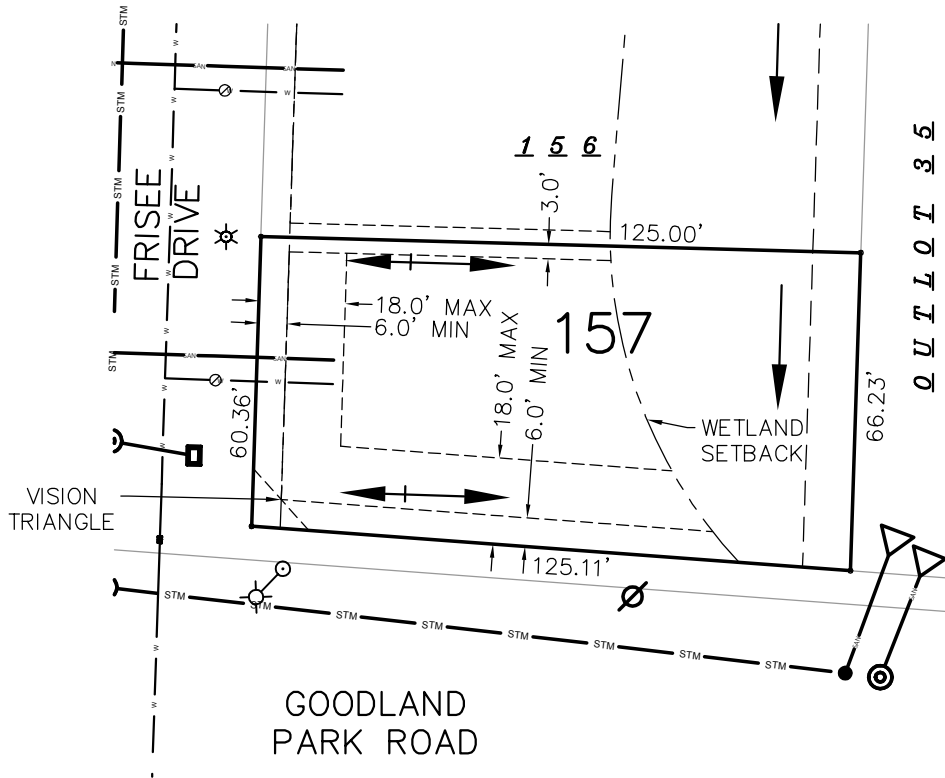

LEGEND

- SURFACE DRAINAGE SWALE DIRECTION
- BUILDING SETBACK LINE
- WATER SERVICE (PROPOSED)
- SANITARY LATERAL (PROPOSED)
- 6' ELECTRIC AND GAS LINES BELOW GRADE EASEMENT
- 10' UTILITY EASEMENT
- STREET LIGHT



TRANSECT ZONE: T4
 LOT SQUARE FOOTAGE: 7,912 BLDG.
 ENV. WIDTH AT SETBACK: 51.6'

TYPICAL VISION CORNER DETAIL

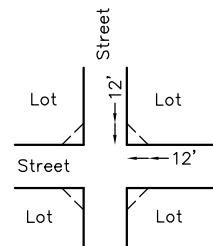

BSE1921\Final Plat\sales maps.dwg

LOT 157
 TERRAVESSA
 FITCHBURG LANDS, LLC

DATE: 04/16/2020 PROJECT NO.: BSE1921

SCALE
 1"=40'

IF THIS BAR DOES NOT MEASURE 1"
 THEN DRAWING IS NOT TO SCALE

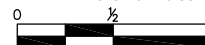

Burse
 surveying & engineering Inc.

2801 International Lane, Suite 101
 Madison, WI 53704 608.250.9263
 Fax: 608.250.9266
 email: mburse@bse-inc.net
 www.bursesurveyengr.com